

Datasheet s.84 EN331

Full port 1/4"-4" hot forged brass ball valves



Quality:

- 24h 100% seal test guaranteed
- Dual sealing system allows valve to be operated in either direction making installation easier
- No metal-to-metal moving parts
- No maintenance ever required
- Handle clearly shows ball position
- Silicone-free lubricant on all seals
- Travel stops on body to avoid stresses at stem
- Chrome plated brass ball for longer life with rinse hole

Body:

- Hot forged sand blasted external nickel plated brass body and cap sealed with Loctite® or equivalent thread sealant
- Finest brass according to EN 12165 and EN 12164 (formerly DIN 17660 and UNI 5705-65) specifications

Stem:

- Blowout-proof nickel plated brass stem
- Two FPM O-rings at the stem for maximum safety

Seals:

- Pure PTFE self-lubricating seats with flexible-lip design

PED Directives:

- Assessment according to Pressure Equipment Directive 97/23 CE module B+D by Pascal (1115)



Threads:

- EN 10226-1, ISO 228 parallel female by female threads

Flow:

- Full port to DIN 3357 for maximum flow

Handle:

- Geomet® carbon steel handle with thick PVC dip coating. Handle coating offers both thermal and electrical protection

Working Pressure and Working Temperature:

- 40 Bar (600 PSI) up to 2", 30 Bar (450 PSI) over 2"
- non-shock cold working pressure
- -40°C (-40°F) / +170°C (+350°F)
- For use with dangerous fluids temperature rating is -20°C +60°C and pressure rating is 5 bar
- AS4617 Limitation for GAS: 2100 Kpa up to 2" and 1500 Kpa from 2. 1/2" to 4" rated working pressure and 0°C / +60°C temperature
- Warning: freezing of the fluid in the installation may severely damage the valve

Options up to 2" size:

- Stem extension
- T-handle
- AISI 430 stainless steel handle
- Taper male by parallel female threads up to 4"
- Oval lockable handle up to 2", round over 2"
- Patented locking device for valves up to 4"

Upon Request:

- AISI 316 stainless steel ball
- Glass filled PTFE seals
- Custom Design

Approved by or in compliance with:

- The Australian Gas Association (Australia)
- Factory Mutual (United States)
- SVGW (Swiss)
- Water Regulations Advisory Scheme (United Kingdom)
- GOST-R (Russia)
- Hygiene and epidemic center in Moscow city (Russia)
- UkrSepro (Ukraine)

- BSI Group
- RoHS Compliant
- DIN-DVGW (Deutschland)
- EAC - Declaration of conformity (Russia-Kazakhstan-Belarus)

NOTE: Approvals apply to specific configurations/sizes only.

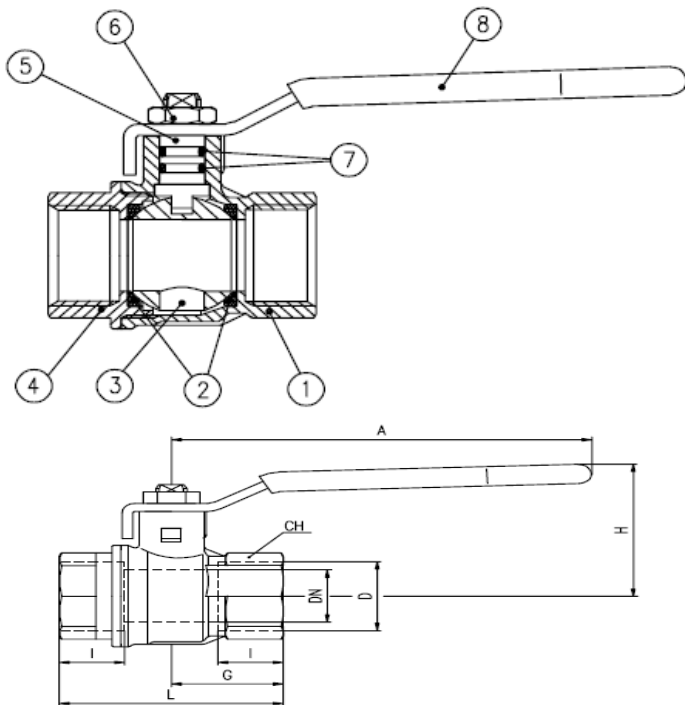

PART DESCRIPTION	Q.TY	MATERIAL
1 Nickel plated body (external nickel plated, unplated inside up to 2")	1	CW617N
2 Seat	2	PTFE
3 Chrome plated ball with rinse hole (the rinse hole is expected from 3/4" up to 2" sizes)	1	CW617N
4 Nickel plated end cap (external nickel plated, unplated inside up to 2")	1	CW617N
5 Nickel plated stem O-ring design	1	CW617N
6 Geomet® nut	1	CB4FF
7 O-Ring	2	FPM
8 Yellow PVC coated Geomet® steel handle	1	DD11

Code	S84B00	S84C00	S84D00	S84E00	S84F00	S84G00	S84H00	S84J00	S84L00	S84M00	S84N00
D (Inch)	1/4	3/8	1/2	3/4	1	1 1/4	1 1/2	2	2 1/2	3	4
DN (mm.)	8	10	15	20	25	32	40	50	65	80	100
I (mm.)	12	12	15,5	17	21	23	23	26,5	32	35	41,5
L (mm.)	45	45	59	64	81	93	102	121	156	177	216
G (mm.)	22,5	22,5	29,5	32	40,5	46,5	51	60,5	78	88,5	108
A (mm.)	82	82	100	120	120	158	158	158	255	255	255
H (mm.)	38	38	43	50	54	73	79	86	132	140	154
CH (mm.)	20	20	25	31	40	49	54	68,5	85	99	125

DN shows the nominal flow diameter. Actual flow diameter complies with full port DIN 3357 part 4. Stem configuration of valves over 2" is slightly different.

Pressure-Temperature Chart

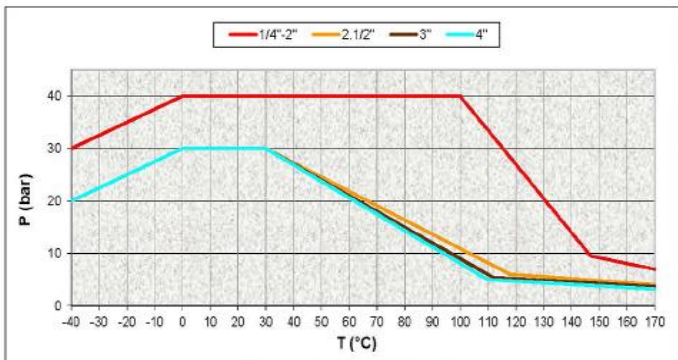

AS4617 Limitations for GAS: 2100 Kpa up to 2" and 1500 Kpa from 2. 1/2" to 4" rated working pressure and 0°C +60°C temperature

Pressure Drop Chart

