



ENGLISH

Datasheet

RS PRO CalRo Drinking Water Filter Kit

Specification

MODEL:
CALRO



Tool Kit:

Drill
Adjustable spanner
6mm or $\frac{1}{4}$ " Drill bit

Screwdriver
Plastic pipe cutter
14 & 19mm Spanners

Tape measure
12mm or $\frac{1}{2}$ " Drill bit

Fitting Instructions

1. Turn off water mains before installation.
2. Position self cutting tap on clean section of 15mm copper cold water supply. Loosely clamp to pipe with 2 screws on saddle making sure the rubber seal on the cutting head is seated correctly on pipe.
3. Turn main body of self cutting tap until copper pipe has been pierced. Tighten the 2 saddle screws and locking nut on the $\frac{3}{4}$ " screw on female x $\frac{1}{4}$ " pushfit adaptor.
4. Detach pipe from cap on membrane housing and unscrew cap. Insert membrane with the small end with 2 'o' rings first. Replace cap and pipe.
5. Position RO unit in a suitable position and secure. Make sure that there is enough room under the housings to unscrew them to replace cartridges
6. Fit $\frac{1}{4}$ " pipe to self cutting tap adaptor and to inlet on the RO unit housing. NOTE: All pipework supplied in this kit is $\frac{1}{4}$ " and can be cut to size. Use tube inserts on all connections.
7. Fit $\frac{1}{4}$ " pipe to the waste valve situated behind the membrane housing. Clamp the drain saddle to a suitable waste pipe and drill a 6mm/ $\frac{1}{4}$ " hole through the waste pipe using the saddle outlet as a guide. Screw nut on drain saddle, push in $\frac{1}{4}$ " pipe and tighten.
8. Position the RO storage tank and connect shut off valve making sure the tap is in the open position.
9. Using the $\frac{1}{4}$ " pipe, connect the storage valve to the 'T' connector on the slim cartridge (top cartridge).
10. Select a suitable position for the drinking tap on worktop. Drill a 12mm or $\frac{1}{2}$ " hole through worktop and mount as Fig 1. NOTE: Some worktops will need to be counter bored on the underside to recess the locating washer in order to have enough clearance to fit the compression nut.
11. Fit tube insert in $\frac{1}{4}$ " pipe. Push nut onto pipe and then plastic olive. Push pipe onto bottom of tap and seal using nut and olive. Attach the other end of the pipe to the single fitting on the slim cartridge (opposite the T fitting).
12. Check all connections are tight.
13. Turn on mains water supply and self cutting tap.
14. Check for leaks.
15. Depress touch tap and remove all locks. Water will run to drain from unit. This is normal. When water stops running to drain then the tank is full. The storage tank can take up to 10 hours to fill. Do not use the first tank of water. Allow the tank to fill completely then empty. This first tank of water flushes the entire system removing any preservatives used during storage.

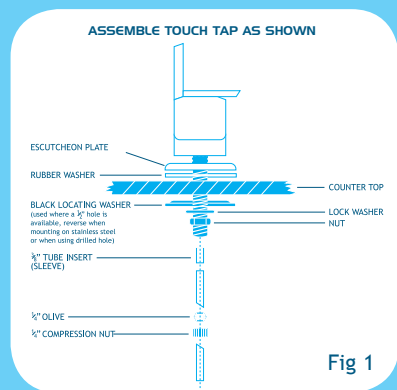

Preventative maintenance

It is very important to follow the procedures below to ensure that your water system continues to function properly.

Approximate cartridge life:

Prefilter, Pre carbon filter and Postfilter - 6 months

Reverse Osmosis Membrane - 2 to 3 years

1. Changing the Prefilter: First turn off the cold water supply and allow the system to depressurise for about 10 minutes. Using a filter wrench to unscrew the prefilter housing and remove the filter cartridge. Replace with a new prefilter cartridge; inspect the o-ring in the filter housing and lubricate it with silicone grease. Screw the housing back and go on to step 2.

2. Changing the Pre carbon filter: Repeat the instructions as in 1.

3. Changing the Post filter: Turn off the tank valve and open the drinking water tap to relieve the pressure. Close it and, using a filter wrench, unscrew the post filter housing and remove the filter cartridge. Inspect the o-ring in the filter housing and lubricate it with silicone grease. Screw the housing back on and go to step 4.

4. Start up: Make sure that all the tubes are properly connected to the filters. Open the drinking water tap on the sink and the valve on the tank. Allow at least 1 gallon to run down the drain before closing the drinking water tap. Turn on the cold water supply and allow the system to pressurise.

5. Changing the Reverse Osmosis Membrane: When replacing the membrane the prefilter and postfilter should also be changed. Follow steps 1, 2 and 3 then proceed to disconnect the compression fittings from the membrane and remove the mounting clips. Connect the new membrane and follow the instructions in step 4.

6. It is recommended that the storage tank be emptied at least once a month. Open the tap to allow the water to drain until empty. Close the drinking water tap and the tank will refill in 10 to 12 hours.

7. Product water should be tested once or twice a year to ensure that the membrane is removing the impurities adequately. This may be done by obtaining a water TDS meter.

Parts and service are available. Contact to request the parts and/or service required.

Troubleshooting

Symptom	Likely Cause	Solution
No water production	Water supply is turned off Storage vessel shut off valve turned off Tubes are bent	Turn water supply on Turn shut off valve on Straighten tubes
Not enough water	Booster pump is not plugged in Booster pump is not working Hole cut by self piercing valve is blocked Clogged pre filter cartridge Pressure in storage vessel is low RO membrane is clogged or fouled	Plug booster pump in Check fuse in supplied plug Replace if necessary. Check your power supply. Rotate hand wheel on self piercing valve to try to clear restriction. Replace self piercing valve if necessary Replace Attach pressure gauge to nipple on storage vessel. Increase pressure if it is less than 8psi. Replace RO membrane. Check water quality is within parameters.
Leaking drain assembly	Misalignment of hole in drain pipe with hole in drain clamp	Realign drain clamp

Troubleshooting

Leak from hole in the air gap touch tap	Lower section of hole is blocked Red pipe from touch tap to drain clamp has a kink or is blocked. Water has forced its way back up the drain pipe by another device using the drain pipe eg. washing machine	Clear hole Realign red pipe. Clear blockage. Check configuration of drain to device causing problem and correct
Excessive noise coming from the touch tap	Excessive slack or too much tension in the pipes	Ensure all pipe runs either as horizontal or vertical as possible. Adjust position of pipes until noise is reduced.
Water has an offensive taste and/or odour	Post filter is depleted Pre-filters are depleted Membrane depleted or fouled the RO system Sanitise not flushed out	Replace post filter Replace pre-filters Replace membrane and sanitise Drain the storage vessel and let it fill overnight
Leak from the filter housing or RO membrane housing	Damaged or misaligned 'O' ring	Replace or reposition the 'O' ring
Leaking nuts or push connections	Nuts not properly tightened or not properly installed Push connections not installed properly	Use PTFE tape to ensure a water tight seal Re-install push connections
TDS in product water is high	Pressure to the RO membrane is low or the booster pump pressure is below 80psi RO membrane is depleted	Replace pre-filters Check booster pump is working Replace membrane and sanitise
Pump is working but RO not producing water	Pressure equalising valve is faulty Low and high pressure switches faulty	Replace Replace
Pump not functioning	Incoming pressure less than 1 bar Burnt out booster pump	Bypass the connection to the low pressure switch for temporary use. Replace pump
Pump is cycling abnormally on and off	Pre-filters clogged	Replace filters