

SPECIFICATION FOR APPROVAL

Description : Magnetic Buzzer

Specification No. : TKS-7084

Number Of The Edition : 1.3

CUSTOMER'S APPROVED SIGNATURE		

Approved by	Checked by	Issued by

A. SCOPE

This specification applies magnetic buzzer, **KXG1212C**

B. SPECIFICATION

No.	Item	Unit	Specification	Condition
1	Rated Voltage	V _{DC}	12.0	
2	Operating Volt.	V _{DC}	8.0~16.0	
3	Mean Current	mA	Max.35	
4	Sound Output	dBA	Min.85 (Typical 94)	Distance at 10cm(A-weight free air). Applying rated voltage .
5	Resonant Frequency	Hz	2300 ± 300	
6	Operating Temp.	°C	-30 ~ +70	
7	Storage Temp.	°C	-40 ~ +85	
8	Dimension	mm	φ 12.0 × H9.5	See attached drawing.
9	Weight	gram	1.60	
10	Material		PPO(Black)	
11	Terminal		Pin type (Plating Au)	See attached drawing.
12	Environmental Protection Regulation		RoHS2.0	

C. TYPICAL FREQUENCY RESPONSE CURVE

VOLTAGE-SOUND PRESSURE LEVEL

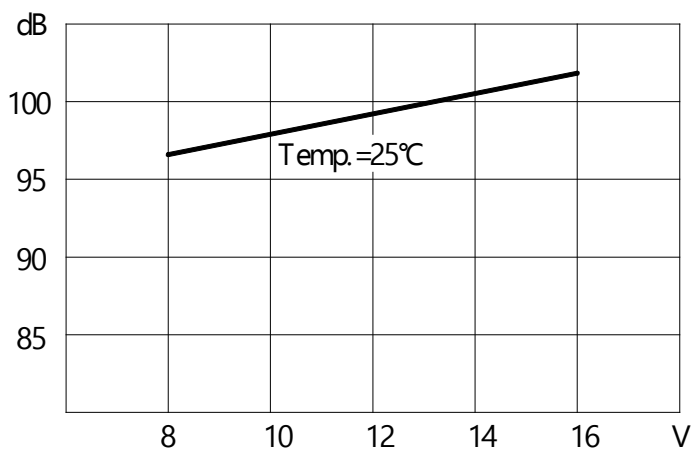

VOLTAGE-CURRENT CONSUMPTION

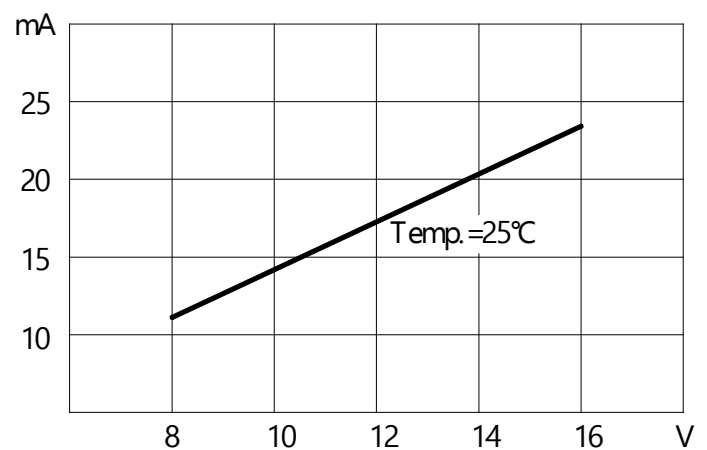

D. APPEARANCE DRAWING

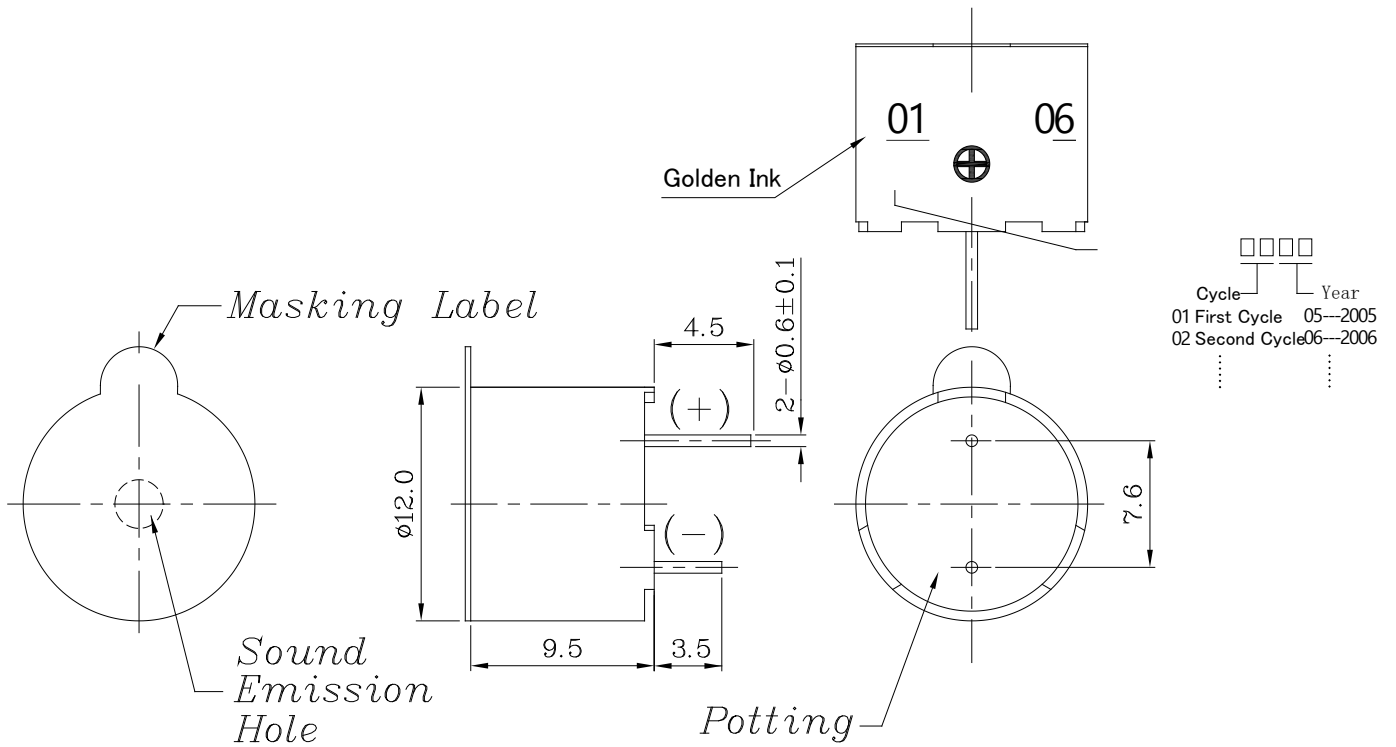

Tol: ± 0.5
Unit: mm

E. SOLDERING SPEC

- MANUAL SOLDERING: 350°C ~ 400°C, WITHIN 4 SECS.
- WAVE SOLDERING: SEE BELOW DIAGRAM

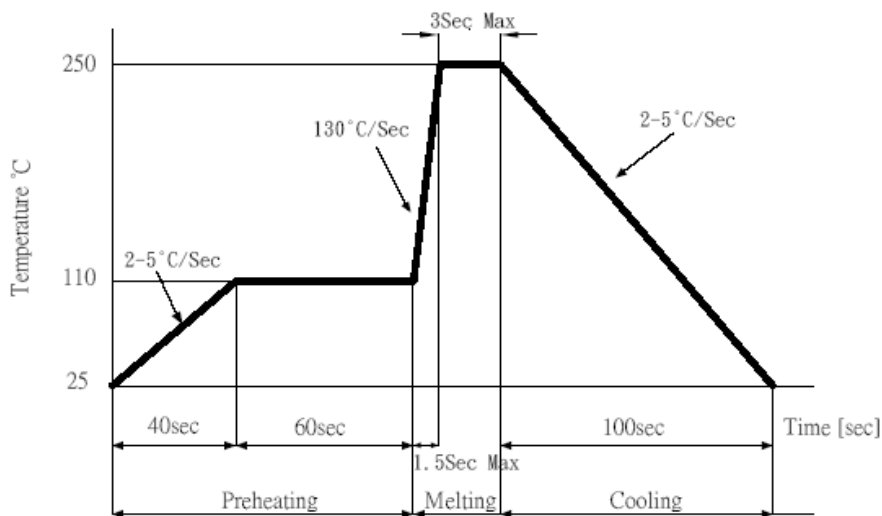

F. MEASUREMENT METHOD

+V DC

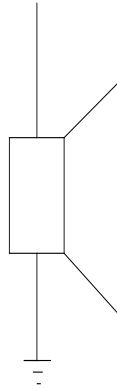

G. MECHANICAL CHARACTERISTICS

No.	Item	Test condition	Evaluation standard
1	Solderability	Lead terminals are immersed in rosin for 5 seconds and then immersed in solder bath of $+270\pm 5^{\circ}\text{C}$ for 3 ± 1 seconds.	90% min. lead terminals shall be wet with solder. (Except the edge of terminal)
2	Soldering Heat Resistance	Lead terminal are immersed up to 1.5mm from sounder's body in solder bath of $+260\pm 5^{\circ}\text{C}$ for 3 ± 1 seconds.	No interference in operation
3	Terminal Mechanical Strength	The force 10 seconds of 9.8N(1.0kg) is applied to each terminal in axial direction.	No damage and cutting off
4	Vibration	Buzzer shall be measured after being applied vibration of amplitude of 1.5mm with 10 to 55hz band of vibration frequency to each of 3 per-pendicular directions for 2 hours.	After the test the part shall meet specifications with-out any damage in appearance and the SPL should be in $\pm 10\text{dBA}$ compared with initial one.
5	Drop test	The part only shall be dropped from a height of 75cm onto a 40mm thick wooden board 3 times in 3 axes (X.Y.Z). (a total of 9 times).	

H. ENVIRONMENT TEST

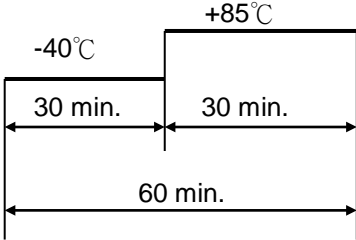
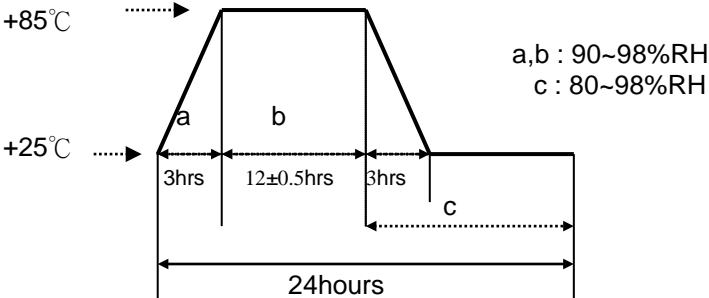
No.	Item	Test condition	Evaluation standard
1	High temp. test	After being placed in a chamber at +85°C for 96 hours.	After the test the part shall meet specifications with-out any degradation in appearance and performance except SPL. after 4 hours at +25°C. the SPL should be in ±10dBA compared with initial one.
2	Low temp. test	After being placed in a chamber at -40°C for 96 hours.	
3	Thermal Shock	<p>The part shall be subjected to 10 cycles. One cycle shall consist of;</p> 	
4	Temp./ Humidity Cycle	<p>The part shall be subjected to 10 cycles. One cycle shall be 24 hours and consist of;</p> 	

I. RELIABILITY TEST

No.	Item	Test condition	Evaluation standard
1	Operating life test	<p>1. Continuous life test The part shall be subjected to 72 hours at +55°C with 12VDC applied.</p> <p>2. Intermittent life test A duty cycle of 1 minute on, 1 minutes off, a minimum of 10000 times at room temp.(+25±10°C) with 12VDC applied.</p>	After the test the part shall meet specifications with-out any degradation in appearance and performance except SPL. after 4 hours at +25°C. the SPL should be in ±10dBA compared with initial one.

TEST CONDITION.

Standard Test Condition : a) Temperature : +5 ~ +35°C b) Humidity : 45-85% c) Pressure : 860-1060mbar
 Judgement Test Condition : a) Temperature : +25 ± 2°C b) Humidity : 60-70% c) Pressure : 860-1060mbar

J.PACKING STANDARD

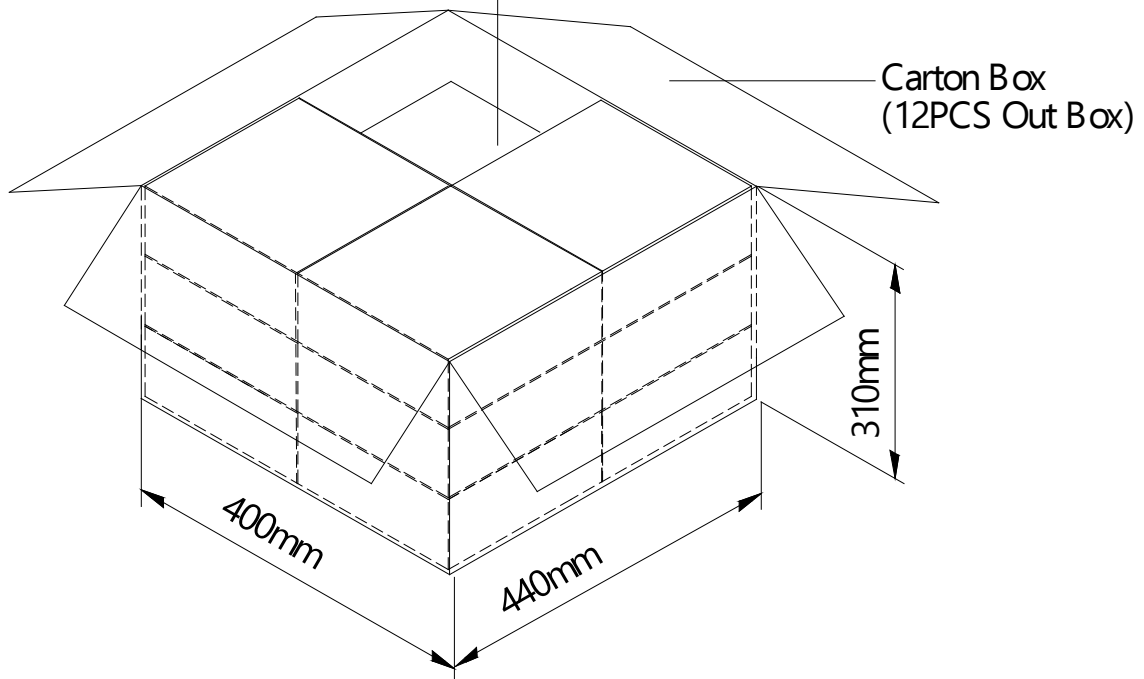
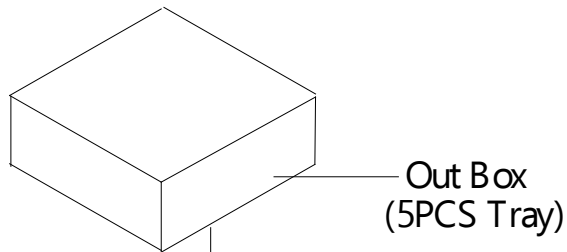
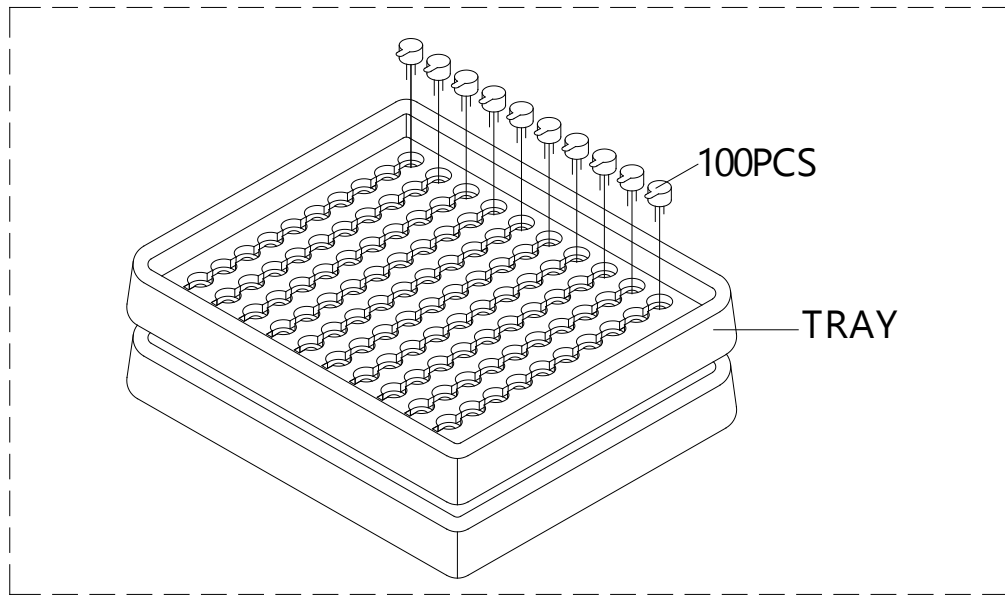

Tray	184mmx184mmx23mm	1x100PCS=100PCS
Out Box	200mmx190mmx100mm	5LAYERx100PCS=500PCS
Carton Box	440mmx400mmx310mm	500PCSx12=6000PCS