

Datasheet

RS Stock No. 1253593

RS Pro Twin Diaphragm High Flow Gas Micro-pump

Overview : Gas Pump, Very Efficient, Good Pressure and Vacuum

The D3K pumps are miniature diaphragm pumps designed for maximum performance with minimum power consumption making them especially suitable for portable, battery powered devices.

They are constructed from a special blend of Polycarbonate and ABS for maximum strength and rigidity and have elastomeric components manufactured from Nitrile. They are powered by a small and highly efficient coreless DC motor for ultimate efficiency.

The dual inlet and outlet ports allow the two pump heads to be plumbed in series for maximum pressure and vacuum or in parallel for maximum flow.

Pump

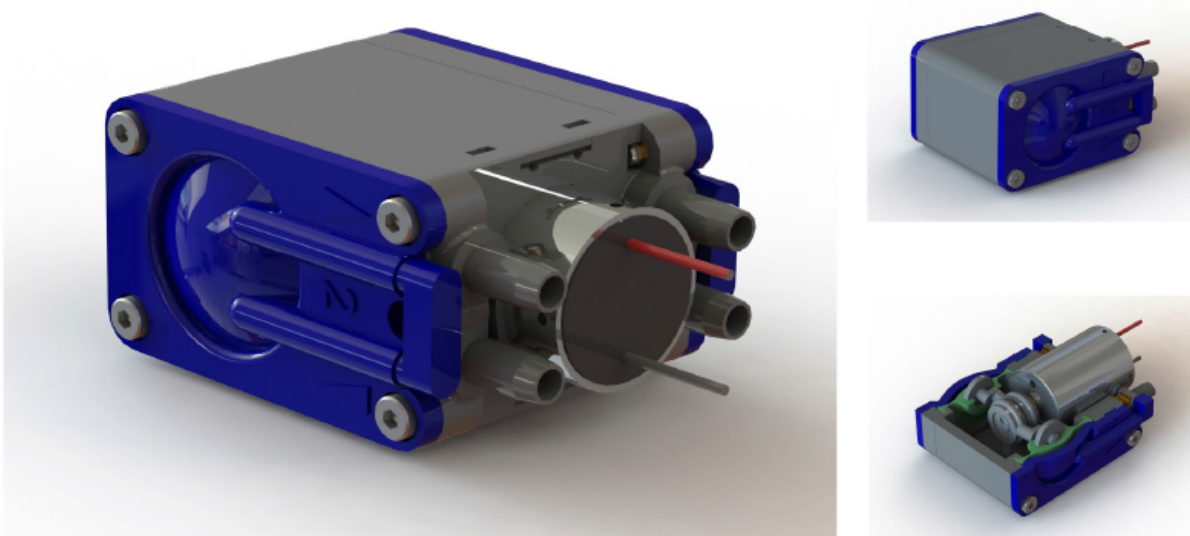

Typical Applications

- Medical devices
- Analysis Systems
- Gas detection and monitoring
- Cooling Systems
- Precision Flow

Features

- High Efficiency
- High flow rate
- Good performance under suction
- Low power consumption
- Small size only 36 x 23 x 43 mm
- Light weight 45g
- Robust design
- Can be user optimised for either best flow or pressure

Datasheet

RS Stock No. 1253593

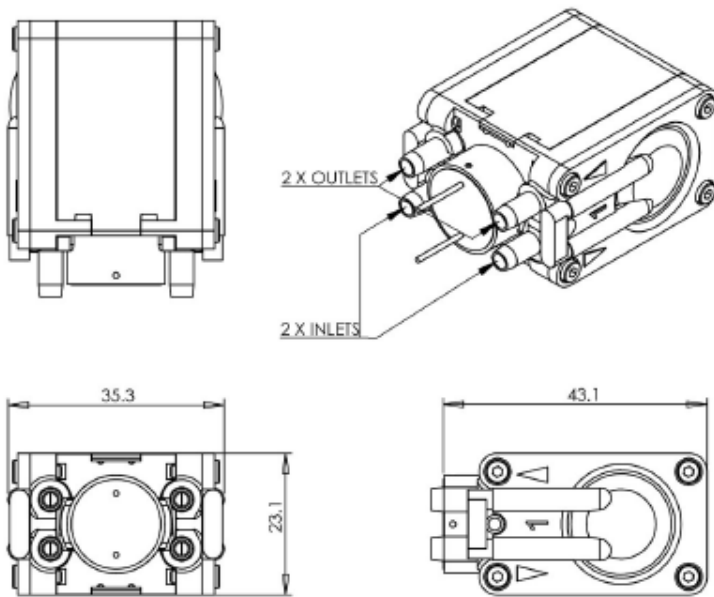

Materials

Wetted Parts

- PC / ABS Polymer
- Nylon 66
- Nitrile

Other Components

- DC Motor
- Acetal
- 316 Stainless Steel

Custom versions available for chemical compatability

Heads Connected in Series

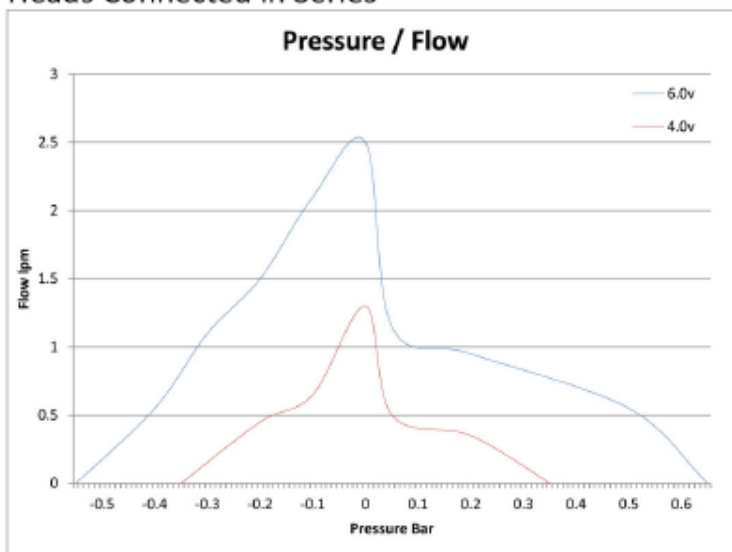

Performance Data

- Operating Voltage 3-6 volts DC
 - Power Consumption 0.3 - 2.5 watts
 - Small Size 36 x 23 x 43mm
 - Weight 45g
 - Operating Temp 0 to 60 deg C
 - IP Rating IP41
 - Noise Levels <25db
- Measured at a distance of 1m with a 50dB ambient noise level and with the pumps inlet and outlet ports silenced
- MTBF 3,000hrs

Custom configurations available for upto 20,000 hrs

Datasheet
RS Stock No. 1253593

Heads Connected in Parallel

