



Main

Range of product	Modicon TM3
Product compatibility	Logic controller Motion controller
Product or component type	I/O distributed module
Product specific application	Bus coupler module

Complementary

Communication port protocol	Ethernet IP/Modbus TCP
Connector type	RJ45 2 Ethernet daisy chain isolated USB device port Mini-B
Exchange mode	Half duplex, full duplex, autonegotiation
Transmission rate	10/100 Mbit/s
Topology	Daisy chain
Port Ethernet	10/100BASE-T
Communication network type	Ethernet IP Modbus TCP IPv4 (internet protocol)
Communication service	Ethernet/IP adapter Modbus TCP/IP server RSTP (Ring topology support) SNMP Web server DHCP client BOOTP Address conflict detection FTP server
Web services	Web server, Ethernet Web server, USB
Current consumption	0.8 A at 24 V DC internal supply maximum 7 expansion modules
Local signalling	1 LED green/red for PWR (System Status) 1 LED green/red for MS (Module Status) 1 LED green/red for NS (Network Status) 1 LED green/red for I/O status
Fixing mode	By clipping locks (rail) By screws (mounting plate)
Product certifications	CE CULus EAC RCM UKCA EU-RO MR
Standards	EN 61131-2 UL/CSA 61010-1 UL/CSA 61010-2-201
Width	27 mm
Height	96.5 mm
Depth	70 mm
Product weight	0.10 kg

The information provided in this documentation contains general descriptions and/or technical characteristics of the performance of the products contained herein. This documentation is not intended as a substitute for and is not to be used for determining suitability or reliability of these products for specific user applications. It is the duty of any such user or integrator to perform the appropriate and complete risk analysis, evaluation and testing of the products with respect to the relevant specific application or use thereof. Neither Schneider Electric Industries SAS nor any of its affiliates or subsidiaries shall be responsible or liable for misuse of the information contained herein.

Environment

Ambient air temperature for storage	-25...70 °C
Pollution degree	2
Ambient air temperature for operation	-10...60 °C
IP degree of protection	IP20 conforming to IEC/EN 61010-2-201
Relative humidity	10...95 % non-condensing
Operating altitude	0...2000 m
Storage altitude	0...3000 m
Vibration resistance	3M4 on 35 x 15 mm symmetrical DIN rail

Packing Units

Unit Type of Package 1	PCE
Number of Units in Package 1	1
Package 1 Height	7.4 cm
Package 1 Width	10.4 cm
Package 1 Length	12.4 cm
Package 1 Weight	172.0 g
Unit Type of Package 2	S03
Number of Units in Package 2	18
Package 2 Height	30.0 cm
Package 2 Width	30.0 cm
Package 2 Length	40.0 cm
Package 2 Weight	3.75 kg

Offer Sustainability

Sustainable offer status	Green Premium product
REACH Regulation	REACH Declaration
EU RoHS Directive	Pro-active compliance (Product out of EU RoHS legal scope) EU RoHS Declaration
Mercury free	Yes
China RoHS Regulation	China RoHS Declaration
RoHS exemption information	Yes
Environmental Disclosure	Product Environmental Profile
Circularity Profile	End Of Life Information
PVC free	Yes
California proposition 65	WARNING: This product can expose you to chemicals including: Lead and lead compounds, which is known to the State of California to cause cancer and birth defects or other reproductive harm. For more information go to www.P65Warnings.ca.gov

Dimensions

Side and Front Views

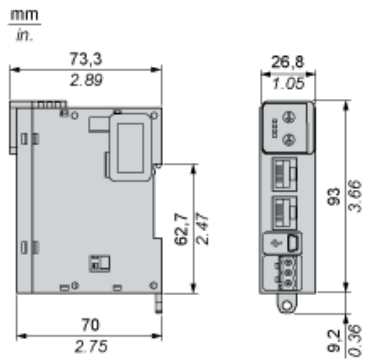

Spacing Requirements

