

MD20A - 24



Modulating Damper Actuator Action 20 Nm (180 in-lb)

MD20A-24 damper actuators for operating air control dampers in ventilation and air-conditioning systems for building services installations

- For air control dampers up to approx. 4 m² (4.8 yard²)
- Torque 20 Nm (180 in-lb)
- Nominal voltage AC/DC 24 V
- Control: Modulating 0 – 10 V
- Position feedback: 2 – 10 V

SPECIFICATIONS

Part number 875-1029-000
 Power supply 24 V AC ±20%, 50–60 Hz,
 24 V DC ±20%

Power consumption

In operation 2 W @ nominal torque
 At res 0.4 W
 For wire sizing 4 VA
 Connection cable 1 m (3.3 ft), 4×0.75 mm²
 (AWG 18)

Control signal X 0–10 V DC
 Input resistance 100 k Ohm
 Operating range 2–10 V DC
 (for set angle of rotation)

Synchronisation tolerance ±5%
 Position feedback Y 2–10 V DC (max. 1 mA)
 Direction of rotation . . . Reversible with switch 0 / 1
 at switch position 0 ↺ resp. 1 ↻

Angle of rotation max. 95°
 (adjustable by mechanical stops)

Torque . . min. 20 Nm (180 in-lb) @ nominal voltage
 Running time 150 s
 Position indication mechanical
 Manual override Gearing latch disengaged
 with pushbutton, self-resetting, manual locking

Standards conformity

EMC, emission SS EN 50081-1
 EMC, immunity SS EN 50082-1
 Protection class III Safety extra-low voltage
 Enclosure rating IP 54
 Ambient humidity 95% r.H (EN 60730-1)

Ambient temperature

Operation –30 to +50 °C (–22 to +122 °F)
 Storage –40 to +80 °C (–40 to +176 °F)
 Sound power level max. 45 dB (A)
 Maintenance Maintenance-free
 Weight Approx 1.05 kg (2.3 lb.)

DIMENSIONS mm (in)

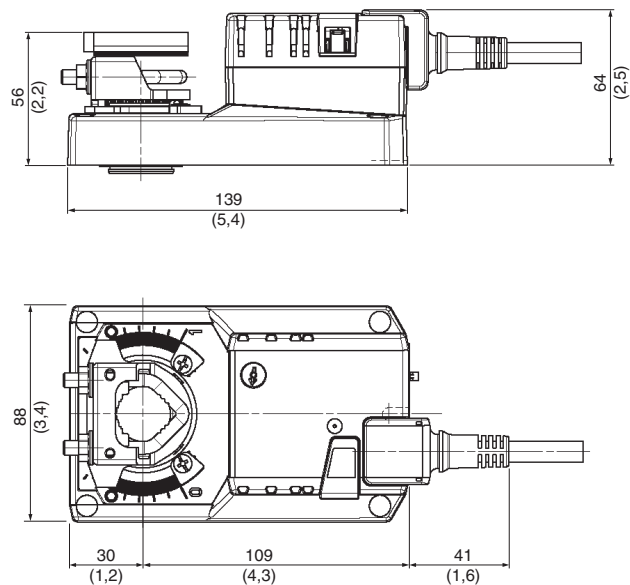

Damper spindle (in.)	Length mm (in.)	⊘ mm
Clamp on top	min. 42 (1.65)	10 ... 20 (0.39 ... 0.78)
Clamp on bottom	min. 20 (0.78)	10 ... 20 (0.39 ... 0.78)

FUNCTION

Mode of operation

The actuator is controlled by means of a standard control signal DC 2-10 V. It opens to the position dictated by this signal. The measuring voltage Y allows the damper position (0 ... 100%) to be electrically indicated and serves as a follow-up control signal for other actuators.

Simple direct mounting

Simple direct mounting on the damper spindle with a universal spindle clamp, supplied with an anti-rotation strap to prevent the actuator from rotating.

Manual override

Manual operation is possible with the self-resetting pushbutton (the gearing latch remains disengaged as long as the pushbutton is pressed or detented).

Adjustable angle of rotation

Adjustable angle of rotation with mechanical end stops.

High functional reliability

The actuator is overload-proof, requires no limit switches and automatically stops when the end stop is reached.

SAFETY NOTES

 **The damper actuator is not allowed to be used outside the specified field of application, especially in aircraft.**

The device may only be opened at the manufacturer's site. It does not contain any parts that can be replaced or repaired by the user.

The cable must not be removed from the device.

When calculating the required torque, the specifications supplied by the damper manufacturers (cross section, design, installation site), and the air flow conditions must be observed.

 **The device contains electrical and electronic components and is not allowed to be disposed of as household refuse. All locally valid regulations and requirements must be observed.**

WIRING

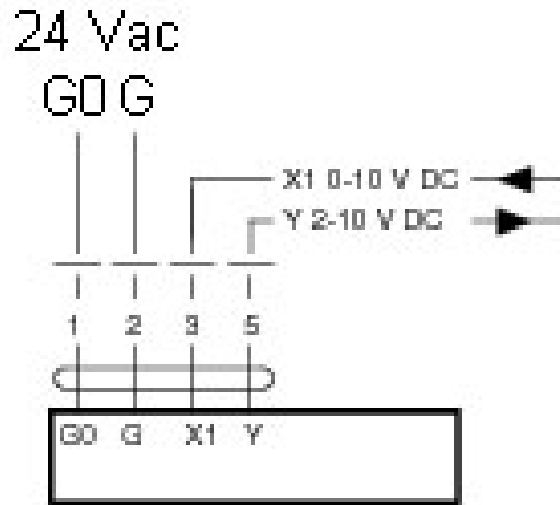

WIRING

MD10B-230



Connection via safety isolating transformer.

Measuring voltage Y for position indication or as master-slave signal.

Parallel connection of several actuators is possible. Power consumption must be observed.

ACCESSORIES

Please refer to data sheet G-30-90

“Accessories Damper Actuators”
(part. no. 0-003-2251).