

Fibre Optic Receiver Jack multicomp^{PRO}

RoHS
Compliant



Features

- High PD sensitivity for red light
- High speed up to 16 Mbps
- Low power consumption and current dissipation
- +3 to +5V power source

Descriptions

The light receiving unit is a standard-package product with connector and opto-electric component packaged with PD and I/V amplifier IC. The function of unit changes the light signal into electric signal.

The unit is operated at +3 to +5V and the input signal is TTL compatible. This product has a maximum operating speed of 16 Mbps.

Applications

- Audio equipment
- Digital optical data link
- MD
- Sound card

Diagram

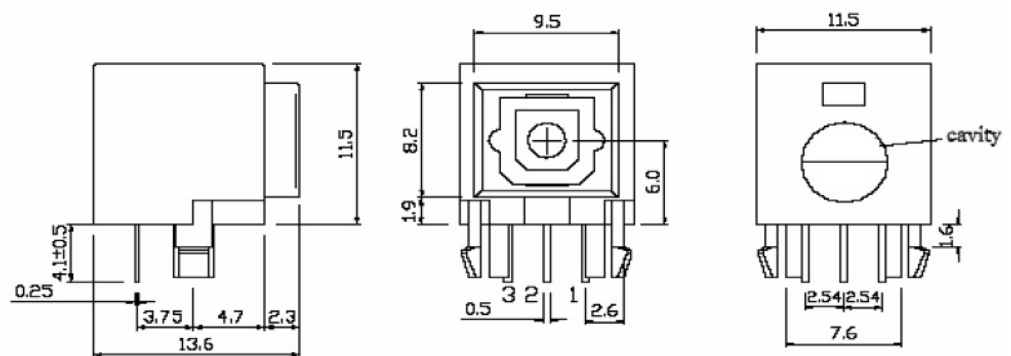

Pin	Function
1	Vout
2	GND
3	Vcc

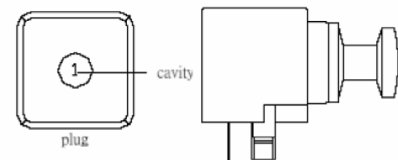

Notes : General Tolerance:±0.2mm

Dimensions : Millimetres

Newark.com/multicomp-pro
Farnell.com/multicomp-pro
sg.element14.com/b/multicomp-pro

multicomp^{PRO}

Fibre Optic Receiver Jack multicom^{PRO}

Specification

Chip		Operating Voltage (Vcc)	Dissipation Current(mA)	Fiber Coupling Light Output (dBm)		
IC Material	LED λ (nm)		Typ.	Min.	Typ.	Max.
Si	650	2.7 to 5.5	6.5	-24	-	-14.5

Absolute Maximum Ratings(Ta = 25°C)

Parameter	Symbol	Rating	Unit
Supply Voltage	Vcc	5.5	V
Storage Temperature	Tstg	-30 to +80	°C
Operating Temperature	Topr	-20 to +70	°C
Soldering Temperature	Tsol	260*	°C

* Soldering time \leq 5s / 2times.

*Don't touch flux soldering and white Gas

Electro-Optical Characteristics

Parameter	Symbol	Conditions	MIN.	TYP.	MAX.	Unit
Operating Voltage	Vcc	-	2.7	-	5.5	V
Peak Detective Wavelength	λ p	-	-	650	-	nm
Transfer Speed		NRZ signal	0.1	-	16	Mbps
Receiving Distance		Using APF	0.2	-	20	m
Pulse Width Distortion	Δ tw	16Mbps NRZ Signal	-20	-	20	ns
Input Light power	Pi	*1	-24	-	-14.5	dBm
Dissipation Current	Icc	*2	-	-	10	mA
High Level Output Voltage	V _{OH}		2.4	-	-	v
Low Level Output Voltage	V _{OL}		-	-	0.4	v
Rise Time	t _r	*3	-	-	25	ns
Fall Time	t _f	*3	-	-	25	ns
Low \rightarrow High propagation delay time	t _{PLH}	*3	-	-	100	ns
High \rightarrow Low propagation delay time	t _{PHL}	*3	-	-	100	ns
Jitter	Δ tj	*3	-	1.5	15	ns

Light receiving unit satisfies EIAJ CP-1201 digital audio interface standard.

Fibre Optic Receiver Jack multicomp^{PRO}

PCB Layout For Electrical Circuit

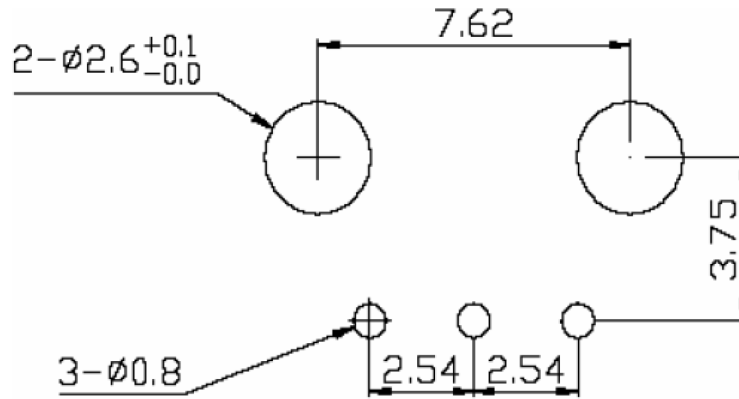

Notes:

- 1. Unit: mm
- 2. Unspecified tolerance: ± 0.3 mm
- 3. Substrate Thickness: 1.6mm

Part Number Table

Description	Part Number
Fibre Optic Receiver Jack, 16 Mbps, -24dBm, 5.5V, 6.5mA	MP-FCR6842032R

Important Notice : This data sheet and its contents (the "Information") belong to the members of the AVNET group of companies (the "Group") or are licensed to it. No licence is granted for the use of it other than for information purposes in connection with the products to which it relates. No licence of any intellectual property rights is granted. The Information is subject to change without notice and replaces all data sheets previously supplied. The Information supplied is believed to be accurate but the Group assumes no responsibility for its accuracy or completeness, any error in or omission from it or for any use made of it. Users of this data sheet should check for themselves the Information and the suitability of the products for their purpose and not make any assumptions based on information included or omitted. Liability for loss or damage resulting from any reliance on the Information or use of it (including liability resulting from negligence or where the Group was aware of the possibility of such loss or damage arising) is excluded. This will not operate to limit or restrict the Group's liability for death or personal injury resulting from its negligence. Multicomp Pro is the registered trademark of Premier Farnell Limited 2019.

Newark.com/multicomp-pro
 Farnell.com/multicomp-pro
 sg.element14.com/b/multicomp-pro

multicomp^{PRO}