



**MITSUBISHI
ELECTRIC**

Safety Guidelines

Thank you for purchasing the Mitsubishi programmable controller MELSEC-Q series.

Prior to use, please read this and relevant manuals thoroughly to fully understand the product.

MELSEC-Q

Mitsubishi Programmable
Controller

MODEL	Q3NB-U-HW
MODEL CODE	13JY83
IB(NA)-0800423-V(1608)MEE	

● SAFETY PRECAUTIONS ●

(Read these precautions before using this product.)

Before using this product, please read this manual and the relevant manuals carefully and pay full attention to safety to handle the product correctly. If products are used in a different way from that specified by manufacturers, the protection function of the products may not work properly.

In this manual, the safety precautions are classified into two levels:

"⚠ WARNING" and "⚠ CAUTION".

WARNING

Indicates that incorrect handling may cause hazardous conditions, resulting in death or severe injury.

CAUTION

Indicates that incorrect handling may cause hazardous conditions, resulting in minor or moderate injury or property damage.

Under some circumstances, failure to observe the precautions given under "⚠ CAUTION" may lead to serious consequences.

Observe the precautions of both levels because they are important for personal and system safety.

Make sure that the end users read this manual and then keep the manual in a safe place for future reference.

[Design Precautions]

WARNING

- Configure safety circuits external to the programmable controller to ensure that the entire system operates safely even when a fault occurs in the external power supply or the programmable controller. Failure to do so may result in an accident due to an incorrect output or malfunction.
 - (1) Configure external safety circuits, such as an emergency stop circuit, protection circuit, and protective interlock circuit for forward/reverse operation or upper/lower limit positioning.
 - (2) The programmable controller stops its operation upon detection of the following status, and the output status of the system will be as shown below.

	Q series module	AnS/A series module
Overcurrent or overvoltage protection of the power supply module is activated.	All outputs are turned off	All outputs are turned off
The CPU module detects an error such as a watchdog timer error by the self-diagnostic function.	All outputs are held or turned off according to the parameter setting.	All outputs are turned off

All outputs may turn on when an error occurs in the part, such as I/O control part, where the CPU module cannot detect any error. To ensure safety operation in such a case, provide a safety mechanism or a fail-safe circuit external to the programmable controller. For a fail-safe circuit example, refer to "General Safety Requirements" in this manual.

- (3) Outputs may remain on or off due to a failure of an output module relay or transistor. Configure an external circuit for monitoring output signals that could cause a serious accident.
- In an output circuit, when a load current exceeding the rated current or an overcurrent caused by a load short-circuit flows for a long time, it may cause smoke and fire. To prevent this, configure an external safety circuit, such as a fuse.
 - Configure a circuit so that the programmable controller is turned on first and then the external power supply.
If the external power supply is turned on first, an accident may occur due to an incorrect output or malfunction.
 - For the operating status of each station after a communication failure, refer to relevant manuals for the network. Incorrect output or malfunction due to a communication failure may result in an accident.

[Design Precautions]

WARNING

- When connecting a peripheral with the programmable controller CPU or connecting a personal computer with an intelligent function module to modify data of a running programmable controller, configure an interlock circuit in the sequence program to ensure that the entire system will always operate safely. For other forms of control (such as program modification, parameter change, forced output, or operating status change) of a running programmable controller, read the relevant manuals carefully and ensure that the operation is safe before proceeding.
Especially, when a remote programmable controller is controlled by an external device, immediate action cannot be taken if a problem occurs in the programmable controller due to a communication failure.
To prevent this, configure an interlock circuit in the sequence program, and determine corrective actions to be taken between the external device and CPU module in case of a communication failure.
- Do not write any data to the write prohibited area of the buffer memory in the intelligent function module. Also, do not use any "use prohibited" signal as an output signal from the CPU module to the intelligent function module. Doing so may cause malfunction of the programmable controller system. For the write prohibited area or use prohibited signal, refer to the user's manual for each intelligent function module.
- If a communication cable is disconnected, the network may be unstable, resulting in a communication failure of multiple stations. Configure an interlock circuit in the program to ensure that the entire system will always operate safely even if communications fail. Failure to do so may result in an accident due to an incorrect output or malfunction.
- To maintain the safety of the programmable controller system against unauthorized access from external devices via the network, take appropriate measures. Also, to maintain the safety of the programmable controller system against unauthorized access from external devices via the Internet, take measures such as a firewall.

[Design Precautions]

WARNING

Precautions for using positioning modules

- Configure safety circuits external to the programmable controller to ensure that the entire system operates safely even when a fault occurs in the external power supply or the programmable controller. Failure to do so may result in an accident due to an incorrect output or malfunction.
 - (1) Configure an emergency stop circuit and interlock circuit such as a positioning control upper limit/lower limit to prevent mechanical damage outside the programmable controller.
 - (2) Machine OPR (Original Point Return) is controlled by two kinds of data: an OPR direction and an OPR speed. Deceleration starts when the near-point watchdog signal turns on. If an incorrect OPR direction is set, motion control may continue without deceleration. To prevent machine damage caused by this, configure an interlock circuit external to the programmable controller.
 - (3) When the module detects an error, deceleration stop will take place. Make sure that the OPR data and positioning data are within the parameter setting values.

Precautions for using Ethernet interface modules

- To prevent the malfunction of the programmable controller system due to harmful e-mails, take preventive measures (such as antivirus measures) so that the mail server for this module does not receive harmful e-mails.

Precautions for using Web server modules

- When the e-mail function is utilized, it may take time to send e-mail or is disabled depending on the status of the send server, transmission path, receive server and/or receive device. Configure a circuit to notify an error using a lamp and a buzzer to ensure the safety of the programmable controller system.

Precautions for using CC-Link IE Controller Network modules

- The optical transmitter and receiver of the head module use laser diodes (class 1 in accordance with IEC 60825-1). Do not look directly at a laser beam. Doing so may harm your eyes.

[Design Precautions]

WARNING

Precautions for using MELSECNET/H network modules

- In the case of a communication failure in the network, the status of the error station will be as follows. Check the communication status information and configure an interlock circuit in the sequence program to ensure that the entire system will operate safely. Failure to do so may result in an accident due to an incorrect output or malfunction.
 - (1) The remote master station will hold the data from before the communication error.
 - (2) The remote I/O station turns off all outputs. The output module of the remote I/O station can clear/hold the output status at the time of error by using the remote I/O module parameters. As the parameters are set to "clear" by default, the output module turns off the outputs at the time of error. In case that the system operates safely when the output is held, set the parameter to "Hold".

Precautions for using CC-Link system master/local modules

- To set the auto refresh parameter, select the device Y for the remote output (RY) refresh device. If a device other than Y, such as M and L, is selected, the CPU module holds the device status even after its status is changed to STOP. Refer to the CC-Link System Master/Local Module User's Manual for how to stop the data link.

Precautions for using serial communication modules

- When using the notification function, the pager receiver may not be contacted due to the frequency transmission status from the system setup environment and error on the receiver side. Configure a circuit to notify an error using a lamp and a buzzer to ensure the safety of the programmable controller system.

Precautions for using FL-net(OPCN-2) interface modules

- Refer to FL-net (OPCN-2) Interface Module User's Manual for information about the operation of each node when the cyclic transmission generates a communication error when using FL-net (OPCN-2). Incorrect output or malfunction due to a communication failure may result in an accident.

[Design Precautions]

WARNING

Precautions for using AS-i master modules

- If a communication error occurs in the AS-i system, the input will turn OFF from the slave having the communication error. Output to the slave having the communication error will be held or cleared depending on the slave specifications. The AS-i system communication error can be confirmed with the buffer memory's List of Active Slaves (LAS) (15_H to 18_H) and with the input signal Configuration error (X4). Using the above information, configure an interlock circuit on the sequence program so that the system activates safely. Failure to do so may result in an accident due to an incorrect output or malfunction.
- Depending on the module fault, the input/output could enter ON or OFF status. Provide an external monitoring circuit for I/O signals that could lead to major accidents.

Precautions for using intelligent communication modules

- When connecting a peripheral device to the CPU module or performing control of a programmable controller which is being run through a BASIC program, configure an interlock circuit in the sequence program so that the system overall is operating on the safe side at all times. Also before exercising other control (program change, operating status change (status control)) on the running programmable controller, read the Q Corresponding Intelligent Communication Module User's Manual carefully and fully confirm safety. Especially, when a remote programmable controller is controlled by an external device, immediate action cannot be taken if a problem occurs in the programmable controller due to a communication failure. To prevent this, configure an interlock circuit in the sequence program, and determine corrective actions to be taken between the external device and CPU module in case of a communication failure.

[Design Precautions]

WARNING

Precautions for using products in a Class I, Division 2 environment

- Products with the Cl.I, DIV.2 mark on the rating plate are suitable for use in Class I, Division 2, Groups A, B, C and D hazardous locations, or nonhazardous locations only. This mark indicates that the product is certified for use in the Class I, Division 2 environment where flammable gases, vapors, or liquids exist under abnormal conditions. When using the products in the Class I, Division 2 environment, observe the following to reduce the risk of explosion.
 - This device is open-type and is to be installed in an enclosure suitable for the environment and require a tool or key to open.
 - Warning - Explosion Hazard - Substitution of any component may impair suitability for Class I, Division 2.
 - Warning - Explosion Hazard - Do not disconnect equipment while the circuit is live or unless the area is known to be free of ignitable concentrations.
 - Do not open the cover of the CPU module and remove the battery unless the area is known to be nonhazardous.
 - All MELSEC-Q modules (except base modules) are to be connected to a base module only.
 - Do not connect or disconnect cable while power is applied unless area is known to be nonhazardous to/from the RS-232 connector of the CPU module and the MELSECNET/H remote I/O module. RS-232 connector is for maintenance only and is not intended for permanent connection.
 - Connect the RS-232 connection cable (QC30R2) manufactured by Mitsubishi to the RS-232 connector of the CPU module. If using the cable for a constant connection, fix it with the RS-232 connector disconnection prevention holder (Q6HLD-R2) to prevent an accidental disconnection.

[Design Precautions]

CAUTION

- Do not install the control lines or communication cables together with the main circuit lines or power cables.
Keep a distance of 100mm or more between them.
Failure to do so may result in malfunction due to noise.
- When a device such as a lamp, heater, or solenoid valve is controlled through an output module, a large current (approximately ten times greater than normal) may flow when the output is turned from off to on.
Take measures such as replacing the module with one having a sufficient current rating.
- After the CPU module is powered on or is reset, the time taken to enter the RUN status varies depending on the system configuration, parameter settings, and/or program size.
Design circuits so that the entire system will always operate safely, regardless of the time.
- During setting registration, do not turn off the power of the station where a module is connected. Do not reset the CPU module either. Doing so may cause unstable data in a flash ROM or compact flash card, result in the setting or registration required again. Also, this may cause the module to fail or malfunction.

Precautions for using digital-analog converter modules

- At power-on or power-off, a voltage or current may flow between output terminals momentarily. In this case, start the control after analog outputs become stable.

Precautions for using temperature control modules

- At power-on or power-off, a voltage or current may flow between output terminals momentarily. In this case, start the control after analog outputs become stable.

Precautions for using high-speed counter modules

- Do not install the control lines or communication cables together with the main circuit lines or power cables.
Keep a distance of 150mm or more between them.
Failure to do so may result in malfunction due to noise.

[Design Precautions]

CAUTION

Precautions for using positioning modules

- Note that when the reference axis speed is designated for interpolation operation, the speed of the partner axis (2nd axis, 3rd axis and 4th axis) may be larger than the set speed (larger than the speed limit value).

Precautions for using Ethernet interface modules and high speed data communication modules

- When changing the operating status of the CPU module (such as remote RUN/STOP) from the external device, select "Always wait for OPEN (Communication possible at STOP time)" for the "Initial timing" setting in the network parameter. The communication line will be closed when "Do not wait for OPEN (Communications impossible at STOP time)" is selected and the remote STOP is executed from the external device. Consequently, the CPU module cannot reopen the communication line, and the external device cannot execute the remote RUN.

Precautions for using MELSECNET/H network modules

- Always reset the CPU module after changing the parameters for the CPU module or the remote I/O module. If this is not done, data from before the change could cause malfunctioning.

[Installation Precautions]

CAUTION

- Use the programmable controller in an environment that meets the general specifications in this manual.
Failure to do so may result in electric shock, fire, malfunction, or damage to or deterioration of the product.
- To mount the module, while pressing the module mounting lever located in the lower part of the module, fully insert the module fixing projection(s) into the hole(s) in the base unit and press the module until it snaps into place.
Incorrect mounting may cause malfunction, failure or drop of the module.
When using the programmable controller in an environment of frequent vibrations, fix the module with a screw.
For a module with module fixing brackets, fix the module to the base unit with the brackets.
- Tighten the screws within the specified torque range.
Undertightening can cause drop of the screw, short circuit or malfunction.
Overtightening can damage the screw and/or module, resulting in drop, short circuit, or malfunction.
- When using an extension cable, connect it to the extension cable connector of the base unit securely.
Check the connection for looseness.
Poor contact may cause incorrect input or output.
- When using a memory card, SD card, or CompactFlash card, fully insert it into the memory card slot.
Check that it is inserted completely.
Poor contact may cause malfunction.
- Securely insert an extended SRAM cassette into the cassette connector of a CPU module. After insertion, close the cassette cover to prevent the cassette from coming off. Failure to do so may cause malfunction.
- Shut off the external power supply (all phases) used in the system before mounting or removing the module. Failure to do so may result in damage to the product.
A module can be replaced online (while power is on) on any MELSECNET/H remote I/O station or in the system where a CPU module supporting the online module change function is used.
Note that there are restrictions on the modules that can be replaced online, and each module has its predetermined replacement procedure.
For details, refer to the relevant sections in the QCPU User's Manual (Hardware Design, Maintenance and Inspection) and in the manual for the corresponding module.

[Installation Precautions]

CAUTION

- Keep in mind that there is a possibility that the unit is high temperature, during turning on electricity and immediately after power supply interception.
- Do not directly touch any conductive parts and electronic components of the module, memory card, SD memory card, or extended SRAM cassette. Doing so can cause malfunction or failure of the module.
- When using a Motion CPU module and modules designed for motion control, check that the combinations of these modules are correct before applying power.
The modules may be damaged if the combination is incorrect.
For details, refer to the user's manual for the Motion CPU module.

[Wiring Precautions]

WARNING

- Shut off the external power supply (all phases) used in the system before wiring. Failure to do so may result in electric shock or damage to the product.
- After installation and wiring, attach the included terminal cover to the module before turning it on for operation. Failure to do so may result in electric shock.

[Wiring Precautions]

CAUTION

- Individually ground the FG and LG terminals of the programmable controller with a ground resistance of 100Ω or less.
Failure to do so may result in electric shock or malfunction.
- Use applicable solderless terminals and tighten them within the specified torque range. If any spade solderless terminal is used, it may be disconnected when the terminal screw comes loose, resulting in failure.
- Check the rated voltage and terminal layout before wiring to the module, and connect the cables correctly. Connecting a power supply with a different voltage rating or incorrect wiring may cause a fire or failure.
- Connectors for external devices or coaxial cable connectors must be crimped or pressed with the tool specified by the manufacturer, or must be correctly soldered. Incomplete connections may cause short circuit, fire, or malfunction.
- Securely connect the connector to the module. Poor contact may cause malfunction.

[Wiring Precautions]

CAUTION

- Do not install the control lines or communication cables together with the main circuit lines or power cables.
Keep a distance of 100mm or more between them.
Failure to do so may result in malfunction due to noise.
- Place the cables in a duct or clamp them. If not, dangling cables may swing or inadvertently be pulled, resulting in damage to the module or cables or malfunction due to poor connection.
- Check the interface type and correctly connect the cable. Incorrect wiring (connecting the cable to an incorrect interface) may cause failure of the module and external device.
- Tighten the terminal screw within the specified torque range.
Undertightening can cause short circuit, fire, or malfunction.
Overtightening can damage the screw and/or module, resulting in drop, short circuit, or malfunction.
- Tighten the connector screws within the specified torque range.
Undertightening can cause short circuit, fire, or malfunction. Overtightening can damage the screw and/or module, resulting in drop, short circuit, fire, or malfunction.
- When disconnecting the cable from the module, do not pull the cable by the cable part. For a cable with connector, hold the connector by hand and pull it out. For the cable connected to the terminal block, loosen the terminal screw. Pulling the cable connected to the module may result in malfunction or damage to the module or cable.
- Check the interface type and correctly connect the cable. Incorrect wiring (connecting the cable to an incorrect interface) may cause failure of the module and external device.
- Prevent foreign matter such as dust or wire chips from entering the module. Such foreign matter can cause a fire, failure, or malfunction.
- A protective film is attached to the top of the module to prevent foreign matter, such as wire chips, from entering the module during wiring.
Do not remove the film during wiring.
Remove it for heat dissipation before system operation.
- Mitsubishi programmable controllers must be installed to control panels.
Connect the main power supply to the power supply module in the control panel through a relay terminal block. Wiring and replacement of a power supply module must be performed by qualified maintenance personnel with knowledge of protection against electric shock. (For wiring methods, refer to the QCPU User's Manual (Hardware Design, Maintenance and Inspection)).

[Wiring Precautions]

CAUTION

Precautions for using temperature input modules

- Keep a distance of 100mm or more between a thermocouple and the main circuit line or AC control lines. Also, keep the thermocouple away from a circuit that includes harmonics, such as a high-voltage circuit and a load circuit of an inverter. If not, the thermocouple is more likely to be affected by noise, surges, and induction.
- Do not place the module near a device that generates magnetic noise.

Precautions for using load cell input modules

- Shut off the external power supply (all phases) used in the system before mounting or removing the module. Failure to do so may apply an excessive voltage to the load cell, resulting in heat generation or damage of the load cell.

Precautions for using high-speed counter modules

- Do not install the control lines or communication cables together with the main circuit lines or power cables.
Keep a distance of 150mm or more between them.
Failure to do so may result in malfunction due to noise.

Precautions for using positioning modules with built-in counter function

- Do not install cables for connecting external I/O signals of the positioning module with built-in counter function and drive unit together with the main circuit cables, power cables, and/or the load cables for any other than programmable controllers or not bring them close to each other. Keep a distance of 100mm or more between them. Failure to do so may cause a malfunction due to noise, surge or induction.

Precautions for using CC-Link system master/local modules

- For the CC-Link system, use dedicated cables that are specified by the manufacturer. If any other cable is used, performance of the CC-Link system is not guaranteed. Also, the maximum overall cable length and the station-to-station cable length must meet those specified in the CC-Link System Master/Local Module User's Manual. If not, normal data communication is not guaranteed.

[Wiring Precautions]

CAUTION

Precautions for using CC-Link/LT master modules

- Use cables specified by CC-Link Partner Association for a CC-Link/LT system. If not, the performance of the CC-Link/LT system is not guaranteed. For the network wiring, follow the specifications described in CC-Link/LT Master Module User's Manual. If not, normal data transmission is not guaranteed.

Precautions for using FL-net (OPCN-2) interface modules

- Do not connect AUI cables when the programmable controllers on the station where the module is mounted and the FL-net (OPCN-2) system are powered ON.

[Startup and Maintenance Precautions]

WARNING

- Do not touch any terminal while power is on. Doing so will cause electric shock or malfunction.
- Correctly connect the battery connector. Do not charge, disassemble, heat, short-circuit, solder, or throw the battery into the fire. Also, do not expose it to liquid or strong shock. Doing so will cause the battery to produce heat, explode, ignite, or leak, resulting in injury and fire.
- Shut off the external power supply (all phases) used in the system before cleaning the module or retightening the terminal screws, connector screws, or module fixing screws. Failure to do so may result in electric shock or cause the module to fail or malfunction.

[Startup and Maintenance Precautions]

CAUTION

- When connecting a peripheral with the programmable controller CPU or connecting a personal computer with an intelligent function module to modify data of a running programmable controller, configure an interlock circuit in the sequence program to ensure that the entire system will always operate safely. For other forms of control (such as program modification, parameter change, forced output, or operating status change) of a running programmable controller, read the relevant manuals carefully and ensure that the operation is safe before proceeding.
Especially, when a remote programmable controller is controlled by an external device, immediate action cannot be taken if a problem occurs in the programmable controller due to a communication failure.
To prevent this, configure an interlock circuit in the sequence program, and determine corrective actions to be taken between the external device and CPU module in case of a communication failure.
- Do not disassemble or modify the modules.
Doing so may cause failure, malfunction, injury, or a fire.
- Use any radio communication device such as a cellular phone or PHS (Personal Handy-phone System) more than 25cm away in all directions from the programmable controller.
Failure to do so may cause malfunction.
- Shut off the external power supply (all phases) used in the system before mounting or removing the module. Failure to do so may cause the module to fail or malfunction.
A module can be replaced online (while power is on) on any MELSECNET/H remote I/O station or in the system where a CPU module supporting the online module change function is used.
Note that there are restrictions on the modules that can be replaced online, and each module has its predetermined replacement procedure.
For details, refer to the relevant sections in the QCPU User's Manual (Hardware Design, Maintenance and Inspection) and in the manual for the corresponding module.
- After the first use of the product, do not mount/remove the module to/from the base unit, and the terminal block to/from the module, and do not insert/remove the extended SRAM cassette to/from the CPU module more than 50 times (IEC 61131-2 compliant) respectively.
Exceeding the limit of 50 times may cause malfunction.

[Startup and Maintenance Precautions]

CAUTION

- After the first use of the product, do not insert/remove the SD memory card to/from the CPU module more than 500 times. Exceeding the limit may cause malfunction.
- Do not drop or apply shock to the battery to be installed in the module. Doing so may damage the battery, causing the battery fluid to leak inside the battery. If the battery is dropped or any shock is applied to it, dispose of it without using.
- Startup and maintenance of a control panel must be performed by qualified maintenance personnel with knowledge of protection against electric shock. Lock the control panel so that only qualified maintenance personnel can operate it.
- Before handling the module, touch a conducting object such as a grounded metal to discharge the static electricity from the human body. Failure to do so may cause the module to fail or malfunction.
- Use a clean and dry cloth to wipe off dirt on the module.

Precautions for using positioning modules

- Before starting test operation, set the parameter speed limit value to the slowest value, and make sure that operation can be stopped immediately if a hazardous state occurs.

[Disposal Precautions]

CAUTION

- When disposing of this product, treat it as industrial waste. When disposing of batteries, separate them from other wastes according to the local regulations. (For details of the Battery Directive in EU countries, refer to QCPU User's Manual (Hardware Design, Maintenance and Inspection).)

[Transportation Precautions]

CAUTION

- When transporting lithium batteries, follow the transportation regulations. (For details of the regulated models, refer to QCPU User's Manual (Hardware Design, Maintenance and Inspection).)
- The halogens (such as fluorine, chlorine, bromine, and iodine), which are contained in a fumigant used for disinfection and pest control of wood packaging materials, may cause failure of the product. Prevent the entry of fumigant residues into the product or consider other methods (such as heat treatment) instead of fumigation. The disinfection and pest control measures must be applied to unprocessed raw wood.

● PRÉCAUTIONS DE SÉCURITÉ ●

(Lire ces précautions avant toute utilisation du produit.)

Avant d'utiliser ce produit, lire attentivement ce manuel ainsi que les manuels auxquels il renvoie, et toujours considérer la sécurité comme de la plus haute importance en manipulant le produit correctement. Si les produits sont utilisés autrement que ne le prescrivent leurs fabricants, il se peut leur fonctions de protection ne soient pas efficaces.

Dans ce manuel, les précautions de sécurité sont classées en deux niveaux, à savoir : " ⚠ AVERTISSEMENT " et " ⚠ ATTENTION ".

⚠ AVERTISSEMENT

Attire l'attention sur le fait qu'une négligence peut créer une situation de danger avec risque de mort ou de blessures graves.

⚠ ATTENTION

Attire l'attention sur le fait qu'une négligence peut créer une situation de danger avec risque de blessures légères ou de gravité moyennes ou risque de dégâts matériels.

Dans certaines circonstances, le non-respect d'une précaution de sécurité introduite sous le titre " ⚠ ATTENTION " peut avoir des conséquences graves. Les précautions de ces deux niveaux doivent être observées dans leur intégralité car elles ont trait à la sécurité des personnes et aussi du système.

Veiller à ce que les utilisateurs finaux lisent ce manuel qui doit être conservé soigneusement à portée de main pour s'y référer autant que de besoin.

! AVERTISSEMENT

- Configurer des circuits de sécurité extérieurs à l'automate programmable pour garantir la sécurité du système dans son ensemble à la survenance d'une anomalie dans l'alimentation externe comme dans l'automate programmable. Faute de quoi, une instruction de sortie incorrecte ou un dysfonctionnement pourrait être à l'origine d'un accident.

- (1) Configurer des circuits de sécurité externes, comme un circuit d'arrêt d'urgence, un circuit de protection et les circuits de verrouillage de sécurité pour l'opération d'inversion de marche avant/arrière et de positionnement en limite haute/basse.
- (2) L'automate programmable suspend sa marche à la détection d'un des états suivants, l'état de sortie du système étant alors comme indiqué ci-dessous.

	Module de série Q	Module de série AnS/A
La protection contre surintensité ou surtension du module d'alimentation a déclenché.	Toutes les sorties sont mises hors service.	Toutes les sorties sont mises hors service.
Le module CPU détecte une erreur, telle qu'une erreur d'horloge de surveillance détectée par la fonction d'autodiagnostic.	Toutes les sorties sont maintenues ou mises hors service en fonction du paramétrage.	Toutes les sorties sont mises hors service.

Il se peut toutefois que toutes les sorties restent actives si l'erreur se produit dans un organe où le module CPU ne peut pas détecter les erreurs, comme par exemple un organe de commande d'entrée/sortie. Pour garantir la sécurité en exploitation dans un telle éventualité, il faut donc prévoir un mécanisme de sécurité ou un circuit de mise en sécurité à l'extérieur de l'automate programmable. On trouvera un exemple de circuit de mise en sécurité à la rubrique "EXIGENCES GÉNÉRALES DU POINT DE VUE DE LA SÉCURITÉ" du présent manuel.

- (3) Une panne de relais ou de transistor dans un module de sortie pourrait activer ou interrompre certaines sortie. Configurer un circuit de surveillance externe pour le suivi des signaux de sortie susceptibles de provoquer un accident grave.
- Dans un circuit de sortie, si le courant de charge excède la valeur nominale ou si une surintensité causée par un court-circuit à la charge persiste longtemps, il peut en résulter un dégagement de fumée avec départ de feu. Pour éviter cela, il faut configurer un circuit de sécurité, avec un fusible par exemple.
 - Configurer le circuit de façon à allumer d'abord l'automate programmable avant l'alimentation externe.
Si on commence par brancher l'alimentation externe, ceci peut être une cause d'accident en cas de sortie incorrecte ou autre dysfonctionnement.

 AVERTISSEMENT

- *Quant à l'état opérationnel de chacune des stations en cas de problème de communication, voir les manuels correspondants pour le réseau. Une sortie erronée ou un dysfonctionnement suite à une erreur de communication peuvent être à l'origine d'un accident.*
- *Si on raccorde un périphérique à la CPU de l'automate programmable ou si on raccorde un ordinateur personnel à un module fonctionnel intelligent pour modifier les données d'un automate programmable en marche, il faut constituer un circuit de verrouillage dans le programme séquentiel pour garantir la sécurité de fonctionnement de l'ensemble du système.
Pour les autres types d'intervention (comme une modification de programme, un changement de paramètres, une sortie forcée ou un changement d'état fonctionnel) sur un automate programmable en marche, commencer par lire attentivement les manuels correspondants pour travailler ensuite en toute sécurité.
En particulier, lorsqu'un automate programmable distant est commandé à partir d'un dispositif externe, il faut tenir compte du fait qu'aucune action ne sera possible s'il y a un problème de communication avec l'automate programmable.
Pour éviter cela, constituer un circuit de verrouillage dans le programme séquentiel, et prévoir les mesures correctives à prendre entre le dispositif externe et le module CPU en cas de problème de communication.*
- *N'introduire aucune donnée dans la zone interdite à l'écriture de la mémoire-tampon du module fonctionnel intelligent. En outre, comme signal de sortie du module CPU vers le module fonctionnel intelligent, il ne faut utiliser aucun des signaux dont l'usage est interdit ("use prohibited"). Faute de quoi, il y aura des dysfonctionnements dans le système de l'automate programmable. À propos des zones mémoire interdites à l'écriture et des signaux dont l'usage est interdit, voir le manuel de l'utilisateur de chacun des modules fonctionnels intelligents.*
- *Le débranchement d'un câble de communication peut entraîner une instabilité de tout le réseau avec des problèmes de communication sur de multiples stations. Prévoir dans le programme un circuit de verrouillage permettant de garantir la sécurité de l'ensemble du système en cas de problème de communication. Faute de quoi, une instruction de sortie incorrecte ou un dysfonctionnement pourrait être à l'origine d'un accident.*

[Précautions lors de la conception]

AVERTISSEMENT

- *Prendre les mesures appropriées pour maintenir la sécurité sur le système de l'automate programmable en cas d'accès non autorisé d'un dispositif externe via le réseau. De plus, pour maintenir la sécurité sur le système de l'automate programmable en cas d'accès non autorisé d'un dispositif externe via Internet, prendre des mesures adéquates du genre coupe-feu.*

Précautions d'utilisation des modules de positionnement

- *Configurer des circuits de sécurité extérieurs à l'automate programmable pour garantir la sécurité du système dans son ensemble à la survenance d'une anomalie dans l'alimentation externe comme dans l'automate programmable. Faute de quoi, une instruction de sortie incorrecte ou un dysfonctionnement pourrait être à l'origine d'un accident.*
 - (1) *Constituer un circuit d'arrêt d'urgence et un circuit de verrouillage, avec par exemple limite haute/basse dans la commande de positionnement, pour éviter tout dégât mécanique à l'extérieur de l'automate programmable.*
 - (2) *L'OPR machine (retour au point origine) se commande par deux sortes de données : sens vers OPR et vitesse vers OPR. La décélération commence à l'apparition du signal de surveillance d'approche. Si l'indication du sens vers l'OPR est erronée, la commande de mouvement continue sans décélération. Pour éviter l'endommagement de la machine dans une telle éventualité, constituer un circuit de verrouillage extérieur à l'automate programmable.*
 - (3) *Quand le module détecte une erreur, il y a arrêt avec décélération. Vérifier que les données d'OPR et les données de positionnement restent dans la plage de valeurs paramétrables.*

Précautions d'utilisation des modules d'interface Ethernet

- *Pour éviter qu'un e-mail malveillant n'entraîne des dysfonctionnement du système d'automate programmable, prendre des mesures préventives (antivirus, etc.) sur le serveur d'e-mail de ce module.*

Précautions d'utilisation des modules de serveur Web

- *Quand on utilise la fonction e-mail, il faut tenir compte d'un possible décalage de temps pour l'envoi d'un e-mail du fait de l'état du serveur émetteur, du canal de transmission et du serveur et/ou dispositif de réception. Constituer un circuit de notification d'erreur avec témoin lumineux ou bruiteur pour garantir la sécurité du système d'automate programmable.*

[Précautions lors de la conception]

AVERTISSEMENT

Précautions d'utilisation des modules réseau avec contrôleur CC-Link IE.

- L'émetteur et le récepteur optiques du module de tête utilisent des diodes laser (classe 1 selon IEC 60825-1). Ne pas observer directement le rayon laser à l'œil nu. Il y aurait risque de lésion oculaire.

Précautions d'utilisation des modules réseau MELSECNET/H

- En cas de problème de communication dans le réseau, l'état de la station à l'origine de l'erreur sera comme suit. Vérifier les infos d'état de communication et constituer un circuit de verrouillage dans le programme séquentiel pour garantir la sécurité de fonctionnement de l'ensemble du système. Faute de quoi, une instruction de sortie incorrecte ou un dysfonctionnement pourrait être à l'origine d'un accident.
 - (1) La station maîtresse distante retiendra les données antérieures à l'erreur de communication.
 - (2) La station I/O distante interrompt toutes les sorties. Le module de sortie de la station I/O distante peut annuler ou maintenir l'état de sortie du moment de la survenance de l'erreur selon le paramétrage du module I/O distant. Par défaut, le paramétrage est "clear" (annuler) et le module de sortie interrompt toutes les sorties à la survenance d'une erreur. Si la sécurité du système n'est pas compromise par le maintien des sorties, on peut choisir le paramètre "Hold" (maintien).

Précautions d'utilisation des modules maîtres/locaux d'un système CC-Link

- Au paramétrage de la réactualisation automatique, sélectionner le dispositif Y comme dispositif de réactualisation (RY) de sortie distante. Si on sélectionne un dispositif autre que Y, comme M ou L, le module CPU maintient l'état antérieur du dispositif même après le passage à l'état STOP. À propos de l'interruption de la liaison de données, voir le Manuel de l'utilisateur des modules maître/local du système CC-Link.

Précautions d'utilisation des modules de communication en série

- Quand on utilise la fonction de notification, il peut arriver que le récepteur du téléavertisseur ne puisse être contacté en raison d'un état de transmission de fréquence provenant de l'environnement d'installation du système, ou d'une erreur du côté du récepteur. Constituer un circuit de notification d'erreur avec témoin lumineux ou bruiteur pour garantir la sécurité du système d'automate programmable.

 AVERTISSEMENT

Précautions d'utilisation des modules d'interface FL-net (OPCN-2)

- *Voir, dans le manuel de l'utilisateur des modules d'interface FL-net (OPCN-2), les informations concernant le fonctionnement de chacun des nœuds lorsque la transmission cyclique produit une erreur de communication en mode FL-net (OPCN-2). Une sortie erronée ou un dysfonctionnement suite à une erreur de communication peuvent être à l'origine d'un accident.*

Précautions d'utilisation des modules maîtres AS-i

- *À la survenance d'une erreur de communication dans le système AS-i, l'entrée est mise OFF par l'esclave où est apparu l'erreur de communication. La sortie vers l'esclave en état d'erreur de communication peut être maintenue ou annulée, ce qui dépend des spécifications de l'esclave. La confirmation de l'erreur de communication dans le système AS-i peut se faire par le listage des esclaves actifs en mémoire-tampon (LAS) (15H à 18H) ou par l'erreur de configuration des signaux d'entrée (X4). Sur la base de l'information ci-dessus, constituer un circuit de verrouillage dans le programme séquentiel pour permettre la libre activation du système. Faute de quoi, une instruction de sortie incorrecte ou un dysfonctionnement pourrait être à l'origine d'un accident.*
- *Selon la nature de la défaillance du module, l'entrée/sortie passe à l'état ON ou OFF. Prévoir un circuit de surveillances des signaux d'entrée/sortie susceptibles d'être à l'origine d'accidents majeurs.*

 **AVERTISSEMENT**

Précautions d'utilisation des modules de communication intelligents

- *Pour le raccordement d'un dispositif périphérique au module CPU ou pour prendre le contrôle d'un automate programmable utilisé en programme BASIC, constituer un circuit de verrouillage séquentiel en vue de garantir la sécurité de fonctionnement de l'ensemble du système en tous temps. Avant toute autre intervention de commande (changement de programme, changement d'état opérationnel (commande d'état)) sur l'automate programmable en marche, lire attentivement le Manuel de l'Utilisateur des modules de communication intelligents correspondants pour pouvoir opérer en toute sécurité. En particulier, lorsqu'un automate programmable distant est commandé à partir d'un dispositif externe, il faut tenir compte du fait qu'aucune action ne sera possible s'il y a un problème de communication avec l'automate programmable. Pour éviter cela, constituer un circuit de verrouillage dans le programme séquentiel, et prévoir les mesures correctives à prendre entre le dispositif externe et le module CPU en cas de problème de communication.*

 **AVERTISSEMENT**

Précautions d'utilisation des produits en environnement de Class I, Division 2

- *Les produits marqués Cl.I, DIV.2 sur la plaque signalétique peuvent être utilisés en Class I, Division 2, local dangereux de groupe A, B, C et D, ou uniquement en local non dangereux. Ce logo indique que le produit est homologué pour utilisation en environnement de Class I, Division 2 où, dans des circonstances anormales, il peut y avoir présence de gaz, vapeurs ou liquides inflammables. Si le produit est utilisé en environnement de Class I, Division 2, observer les précautions suivantes pour réduire le risque d'explosion.*
 - *Cet appareil est de type ouvert et il doit être installé dans une enceinte appropriée à l'environnement et ne pouvant être ouverte qu'au moyen d'une clé ou d'un outil.*
 - *Avertissement - Danger d'explosion - Toute substitution de composant peut compromettre l'aptitude à l'utilisation en Class I, Division 2.*
 - *Avertissement - Danger d'explosion - Ne pas déconnecter l'équipement quand le circuit est sous tension, ni avant de d'être assuré de l'absence d'atmosphère inflammable.*
 - *Ne pas ouvrir le couvercle du module CPU et ne pas retirer la batterie avant d'avoir vérifié que l'atmosphère est sans danger.*
 - *Tous les modules MELSEC-Q (autres que les modules de base) doivent être connectés sur un module de base uniquement.*
 - *Quand l'équipement est sous tension, ne pas connecter ou déconnecter un câble au/du connecteur RS-232 du module CPU et du module E/S MELSECNET/H sans avoir vérifié que l'atmosphère est sans danger. Le connecteur RS-232 est destiné uniquement à la maintenance, et il ne doit pas resté connecté en permanence.*
 - *Connecter un câble de raccordement RS-232 (QC30R2) de fabrication Mitsubishi au connecteur RS-232 du module CPU. Si le câble doit resté raccordé en permanence, le fixer au moyen du dispositif anti-déconnexion pour connecteur RS-232 (Q6HLD-R2) afin d'éviter toute déconnexion accidentelle.*

[Précautions lors de la conception]

ATTENTION

- *Ne pas entremêler les lignes de commandes ou câbles de communication avec les lignes des circuits principaux ou les câbles d'alimentation. Les installer en maintenant entre eux une distance minimum de 100 mm. Faute de quoi, il y a risque de dysfonctionnement par un bruit.*
- *Lorsque le module de sortie commande un dispositif comme une lampe, un réchauffeur ou une électrovanne, un fort courant (jusqu'à 10 fois l'intensité normale) traverse la sortie quand celle-ci passe de OFF à ON. Prendre les mesures indispensables, comme le remplacement du module par un autre ayant une capacité de courant suffisante.*
- *À la mise sous tension ou à la réinitialisation du module CPU, le temps nécessaire à l'entrée en état RUN dépend de la configuration du système, du paramétrage et/ou de la taille du programme. Concevoir les circuits de manière que tout le système fonctionne en sécurité, indépendamment de ce temps.*
- *Pendant l'enregistrement des réglages, ne pas couper l'alimentation des stations où il y a un module connecté. Ne pas procéder non plus à une réinitialisation du module CPU. Cela pourrait conduire à une instabilité des données en ROM-flash ou en carte-mémoire flash, ce qui obligerait à refaire les réglages et leur enregistrement. En outre cela pour faire tomber le module en panne ou entraîner des dysfonctionnements.*

[Précautions lors de la conception]

ATTENTION

Précautions d'utilisation des modules convertisseurs numériques-analogiques

- *À la mise sous tension ou hors tension, il peut y avoir une tension ou un courant transitoire entre les bornes de sortie. Dans ce cas, ne faire démarrer la régulation qu'après la stabilisation des sorties analogiques.*

Précautions d'utilisation des modules de régulation de température

- *À la mise sous tension ou hors tension, il peut y avoir une tension ou un courant transitoire entre les bornes de sortie. Dans ce cas, ne faire démarrer la régulation qu'après la stabilisation des sorties analogiques.*

Précautions d'utilisation des modules compteurs haute-vitesse

- *Ne pas entremêler les lignes de commandes ou câbles de communication avec les lignes des circuits principaux ou les câbles d'alimentation. Les installer en maintenant entre eux une distance minimum de 150mm. Faute de quoi, il y a risque de dysfonctionnement par un bruit.*

Précautions d'utilisation des modules de positionnement

- *On remarquera que, quand une vitesse d'axe de référence est attribuée pour une opération d'interpolation, la vitesse des axes partenaires (2ème axe, 3ème axe et 4ème axe) peut devenir plus grande que la vitesse de consigne (supérieure à la valeur limite de vitesse).*

Précautions d'utilisation des modules d'interface Ethernet et des modules de communication de données à grande vitesse

- *Pour changer l'état opérationnel du module CPU (par exemple un changement RUN/STOP distant) à partir d'un dispositif externe, choisir dans le paramétrage réseau l'option "Always wait for OPEN (Communication possible at STOP time)" à la rubrique "Initial timing". La ligne de communication sera coupée si on a choisi l'option "Do not wait for OPEN (Communications impossible at STOP time)" quand on exécute un STOP distant à partir du dispositif externe. Par suite, le module CPU ne pourra pas réouvrir la ligne de communication et le dispositif externe ne pourra pas exécuter le RUN distant.*

Précautions d'utilisation des modules réseau MELSECNET/H

- *Toujours effectuer une réinitialisation du module CPU si on a changé des paramètres du module CPU ou du module d'entrée/sortie distant. Faute de quoi, les données d'avant le changement pourraient causer des dysfonctionnements.*

[Précautions d'installation]

ATTENTION

- *Utiliser l'automate programmable dans un environnement en conformité avec les spécifications générales que présente ce manuel.
Faute de quoi, il a risque d'électrocution, de départ de feu, de dysfonctionnement, d'endommagement ou de détérioration du produit.*
- *Pour fixer le module à sa place, tout en appuyant sur le levier de fixation qui se trouve à la partie inférieure du module, engager le(s) ergot(s) de fixation du module à fond dans le(s) trou(s) du socle et appuyer sur le module jusqu'à encliquètement.
Mal fixé en place, le module risque de se détacher, de ne pas fonctionner ou de présenter des dysfonctionnements.
Si l'automate programmable est installé dans un environnement exposé aux vibrations, le module doit être immobilisé par une vis de blocage.
Si le module est équipé de ferrures de fixation, le fixer sur le socle au moyen des ferrures.*
- *Serrer les vis dans les limites du couple serrage prescrit.
Si les vis sont insuffisamment serrées, le module risque de tomber et il peut y avoir des court-circuits ou des dysfonctionnements.
Un serrage excessif peut endommager les vis et/ou le module, avec aussi un risque de chute, de court-circuits et de dysfonctionnements.*
- *Si on utilise un câble de rallonge, le raccorder fermement sur le connecteur pour câble de rallonge sur l'unité de base.
Vérifier que les connexions ne sont pas desserrées.
Un mauvais contact peut être à l'origine d'une entrée ou sortie erronée.*
- *Si on utilise une carte-mémoire, une carte SD ou une carte CompactFlash, introduire la carte bien à fond dans le panier à l'emplacement pour carte-mémoire.
Vérifier que la carte a été poussée bien à fond dans le logement.
Tout mauvais contact peut être source de dysfonctionnements.*
- *Introduire fermement la cassette rallonge SRAM dans le connecteur de cassette du module CPU. Après insertion, fermer le couvercle de la cassette pour éviter que la cassette ne se détache. Le non-respect de cette précaution expose à des dysfonctionnements.*

[Précautions d'installation]

ATTENTION

- *Avant de mettre en place ou de retirer le module, couper l'alimentation externe utilisée par le système (couper toutes les phases). Faute quoi, le produit risquerait d'être endommagé.
Sur toutes les stations d'entrée/sortie distantes MELSECNET/H, il est possible de procéder au remplacement d'un module en ligne (alimentation sous tension) sous réserve que le module CPU supporte la fonction de changement de modules en ligne.
On remarquera qu'il existe des restrictions quant aux modules pouvant être remplacés en ligne et que, pour chaque modèle, il y a un mode opératoire à respecter pour le remplacement.
Pour le détail, se reporter aux sections correspondantes du Manuel de l'utilisateur QCPU (conception du matériel, maintenance et inspection) et au manuel du module en question.*
- *Ne jamais oublier que la température de l'unité peut être élevée, ce qui est le cas quand elle est sous tension mais aussi lorsqu'elle vient d'être mise hors tension.*
- *Éviter tout contact direct avec les parties conductrices et les composants électroniques du module, de la carte-mémoire, de la carte-mémoire SD, ou de la cassette d'extension SRAM. Une manipulation incorrecte peut être à l'origine de dysfonctionnements ou de pannes du module.*
- *Quand on utilise un module CPU de mouvements ou des modules conçus pour la régulation des mouvements, s'assurer avant la mise sous tension que les modules combinés sont compatibles entre eux.
Si on combine des modules non compatibles, ceux-ci risquent d'être endommagés.
Pour le détail, voir le manuel de l'utilisateur Module CPU pour mouvements.*

[Précautions de câblage]

AVERTISSEMENT

- *Avant le câblage, couper l'alimentation externe du système (sur toutes les phases). Faute de quoi, il y a risque d'électrocution et d'endommagement du produit.*
- *Après installation et câblage, refermer les couvre-bornes avant la mise sous tension et la mise en marche. Faute de quoi, il y a risque d'électrocution.*

[Précautions de câblage]

ATTENTION

- *Mettre à la terre individuellement les bornes FG et LG de l'automate programmable avec une résistance de terre inférieure à 100Ω. Faute de quoi, il y a risque d'électrocution et de dysfonctionnement.*
- *Utiliser des bornes sans soudure de type approprié et serrer au couple de serrage prescrit. Si on utilise des bornes sans soudure de type embrochable, il y a risque de déconnexion et de panne au cas où une vis de borne se desserrerait.*
- *Vérifier la tension nominale et l'affectation des bornes avant le câblage du module et raccorder les câbles correctement. Le raccordement d'une alimentation d'une tension autre que la tension nominale ou une erreur de câblage peut être à l'origine d'un départ de feu ou d'une panne.*
- *Les connecteurs pour dispositifs externes ou câbles coaxiaux doivent être sertis en utilisant l'outil prescrit par le fabricant ou, à défaut, ils seront correctement brasés. Des connexions imparfaites peuvent être à l'origine de court-circuits, départs de feu ou dysfonctionnements.*
- *Raccorder fermement le connecteur sur le module. Tout mauvais contact peut être source de dysfonctionnements.*
- *Ne pas entremêler les lignes de commandes ou câbles de communication avec les lignes des circuits principaux ou les câbles d'alimentation. Les installer en maintenant entre eux une distance minimum de 100 mm. Faute de quoi, il y a risque de dysfonctionnement par un bruit.*
- *Les câbles doivent être placés dans un conduit de câbles ou doivent être attachés. Faute de quoi, le ballotement ou le déplacement des câbles pourrait endommager le module ou les câbles et être à l'origine de dysfonctionnements par mauvais contact.*

 **ATTENTION**

- *Vérifier le type d'interface et raccorder les câbles correctement. Un câblage incorrect (avec raccordement d'un câble à une interface incorrect) peut entraîner une panne du module ou du dispositif externe.*
- *Serrer les vis de borne dans les limites du couple de serrage prescrit. Si les vis sont insuffisamment serrées, il y a risque de court-circuits, départ de feu ou dysfonctionnement.
Un serrage excessif peut endommager les vis et/ou le module, avec aussi un risque de chute, de court-circuits et de dysfonctionnements.*
- *Serrer les vis de connecteur dans les limites du couple de serrage prescrit. Si les vis sont insuffisamment serrées, il y a risque de court-circuits, départ de feu ou dysfonctionnement. Un serrage excessif peut endommager les vis et/ou le module, avec aussi un risque de chute, de court-circuits et de dysfonctionnements.*
- *Pour débrancher le câble du module, ne tirer directement sur le câble proprement dit. Si le câble a un connecteur, saisir le connecteur au main et débrancher en tirant par le connecteur. Pour un câble raccordé sur une plaque à bornes, desserrer la vis de la borne. Tirer sur un câble raccordé au module peut endommager le câble ou le module et être à l'origine de dysfonctionnements.*
- *Vérifier le type d'interface et raccorder les câbles correctement. Un câblage incorrect (avec raccordement d'un câble à une interface incorrect) peut entraîner une panne du module ou du dispositif externe.*
- *Veiller à ne pas laisser la poussière, les copeaux métalliques ou d'autres corps étrangers pénétrer dans le module.
Tout corps étranger peut être à l'origine d'un départ de feu, d'une panne ou d'un dysfonctionnement.*
- *Le haut du module est recouvert d'un film protecteur pour éviter toute pénétration de corps étrangers comme des copeaux métalliques pendant le câblage du module.
Ne pas retirer le film protecteur avant de terminer le câblage.
Il doit cependant être retiré avant la mise en service du système pour une meilleure dispersion de la chaleur.*

[Précautions de câblage]

ATTENTION

- *Les automates programmable Mitsubishi doivent être installés en tableau ou armoire de commande. Raccorder l'alimentation principale au module d'alimentation dans le tableau de commande sur une plaque à bornes avec relais. Le câblage et le remplacement d'un module d'alimentation doivent être effectués par un personnel de maintenance qualifié formé à la protection contre les chocs électriques. (Pour la méthode de câblage, se reporter au manuel de l'utilisateur QCPU (Conception du matériel, maintenance et inspection)).*

Précautions d'utilisation des modules d'entrée de température

- *Maintenir une distance d'au moins 100mm entre un thermocouple et les lignes de circuit principal et de commande en courant alternatif. De plus, veiller à ce que les thermocouples soient à bonne distance des circuits générateurs d'harmoniques, tels qu'un circuit haute-tension ou le circuit de charge d'un onduleur. Faute de quoi, les thermocouples sont affectés par les phénomènes de bruit, d'impulsion ou d'induction.*
- *Ne pas placer le module à proximité d'un dispositif générateur de bruits magnétiques.*

Précautions d'utilisation des modules d'entrée de la cellule de charge

- *Avant de mettre en place ou de retirer le module, couper l'alimentation externe utilisée par le système (couper toutes les phases). Faute de quoi, la surchauffe de la cellule de charge exposée à une tension excessive peut être à l'origine d'une panne.*

Précautions d'utilisation des modules compteurs haute-vitesse

- *Ne pas entremêler les lignes de commandes ou câbles de communication avec les lignes des circuits principaux ou les câbles d'alimentation. Les installer en maintenant entre eux une distance minimum de 150mm. Faute de quoi, il y a risque de dysfonctionnement par un bruit.*

[Précautions de câblage]

ATTENTION

Précautions d'utilisation des modules de positionnement avec fonction de comptage incorporée

- *Ne pas installer les câbles de raccordement des signaux d'entrée/sortie externes d'un module de positionnement avec fonction de comptage incorporée et les câbles des unités d'entraînement au voisinage des câbles des circuits principaux, des câbles d'alimentation et/ou de tous câbles de charge autres que ceux des automates programmables. Les installer en maintenant entre eux une distance minimum de 100mm. Faute de quoi, des phénomènes de bruit, d'impulsion ou d'induction peuvent entraîner des dysfonctionnements.*

Précautions d'utilisation des modules maîtres/locaux d'un système CC-Link

- *Pour le système CC-Link, utiliser les câbles dédiés préconisés par le fabricant. Avec tout autre type de câble, les performances ne peuvent être garanties. De plus, la longueur totale de câbles et la longueur des câbles de station à station doivent être en conformité avec les prescriptions du Manuel de l'utilisateur des modules maîtres/locaux pour système CC-Link. Sinon, la communication normales des données ne peut être garantie.*

Précautions d'utilisation des modules maîtres CC-Link/LT

- *Pour tout système CC-Link, utiliser les câbles préconisés par la CC-Link Partner Faute de quoi, les performances du système CC-Link/LT ne peuvent être garanties. Pour le câblage du réseau, appliquer les spécifications contenues dans le Manuel de l'utilisateur des modules maîtres CC-Link/LT. Sinon, la transmission normale des données ne peut être garantie.*

Précautions d'utilisation des modules d'interface FL-net (OPCN-2)

- *Ne pas raccorder les câbles AUI quand les automates programmables de la station où on installe le module et le système FL-net (OPCN-2) sont sous tension.*

[Précautions de mise en service et de maintenance]

AVERTISSEMENT

- *Ne toucher à aucun des bornes quand le système est sous tension. Faute de quoi, il y a risque d'électrocutions et de dysfonctionnements.*
- *Raccorder correctement le connecteur des piles. Les piles ne doivent pas être rechargées, démontées, court-circuitées ou soudées. Elles ne doivent pas non plus être jetées au feu. De plus, ne pas les exposer à des liquides ou à des chocs violents.*
Les piles ainsi maltraitées risqueraient de surchauffer, d'éclater, de prendre feu ou de fuir et pourraient être à l'origine de blessures ou d'un départ de feu.
- *Couper l'alimentation externe utilisée pour le système (sur toutes les phases) avant de procéder au nettoyage du module ou au resserrage des vis de bornes des vis de connecteur ou des vis de fixation du module. Faute de quoi, il y a risque d'électrocution et le module risque de tomber en panne ou de mal fonctionner.*

[Précautions de mise en service et de maintenance]

ATTENTION

- *Si on raccorde un périphérique à la CPU de l'automate programmable ou si on raccorde un ordinateur personnel à un module fonctionnel intelligent pour modifier les données d'un automate programmable en marche, il faut constituer un circuit de verrouillage dans le programme séquentiel pour garantir la sécurité de fonctionnement de l'ensemble du système.*
Pour les autres types d'intervention (comme une modification de programme, un changement de paramètres, une sortie forcée ou un changement d'état fonctionnel) sur un automate programmable en marche, commencer par lire attentivement les manuels correspondants pour travailler ensuite en toute sécurité.
En particulier, lorsqu'un automate programmable distant est commandé à partir d'un dispositif externe, il faut tenir compte du fait qu'aucune action ne sera possible s'il y a un problème de communication avec l'automate programmable.
Pour éviter cela, constituer un circuit de verrouillage dans le programme séquentiel, et prévoir les mesures correctives à prendre entre le dispositif externe et le module CPU en cas de problème de communication.
- *Ne pas démonter ni modifier les modules.*
Cela pourrait entraîner des pannes ou dysfonctionnements et être à l'origine de blessures ou de départs de feu.

 **ATTENTION**

- *Tout type d'appareil de communication radio, y compris les téléphones portables et les appareils PHS (Personal handy-phone system), doit être tenus éloignés de plus de 25cm de l'automate programmable, dans tous les sens.
Le non-respect de cette précaution expose à des dysfonctionnements.*
- *Avant de mettre en place ou de retirer le module, couper l'alimentation externe utilisée par le système (couper toutes les phases). Le non-respect de cette précaution peut être à l'origine de pannes ou de dysfonctionnements du module.
Sur toutes les stations d'entrée/sortie distantes MELSECNET/H, il est possible de procéder au remplacement d'un module en ligne (alimentation sous tension) sous réserve que le module CPU supporte la fonction de changement de modules en ligne.
On remarquera qu'il existe des restrictions quant aux modules pouvant être remplacés en ligne et que, pour chaque modèle, il y a un mode opératoire à respecter pour le remplacement.
Pour le détail, se reporter aux sections correspondantes du Manuel de l'utilisateur QCPU (conception du matériel, maintenance et inspection) et au manuel du module en question.*
- *Après la mise en service du produit, le nombre maximum admissible d'insertion/retrait du module sur son socle ou du bornier sur le module ou encore d'une cassette d'extension SRAM sur le module CPU est limité à respectivement 50 (en conformité avec la norme IEC 61131-2).
Dépasser ce nombre maximum de 50 opérations d'insertion/retrait peut être à l'origine de dysfonctionnements.*
- *Après la mise en service du produit, le nombre maximum admissible d'insertion/retrait de la carte-mémoire SD sur le module CPU est de 500. Le dépassement de cette limite peut être à l'origine de dysfonctionnements.*
- *Ne pas faire tomber ou soumettre à de forts chocs les piles à installer dans les modules. Cela pourrait endommager les piles, avec risque de fuite du liquide à l'intérieur des piles.
Toute pile qu'on a laissé tomber ou qui a subi un choc violent doit être jetée avant usage.*
- *La mise en service et la maintenance des tableaux de commande doivent être effectuées par un personnel de maintenance qualifié et formé à la protection contre les chocs électriques. Les tableaux de commande doivent être fermés à clef pour n'être accessibles qu'à un personnel de maintenance qualifié.*

[Précautions de mise en service et de maintenance]

ATTENTION

- Avant de manipuler un module, se débarrasser de la charge électrostatique qu'accumule le corps humain en touchant un objet conducteur approprié. Le non-respect de cette précaution peut être à l'origine de pannes ou de dysfonctionnements du module.
- Eliminer les impuretés en essuyant le module avec un chiffon propre et sec.

Précautions d'utilisation des modules de positionnement

- Avant la mise en marche d'essais, paramétrer les valeurs limites de vitesse au plus bas et vérifier que la marche pourra être immédiatement interrompue en cas de danger.

[Précautions de mise au rebut]

ATTENTION

- Lors de sa mise au rebut, ce produit doit être traité comme un déchet industriel. Les piles ou batteries doivent être mises au rebut séparément des autres déchets et conformément à la réglementation locale. Pour le détail des directives sur les piles et batteries dans les pays de l'Union Européenne, voir le Manuel de l'utilisateur QCPU (Conception du matériel, maintenance et inspection).

[Précautions de transport]

ATTENTION

- Pour le transport des piles au lithium, respecter la réglementation afférente à ce transport. (Pour le détail des modèles soumis à la réglementation, voir le Manuel de l'utilisateur QCPU (Conception du matériel, maintenance et inspection)).
- Les halogènes (comme le fluore, le chlore, le brome ou l'iode) contenus dans certains fumigènes de désinfection et de traitement antiparasite des emballage en bois peuvent de détérioration du produit. Protéger le produit contre la pénétration des résidus de fumigènes ou envisager d'autres méthodes de traitement que la fumigation (traitement thermique par exemple). Une désinfection et un traitement antiparasite doivent être appliqués sur le bois brut avant façonnage.

● CONDITIONS OF USE FOR THE PRODUCT ●

- (1) Mitsubishi programmable controller ("the PRODUCT") shall be used in conditions;
- i) where any problem, fault or failure occurring in the PRODUCT, if any, shall not lead to any major or serious accident; and
 - ii) where the backup and fail-safe function are systematically or automatically provided outside of the PRODUCT for the case of any problem, fault or failure occurring in the PRODUCT.
- (2) The PRODUCT has been designed and manufactured for the purpose of being used in general industries.

MITSUBISHI SHALL HAVE NO RESPONSIBILITY OR LIABILITY (INCLUDING, BUT NOT LIMITED TO ANY AND ALL RESPONSIBILITY OR LIABILITY BASED ON CONTRACT, WARRANTY, TORT, PRODUCT LIABILITY) FOR ANY INJURY OR DEATH TO PERSONS OR LOSS OR DAMAGE TO PROPERTY CAUSED BY the PRODUCT THAT ARE OPERATED OR USED IN APPLICATION NOT INTENDED OR EXCLUDED BY INSTRUCTIONS, PRECAUTIONS, OR WARNING CONTAINED IN MITSUBISHI'S USER, INSTRUCTION AND/OR SAFETY MANUALS, TECHNICAL BULLETINS AND GUIDELINES FOR the PRODUCT.

("Prohibited Application")

Prohibited Applications include, but not limited to, the use of the PRODUCT in;

- Nuclear Power Plants and any other power plants operated by Power companies, and/or any other cases in which the public could be affected if any problem or fault occurs in the PRODUCT.
- Railway companies or Public service purposes, and/or any other cases in which establishment of a special quality assurance system is required by the Purchaser or End User.
- Aircraft or Aerospace, Medical applications, Train equipment, transport equipment such as Elevator and Escalator, Incineration and Fuel devices, Vehicles, Manned transportation, Equipment for Recreation and Amusement, and Safety devices, handling of Nuclear or Hazardous Materials or Chemicals, Mining and Drilling, and/or other applications where there is a significant risk of injury to the public or property.

Notwithstanding the above, restrictions Mitsubishi may in its sole discretion, authorize use of the PRODUCT in one or more of the Prohibited Applications, provided that the usage of the PRODUCT is limited only for the specific applications agreed to by Mitsubishi and provided further that no special quality assurance or fail-safe, redundant or other safety features which exceed the general specifications of the PRODUCTS are required. For details, please contact the Mitsubishi representative in your region.

REVISIONS

* The manual number is noted at the lower right of the front cover

Print Date	*Manual Number	Revision
Apr., 2008	IB(NA)-0800423-A	First printing
Sep., 2008	IB(NA)-0800423-B	Correction SAFETY PRECAUTIONS
Oct., 2008	IB(NA)-0800423-C	Model addition Q00UJCPU Correction SAFETY PRECAUTIONS, About the Manuals, Section 1.1, Chapter 2
Jan., 2009	IB(NA)-0800423-D	Addition Chapter 4, Section 4.1, 4.1.1, 4.1.2, 4.1.3, 4.1.4, 4.1.5, 4.1.6, 4.2, 4.2.1, 4.2.2, 4.2.3, 4.2.4, 4.2.5, 4.2.6, Chapter 5
Apr., 2009	IB(NA)-0800423-E	Correction Chapter 5
Jan., 2010	IB(NA)-0800423-F	Correction SAFETY PRECAUTIONS, Section 4.1.3, Chapter 5 Addition CONDITIONS OF USE FOR THE PRODUCT
Feb., 2010	IB(NA)-0800423-G	Correction SAFETY PRECAUTIONS, Chapter 3, Section 4.1.3, 4.1.6
Mar., 2010	IB(NA)-0800423-H	Addition Warranty
May, 2010	IB(NA)-0800423-I	Model addition QY82P Correction Chapter 5
Jul., 2010	IB(NA)-0800423-J	Correction Section 4.1.1, 4.1.3
Sep., 2010	IB(NA)-0800423-K	Correction Section 4.1.1, 4.1.3
Aug., 2011	IB(NA)-0800423-L	Correction SAFETY PRECAUTIONS, Chapter 2, Section 4.1.1, 4.1.3, 4.1.6 Addition SAFETY PRECAUTIONS(Chinese)
Oct., 2011	IB(NA)-0800423-M	Correction Section 4.1.6
Dec., 2011	IB(NA)-0800423-N	Model addition QY41H Correction Chapter 2, 5
Nov., 2012	IB(NA)-0800423-O	Correction SAFETY PRECAUTIONS, Section 4.1.3, 4.1.6, 4.1.7, 4.2.2
May, 2013	IB(NA)-0800423-P	Correction SAFETY PRECAUTIONS, Section 4.1.3, 4.1.7
Nov., 2013	IB(NA)-0800423-Q	Correction SAFETY PRECAUTIONS, Chapter 5
May, 2014	IB(NA)-0800423-R	Correction SAFETY PRECAUTIONS, Chapter 5
Jul., 2014	IB(NA)-0800423-S	Correction SAFETY PRECAUTIONS

Print Date	*Manual Number	Revision
Sep., 2014	IB(NA)-0800423-T	<div style="border: 1px solid black; padding: 2px;">Model addition</div> Q64RPN <div style="border: 1px solid black; padding: 2px;">Correction</div> Section 5.2
Apr., 2015	IB(NA)-0800423-U	<div style="border: 1px solid black; padding: 2px;">Correction</div> Section 4.1.7
Aug., 2016	IB(NA)-0800423-V	<div style="border: 1px solid black; padding: 2px;">Correction</div> SAFETY PRECAUTIONS, Chapter 4, Section 4.1.3, 5.1 <div style="border: 1px solid black; padding: 2px;">Addition</div> Section 5.5

This manual confers no industrial property rights or any rights of any other kind, nor does it confer any patent licenses. Mitsubishi electric Corporation cannot be held responsible for any problems involving industrial property rights which may occur as a result of using the contents noted in this manual.

CONTENTS

1. Overview	1
1.1 Packing Lists	1
2. General Specifications	2
3. General Safety Requirements	3
4. EMC and Low Voltage Directives	8
4.1 Requirements for Compliance with the EMC Directive	8
4.1.1 Standards relevant to the EMC Directive	8
4.1.2 Installation instructions	10
4.1.3 Cables	11
4.1.4 Installation environment of the CC-Link/LT module and the AS-i module	19
4.1.5 Power supply part of the power supply module, Q00JCPU, and Q00UJCPU	20
4.1.6 When using MELSEC-A series modules	20
4.1.7 Others	22
4.2 Requirements to Compliance with the Low Voltage Directive	24
4.2.1 Standard applied for MELSEC-Q series programmable controllers	25
4.2.2 MELSEC-Q series programmable controller selection	25
4.2.3 Power supply	26
4.2.4 Control panel	26
4.2.5 External wiring	27
5. Mounting Modules and Wiring	28
5.1 Mounting modules	28
5.2 Wiring to the power supply module	33
5.3 Connection diagram of the input/output module	41
5.4 Wiring a terminal block	53
5.5 Replacement Procedure of the Q6BAT Battery	54
5.5.1 Basic model QCPU	54
5.5.2 High Performance model QCPU, Process CPU, Redundant CPU and Universal model QCPU	55

ABOUT THE MANUALS

Before using this product, always read the following detailed manuals.

Detailed Manuals (Sold separately)

CPU modules, Power supply modules, and Base units

Manual name	Manual No. (Model code)
QCPU User's Manual (Hardware Design, Maintenance and Inspection)	SH-080483ENG (13JR73)
QnUCPU User's Manual (Function Explanation, Program Fundamentals)	SH-080807ENG (13JZ27)
Qn(H)/QnPH/QnPRHCPU User's Manual (Function Explanation, Program Fundamentals)	SH-080808ENG (13JZ28)
I/O Module Type Building Block User's Manual	SH-080042 (13JL99)

1. Overview

This manual describes safety precautions for using the Q series modules.

1.1 Packing Lists

The following are included in the package.

(1) CPU module

(a) Q00JCPU or Q00UJCPU

Product Name	Quantity
Module	1
Battery (Q6BAT)	1
Base unit mounting screw (M4×14 screw)	4
This manual	1

(b) Other than Q00JCPU and Q00UJCPU

Product Name	Quantity
Module	1
Battery (Q6BAT)	1

(2) Main base unit

Product Name	Quantity
Unit	1
Base unit mounting screw (M4×14 screw *1)	4/5 *2
This manual	1

*1: For the slim type main base unit, M4×12 screws are supplied.

*2: Screws as many as the number of mounting holes are supplied.

(3) Extension base unit

Product Name	Quantity
Unit	1
Base unit mounting screw (M4×14 screw)	4/5 *3

*3: Screws as many as the number of mounting holes are supplied.

(4) Power supply module or I/O module

Product Name	Quantity
Module	1

2. General Specifications

This section provides specifications common to the relevant modules.

Item	Specifications					
Operating ambient temperature <i>Température ambiante de fonctionnement</i>	0 to 55°C 0 à 55 °C					
Storage ambient temperature	-25 to 75°C *1					
Operating ambient humidity	5 to 95%RH *2, non-condensing					
Storage ambient humidity						
Vibration resistance	Compliant with JIS B 3502 and IEC 61131-2	Under intermittent vibration	Frequency	Constant acceleration	Half amplitude	Sweep count
			5 to 8.4Hz	---	3.5mm	10 times each in X, Y, Z directions
		8.4 to 150Hz	9.8m/s ²	---		
		Under continuous vibration	5 to 8.4Hz	---	1.75mm	---
8.4 to 150Hz	4.9m/s ²	---				
Shock resistance	Compliant with JIS B 3502 and IEC 61131-2 (147 m/s ² , 3 times each in 3 directions X, Y, Z)					
Operating atmosphere	No corrosive gases					
Operating altitude *3	0 to 2000m					
Installation location	Inside a control panel					
Overtoltage category *4	II or less					
Pollution degree *5	2 or less					
Equipment class	Class I					

- *1 The storage ambient temperature is -20 to 75°C if the system includes any AnS/A series modules.
- *2 The operating and storage ambient humidity ranges are 10 to 90%RH if the system includes any AnS/A series modules.
- *3 Do not use or store the programmable controller under pressure higher than the atmospheric pressure of altitude 0m. Doing so may cause malfunction. When using the programmable controller under pressure, please consult your local Mitsubishi Electric representative.
- *4 This indicates the section of the power supply to which the equipment is assumed to be connected between the public electrical power distribution network and the machinery within premises. Category II applies to equipment for which electrical power is supplied from fixed facilities. The surge voltage withstand level for up to the rated voltage of 300V is 2500V.
- *5 This index indicates the degree to which conductive material is generated in terms of the environment in which the equipment is used. Pollution level 2 is when only non-conductive pollution occurs. A temporary conductivity caused by condensing must be expected occasionally.

3. General Safety Requirements

When a programmable controller is powered ON or OFF, proper output of the control target may not function temporarily due to delay and startup time differences between the power supply for the programmable controller and the external power supply for the control target (especially in the case of direct current (DC)).

For example, if an external power supply for a DC output module is turned on to control the target, and then the programmable controller is powered on, the DC output module may output an incorrect signal instantaneously when the programmable controller is powered on.

Therefore, it is necessary to configure a circuit by which a programmable controller is powered on first.

Also, an abnormal operation may occur if an external power supply or the programmable controller fails.

To prevent any of these abnormal operations from leading to the entire system failure, configure external failsafe circuits (an emergency stop circuit, protection circuit, and protective interlock circuits) in the areas where incorrect operation can result in mechanical damage or accidents.

The following pages give circuit examples of some system designs.

(1) System design circuit example (when not using $\overline{\text{ERR}}$ contact of power supply module/for Q00JCPU)

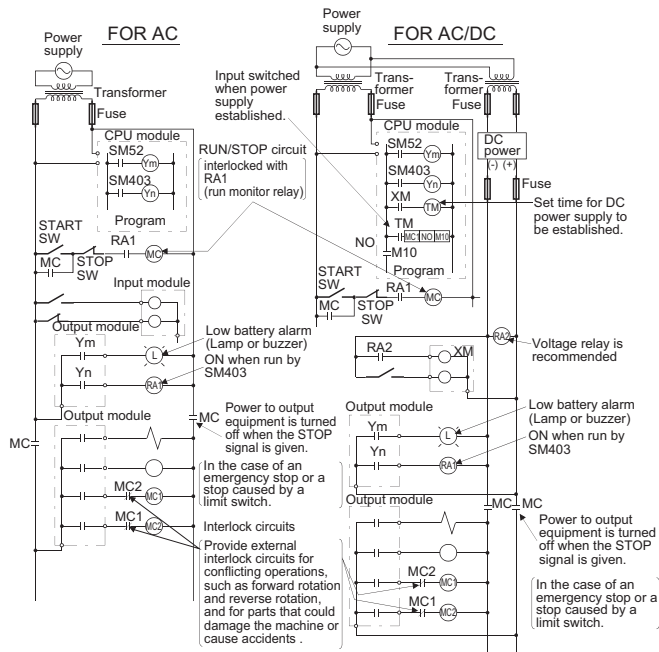

The power-ON procedure is as follows:

For AC

- 1) Switch the power to ON.
- 2) Set the CPU module to RUN.
- 3) Turn ON the start switch.
- 4) When the magnetic contactor (MC) comes on, the output equipment is powered and may be driven by the program.

For AC/DC

- 1) Switch the power to ON.
- 2) Set the CPU module to RUN.
- 3) When DC power is established, RA2 goes ON.
- 4) Timer (TM) times out after the DC power reaches 100%. (The TM set value should be the period of time from when RA2 goes ON to the establishment of 100% DC voltage. Set this value to approximately 0.5 seconds.)
- 5) Turn ON the start switch.
- 6) When the magnetic contactor (MC) comes on, the output equipment is powered and may be driven by the program. (If a voltage relay is used at RA2, no timer (TM) is required in the program.)

(2) System design circuit example (when using $\overline{\text{ERR}}$ contact of power supply module)

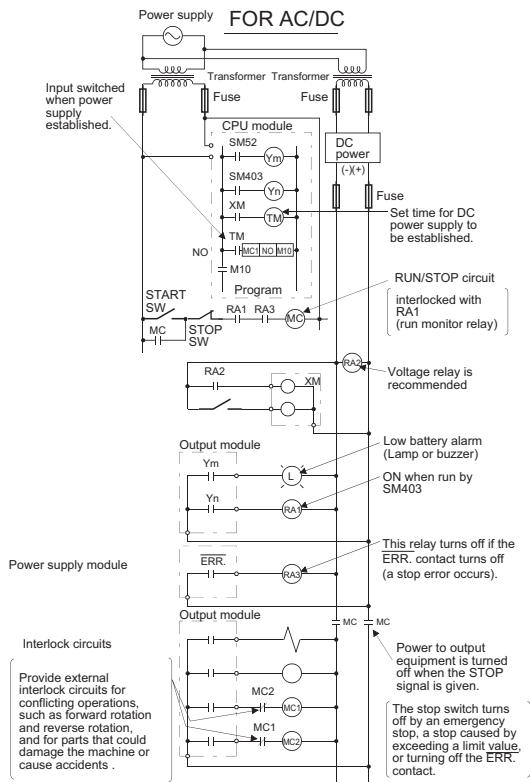

The power-ON procedure is as follows:

For AC/DC

- 1) Switch the power to ON.
- 2) Set the CPU module to RUN.
- 3) When DC power is established, RA2 goes ON.
- 4) Timer (TM) times out after the DC power reaches 100%. (The TM set value should be the period of time from when RA2 goes ON to the establishment of 100% DC voltage. Set this value to approximately 0.5 seconds.)
- 5) Turn ON the start switch.
- 6) When the magnetic contactor (MC) comes on, the output equipment is powered and may be driven by the program. (If a voltage relay is used at RA2, no timer (TM) is required in the program.)

- (3) Fail-safe measures against failure of programmable controllers
- The self-diagnostic function can detect a failure of a CPU module or memory. However, if an error occurs in an area, such as I/O control area, the CPU module may not be able to detect the error. In this case, all I/O points may turn ON or OFF depending on the condition of the problem, and normal operation and safety cannot be ensured.

Although Mitsubishi programmable controllers are manufactured under strict quality control, it is recommended to configure external failsafe circuits to prevent mechanical damage or accidents caused by failure of a programmable controller.

Examples of a system and its fail-safe circuitry are described below:

<System example>

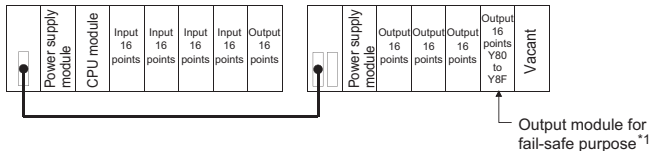

- *1 The output module for fail-safe purpose should be loaded in the last slot of the system. (Y80 to Y8F in the above system.)

<Fail-safe circuit example>

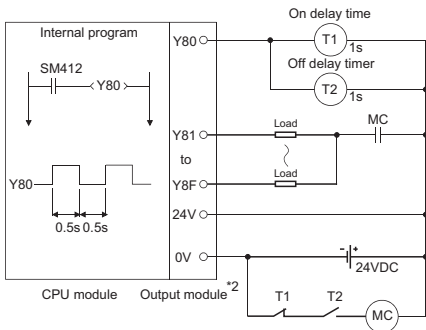

- *2 Y80 turns ON and then OFF at 0.5 second intervals.
Use a no-contact output module (transistor in the example shown above).

4. EMC and Low Voltage Directives

Compliance to the EMC Directive, which is one of the EU Directives, has been a legal obligation for the products sold in European countries since 1996 as well as the Low Voltage Directive since 1997. Manufacturers who recognize their products are compliant to the EMC and Low Voltage Directives are required to declare that print a "CE mark" on their products.

- (1) Authorized representative in Europe
Authorized representative in Europe is shown below.
Name: MITSUBISHI ELECTRIC EUROPE B.V.
Address: Mitsubishi-Electric-Platz 1, 40882 Ratingen, Germany

4.1 Requirements for Compliance with the EMC Directive

The EMC Directive specifies that products placed on the market must be so constructed that they do not cause excessive electromagnetic interference (emissions) and are not unduly affected by electromagnetic interference (immunity). Section 4.1.1 to Section 4.1.7 summarize the precautions on compliance with the EMC Directive of the machinery constructed with the MELSEC-Q series programmable controllers. These precautions are based on the requirements and the standards of the regulation, however, it does not guarantee that the entire machinery constructed according to the descriptions will comply with above-mentioned directive. The method and judgement for complying with the EMC Directive must be determined by the person who construct the entire machinery.

4.1.1 Standards relevant to the EMC Directive

- (1) Regulations regarding emission

Standard	Test item	Test description	Value specified in standard
EN61131-2:2007	CISPR16-2-3 Radiated emission *2	Radio waves from the product are measured.	30M-230MHz • QP: 40dB μ V/m (10m in measurement range) *1 • 230M-1000MHzQP: 47dB μ V/m (10m in measurement range)
	CISPR16-2-1, CISPR16-1-2 Conducted emission *2	Noise from the product to the power line is measured.	• 150k-500kHz QP: 79dB, Mean: 66dB *1 • 500k-30MHz QP: 73dB, Mean: 60dB

*1 QP: Quasi-peak value, Mean: Average value

*2 Programmable controllers are open-type devices (devices designed to be housed inside other equipment) and must be installed inside a conductive control panel. The corresponding tests were conducted with the programmable controller installed inside a control panel.

(2) Regulations regarding immunity

Standard	Test item	Test description	Value specified in standard
EN61131-2:2007	EN61000-4-2 Electrostatic discharge immunity ^{*1}	Immunity test in which electrostatic is applied to the cabinet of the equipment.	<ul style="list-style-type: none"> • 8kV Air discharge • 4kV Contact discharge
	EN61000-4-3 Radiated, radio-frequency, electromagnetic field immunity ^{*1}	Immunity test in which electric fields are irradiated to the product.	<ul style="list-style-type: none"> • 80% AM modulation@1kHz • 80M-1000MHz: 10V/m • 1.4G-2.0GHz: 3V/m • 2.0G-2.7GHz: 1V/m
	EN61000-4-4 Electrical fast transient/burst immunity ^{*1}	Immunity test in which burst noise is applied to the power line and signal line.	<ul style="list-style-type: none"> • AC/DC main power, I/O power, AC I/O (unshielded): 2kV • DC I/O, analog, communication: 1kV
	EN61000-4-5 Surge immunity ^{*1}	Immunity test in which lightning surge is applied to the power line and signal line.	<ul style="list-style-type: none"> • AC power line, AC I/O power, AC I/O (unshielded) : 2kV CM, 1kV DM • DC power line, DC I/O power : 0.5kV CM, DM • DC I/O, AC I/O (shielded), analog^{*2}, communication: 1kV CM
	EN61000-4-6 Immunity to conducted disturbances, induced by radio-frequency fields ^{*1}	Immunity test in which high frequency noise is applied to the power line and signal line	0.15M-80MHz, 80% AM modulation@1kHz, 10Vrms
	EN61000-4-8 Power-frequency magnetic field immunity ^{*1}	Immunity test in which the product is installed in inductive magnetic field	50Hz/60Hz, 30A/m
	EN61000-4-11 Voltage dips and interruption immunity ^{*1}	Immunity test in which power supply voltage is momentarily interrupted	<ul style="list-style-type: none"> • Apply at 0%, 0.5 cycles and zero-cross point • 0%, 250/300 cycles (50/60Hz) • 40%, 10/12 cycles (50/60Hz) • 70%, 25/30 cycles (50/60Hz)

*1 Programmable controllers are open-type devices (devices designed to be housed inside other equipment) and must be installed inside a conductive control panel. The corresponding tests were conducted with the programmable controller installed inside a control panel.

*2 The accuracy of an analog-digital converter module may temporary vary within $\pm 10\%$.

4.1.2 Installation instructions

Programmable controller is an open type device and must be installed inside a control panel for use. *1

This not only ensures safety but also ensures effective shielding of programmable controller-generated electromagnetic noise.

*1 Also, each network remote station needs to be installed inside the control panel. However, the waterproof type remote station can be installed outside the control panel.

- (1) Control panel
 - (a) Use a conductive control panel.
 - (b) When attaching the control panel's top plate or base plate, mask painting and weld so that good surface contact can be made between the panel and plate.
 - (c) To ensure electrical contact between the inner plate and control panel, mask the bolt areas when painting to ensure conductivity in the largest possible area.
 - (d) Ground the control panel with a thick ground cable so that low impedance can be ensured even at high frequencies.
 - (e) Holes made in the control panel must be 10 cm diameter or less. If the holes are 10 cm or larger, radio frequency noise may be emitted. In addition, because radio waves leak through a clearance between the control panel door and the main unit, reduce the clearance as much as practicable. The leakage of radio waves can be suppressed by the direct application of an EMI gasket on the paint surface.

The tests were conducted by Mitsubishi Electric Corporation using a control panel having damping characteristics of 37dB (maximum) and 30dB (average) (measured at 3m distance, 30 to 300MHz).

- (2) Connection of power and ground cables

Ground wire and power supply cable for the programmable controller system must be connected as described below.

 - (a) Provide a ground point near the power supply module. Ground the LG (Line Ground) and FG (Frame Ground) terminals of the power supply module with the thickest and shortest ground cable possible (30 cm or shorter). Because the LG and FG terminals pass the noise generated in the programmable controller to the ground, ensure the lowest possible impedance.

Also, since the ground cable itself carries a large noise, short wiring prevents the cable from acting as an antenna.

- (b) The ground wire led from the grounding point must be twisted with the power supply wires. By twisting with the ground wire, noise flowing from the power supply wires can be relieved to the ground. However, if a filter is installed on the power supply wires, the wires and the ground wire may not need to be twisted.

4.1.3 Cables

The cables extracted from the control panel contain a high frequency noise component. On the outside of the control panel, therefore, they serve as antennas to emit noise. To prevent noise emission, use shielded cables for the cables which are connected to the I/O modules and intelligent function modules and may be extracted to the outside of the control panel.

The use of a shielded cable also increases noise resistance.

The signal lines (including common line) of the programmable controller, which are connected to I/O modules, intelligent function modules and/or extension cables, have noise durability in the condition of grounding their shields by using the shielded cables. If a shielded cable is not used or not grounded correctly, the noise resistance will not meet the specified requirements.

- (1) Grounding the shield of the shield cable
 - (a) Ground the shield of the shielded cable as near the module as possible so that the grounded cable will not be affected by electromagnetic induction from ungrounded cables.
 - (b) Ground the exposed shield section to spacious area on the control panel. A clamp can be used as shown in below. In this case, mask off inner wall surface of the control panel, which comes in contact with the clamp.

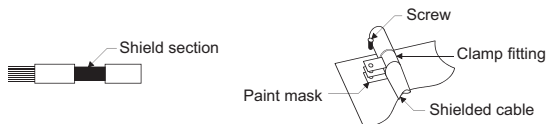

Note) The method of grounding with a vinyl-coated wire soldered onto the shielded section of the shielded cable as in shown below is not recommended. Doing so will raise the high-frequency impedance, resulting in loss of the shielding effect.

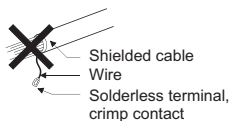

(2) Grounding cables using a cable clamp

Use shielded cables for external wiring of the following modules, and ground the shield section of the shielded cable to the control panel using the AD75CK cable clamp (Mitsubishi). (Ground the shield section within 20 to 30cm from the module.)

- CC-Link IE Field Network module
- Positioning module
- Channel isolated pulse input module
- Multichannel high-speed counter module
- Loop control module
- Load cell input module
- Temperature control module
- 4Mpps capable high-speed counter module
- Multi function counter/timer module
- Analog I/O module

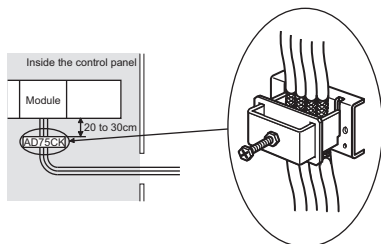

The AD75CK enables up to four cables to be grounded together if the outside diameter of the shielded cable is about 7mm. For details of the AD75CK, refer to the AD75CK-type Cable Clamping Instruction Manual.

(3) MELSECNET/H network modules

Always use a double-shielded coaxial cable (MITSUBISHI CABLE INDUSTRIES, LTD.: 5C-2V-CCY) for the coaxial cables MELSECNET/H network module.

Radiated noise in the range of 30MHz or higher can be suppressed by using double-shielded coaxial cables. Ground the double-shielded coaxial cable by connecting its outer shield to the ground.

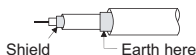

Refer to (1) in this section for grounding the shield.

- (4) Built-in Ethernet port QCPU, Ethernet interface modules, FL-net (OPCN-2) interface modules, Web server modules, MES interface modules, high speed data logger modules, high speed data communication module, and MODBUS/TCP interface modules
Precautions for AUI cables, twisted pair cables, and coaxial cables are described below.

- (a) Always ground the AUI cables ^{*1} connected to the 10BASE5 connectors. Because the AUI cable is a shielded type, strip part of the jacket as shown below and ground the exposed shield section to the ground as much as possible.

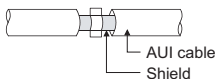

Refer to (1) in this section for grounding the shield.

- ^{*1} Make sure to install a ferrite core for the cable.
As a ferrite core, ZCAT2032 manufactured by TDK is recommended.

- (b) Always use shielded twisted pair cables for connection to 10BASE-T and 100BASE-TX connectors.
For the shielded twisted pair cable, remove a part of the jacket as shown below and ground the exposed shield section to the ground as much as possible.

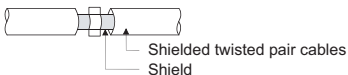

Refer to (1) in this section for grounding the shield.

- (c) Always use double-shielded coaxial cables as the coaxial cables *2 connected to the 10BASE2 connectors.
Ground the double-shielded coaxial cable by connecting its outer shield to the ground.

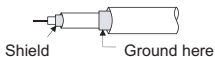

Refer to (1) in this section for grounding the shield.

- *2 Make sure to install a ferrite core for the cable.
As a ferrite core, ZCAT3035 manufactured by TDK is recommended.

(5) CC-Link IE Field Network module

The following describes precautions for using CC-Link IE Field Network cables.

- (a) Use the CC-Link IE Field Network cable (SCE5EW-S□M).
(b) Because the CC-Link IE Field Network cable is a shielded type, strip part of the jacket as shown below and ground the exposed shield section to the ground as much as possible.



(6) CC-Link system master/local module

- (a) Be sure to ground the cable shield that is connected to the CC-Link module close to the exit of control panel or to any of the CC-Link stations within 30cm from the CC-Link system master/local module or stations.

The CC-Link dedicated cable is a shielded cable. Remove a part of the jacket as shown below and ground the exposed shield section to the ground as much as possible.

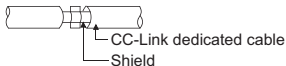

- (b) Always use the specified CC-Link dedicated cable.
(c) The CC-Link module, the CC-Link stations and the FG line inside the control panel must be connected at the FG terminal as shown below.

[Simplified diagram]

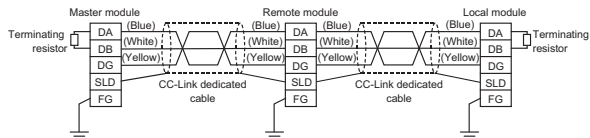

- (d) Use a CE-marked power supply to which the module power supply or external power supply is connected. Ground the FG terminals.

Power supply model name	DLP75-24-1	DLP100-24-1	DLP-120-24-1	DLP180-24-1	DLP240-24-1	
Rated input voltage	100 to 240VAC					
Rated output	Voltage	24VDC				
	Current	3.1A	4.1A	5.0A	7.5A	10.0A

- (e) Each power line connecting to the external power supply terminal or module power supply terminal must be 30m (98.43 ft) or less.
- (f) Install a noise filter to the external power supply. Use the noise filter having an attenuation characteristic, MA1206 (TDK-Lambda) or equivalent. Note that a noise filter is not required if the module is used in Zone A defined in EN61131-2.
- (g) Keep the length of signal cables connected to the analog input terminals of the following modules to 30m or less. Wire cables connected to the external power supply and module power supply terminal in the control panel where the module is installed.
- AJ65BT-64RD3
 - AJ65BT-64RD4
 - AJ65BT-68TD
- (h) For the cable connected to the power supply terminal of the AJ65SBT-RPS, AJ65SBT-RPG or AJ65BT-68TD, install a ferrite core with attenuation characteristic equivalent to that of the ZCAT3035-1330 from TDK Corporation. Twist the cable around the ferrite core by one as shown below.

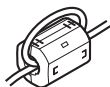

- (i) To supply the module power supply terminal of the AJ65BTB2-16R/16DR, AJ65SBTB2N-8A/8R/8S/16A/16R/16S with power using the AC/DC power supply, follow as shown below.
- Install the AC/DC power supply in the control panel where the module is installed.
 - Use a CE-marked AC/DC power supply and ground the FG terminals.
(The AC/DC power supply used for the tests conducted by Mitsubishi: TDK-Lambda Corporation: DLP-120-24-1)
 - For the cable connected to the AC input terminal and DC output terminals of the AC/DC power supply, attach a ferrite core. Twist the cable around the ferrite core by one as shown below.
(Ferrite core used for the tests conducted by Mitsubishi: NEC TOKIN Corporation: ESD-SR-250)

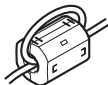

- (7) CC-Link/LT module
To supply the CL2DA2-B and CL2AD4-B with power using the CL1PAD1, keep the length of the power cable connected from the CL1PAD1 to the external power supply to 30m or less.
- (8) Positioning module
- The cable connecting the drive unit and the QD75 must be the length below.
 - QD75P□N/QD75P□ : 2m or shorter
 - QD75D□N/QD75D□ : 10m or shorter
 - The cables connected to the external device for the QD75 must be 30m or shorter. (except the one for pulse output)
- (9) 4Mpps capable high-speed counter module
- Keep the length of a power cable connected to the external coincidence output power supply terminal to 10m or less.
 - Keep the length of a cable connected to an external device to 30m or less.
- (10) Multi function counter/timer module
- Install the DC power connected to the encoder inside the same control panel where the module is installed.

- Install a ferrite core to each DC power cable connected to the module and the controller. The ferrite core ZCAT3035-1330 (TDK Corporation) is recommended.
- Keep the length of a cable connected to the encoder to 3m or less.
- Keep the length of a cable connected to the controller or external output terminal to 30m or less.
- Keep the length of a DC power cable connected to the external device to 3m or less.

(11) Q68TD-G (-H01/-H02) type channel isolated thermocouple input module and Q68RD3-G type channel isolated RTD input module
Wiring as shown below is required.

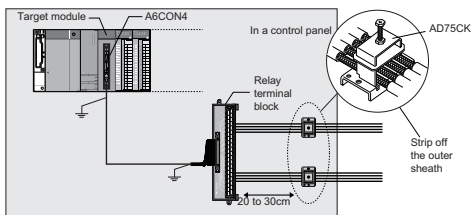

- Use a shielded cable for connection between the external device connector and relay terminal block, and ground the shield section of the cable to the control panel. Keep the wiring length to 3m or less.
- Use a shielded cable for external wiring, and ground the shield section of the cable to the control panel using the AD75CK cable clamp (Mitsubishi). (Ground the shield section within 20 to 30cm from the relay terminal block.)
- Before handling the relay terminal block, touch a grounded metal object to discharge the static electricity from the human body.

(12) Analog I/O module

Install a ferrite core to the external power supply connection cable, keeping a distance of 4cm from the module.

Ferrite core: ZCAT3035-1330 manufactured by TDK Corporation

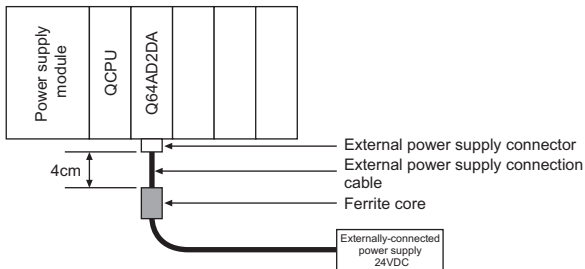

(13) Redundant CPU

Be sure to use the QC□TR for the tracking cable, and ground the shielded part of the cable to the panel with the AD75CK cable clamp (Mitsubishi).

For the grounding method, refer to (2) in this section.

(14) I/O signal lines and other communication cables

- For the I/O signal lines (including common line) and other communication cables (RS-232, RS-422, CC-Link, etc.), always ground the shields of the shield cables as (1) in this section if they are pulled out of the control panel.
- To set the input response time of the input module and the interrupt module to 0.1ms or less, keep the each cable length of I/O signal cables (including common lines) to 30m or shorter.

(15) Extension cables

For an extension cable, always ground the shields of the shield cables as (1) in this section if they are pulled out of the control panel.

(16) Power line for external power supply terminal

(a) Use a CE-marked AC-DC power supply as an external power supply for the following modules. Install the AC-DC power supply in the control panel where the module is installed. Keep the length of the power cable connected to the external power supply terminal to 30m or less.

- Analog-digital converter module
- Digital-analog converter module
- Analog input/output module
- Load cell input module
- Temperature input module
- Temperature control module
- Loop control module
- Pulse input module
- High-speed counter module
- Positioning module

(b) Use a CE-marked AC-DC power supply as an external power supply for the QJ71LP21S-25.

(c) Use a CE-marked AC-DC power supply as an external power supply for the QJ71E71-B5 and QJ71FL71-B5 (-F01). A power line connecting to the external power supply terminal must be 3m (9.84 ft) or less.

(17) Adjacent cables

Install ferrite cores on the both ends of RS-232 and USB cables that are extended out of the control panel.

4.1.4 Installation environment of the CC-Link/LT module and the AS-i module

(1) CC-Link/LT module

Use the module under the environment of Zone A *1.

For the categories of the following products, refer to the manual came with each product.

- CL1Y4-R1B1
- CL1Y4-R1B2
- CL1XY4-DR1B2
- CL1XY8-DR1B2
- CL1PSU-2A

(2) AS-i module

Use the module under the environment of Zone A *1.

*1 Zone defines categories according to industrial environment, specified in the EMC and Low Voltage Directives, EN61131-2.

Zone C: Factory mains (isolated from public mains by dedicated transformer)

Zone B: Dedicated power distribution, secondary surge protection (rated voltage: 300V or less)

Zone A: Local power distribution, protected from dedicated power distribution by AC/DC converter and insulation transformer (rated voltage: 120V or less)

4.1.5 Power supply part of the power supply module, Q00JCPU, and Q00UJCPU

Ground the LG and FG terminals by using a ground wire as thick and short as possible (2mm in diameter).

4.1.6 When using MELSEC-A series modules

The following describes the case where the MELSEC-A series module is used, using the QA1S5□B, QA1S6□B, QA1S6ADP+A1S5□B/A1S6□B, QA6□B, and QA6ADP+A5□B/A6□B as the extension base unit.

(1) Cable

(a) Grounding the shield section of shielded cable

For grounding the shield section of the shielded cable, refer to Section 4.1.3 (1).

(b) Positioning modules

Precautions for configuring the machinery compliant with the EMC Directives using the A1SD75P□-S3 (abbreviated as A1SD75 hereafter), AD75P□-S3 (abbreviated as AD75 hereafter) are described below.

1) When wiring cable of a 2 m (6.56 ft) or less

- Ground the shield of the external device connection cable with a cable clamp. (Ground the shield at the closest location to the A1SD75/AD75 external wiring connector.)
- Wire external device connection cables to drive modules and external devices by the shortest distance.

- Install the drive unit in the same panel.

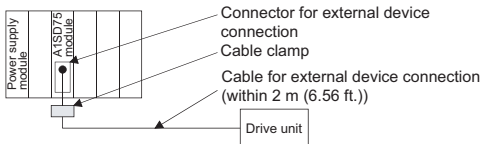

- 2) When wiring with cable that exceeds 2 m (6.56 ft), but is 10 m (32.81 ft) or less

- Ground the shield of the external device connection cable with a cable clamp. (Ground the shield at the closest location to the A1SD75/AD75 external wiring connector.)
- Wire external device connection cables to drive modules and external devices by the shortest distance.
- Install a ferrite core.

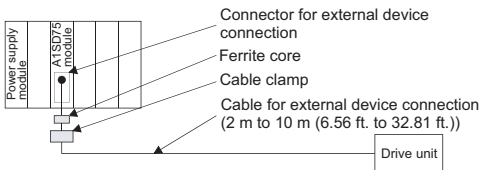

- 3) Ferrite core and cable clamp types

- Cable clamp
Type: AD75CK (Mitsubishi)
- Ferrite core
Type: ZCAT3035-1330 (TDK ferrite core)

Cable length	Prepared part	Required Qty		
		1 axis	2 axis	3 axis
2 m (6.56 ft) or less	AD75CK	1	1	1
Over 2 m (6.56 ft) to 10m (32.81 ft)	AD75CK	1	1	1
	ZCAT3035-1330	1	2	3

- 4) Cable clamp mounting position

For the grounding method, refer to Section 4.1.3 (2).

- (c) I/O signal lines

For the I/O signal lines (including common line), if extracted to the outside of the control panel, also ensure to ground the shield section of these lines and cables in the same manner as in item Section 4.1.3 (1) above.

- (d) Extension cable

For an extension cable, always ground the shield section of the shield cables as in Section 4.1.3 (1) if they are pulled out of the control panel.

(2) Power supply module

The precautions required for each power supply module are described in below. Always observe the items noted as precautions.

Model	Precautions
A1S61P, A1S62P, A61P, A62P	N/A
A1S63P *1, A63P	Use a CE-compliant product for the power supply equipment inside the 24VDC control panel.
A1S61PEU, A1S62PEU, A1S61PN, A1S62PN, A61PN, A68P, A61PEU, A62PEU	Ground the LG and FG terminals after short-circuiting them.

*1 Installing a filter to a power line is not required if the version of the A1S63P is F or later.

Make sure to use the CE-marked 24VDC panel power equipment.

4.1.7 Others

(1) SD memory card

The SD memory cards manufactured by Mitsubishi (NZ1MEM-□GBSD and L1MEM-□GBSD) conform to IEC 61131-2 when being used in a CPU module.

(2) Ferrite core

A ferrite core has the effect of reducing radiated noise in the 30MHz to 100MHz band. It is not required to fit ferrite cores to cables, but it is recommended to fit ferrite cores if shield cables pulled out of the enclosure do not provide sufficient shielding effects.

Note that the ferrite cores must be fitted to the cables in the position immediately before they are pulled out of the enclosure. If the fitting position is improper, the ferrite will not produce any effect.

(3) Noise filter (power supply line filter)

A noise filter is a component which has an effect on conducted noise.

It is not required to attach the noise filter to the power supply line except the A61PEU, A62PEU power supply modules and some models, however, attaching it can suppress more noise. (The noise filter has the effect of reducing conducted noise of 10 MHz or less.) The precautions required when installing a noise filter are described below

- (a) Do not bundle the wires on the input side and output side of the noise filter. When bundled, the output side noise will be induced into the input side wires from which the noise was filtered.

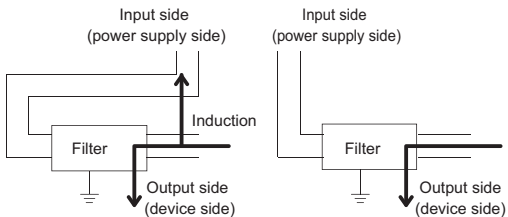

- 1) The noise will induct into input side when the input and output wires are bundled. 2) Separate the input and output wires.

- (b) Ground the noise filter grounding terminal to the control cabinet with the shortest wire possible (approx. 10 cm).

Reference

Noise filter model	FN343-3/01	FN660-6/06	ZHC2203-11
Manufacturer	SCHAFFNER	SCHAFFNER	TDK
Rated current	3 A	6 A	3 A
Rated voltage	250V		

(4) Isolation transformer

An isolation transformer has an effect on reducing conducted noise (especially, lightning surge).

Lightning surge may cause a malfunction of the programmable controller.

As a measure against lightning surge, connect an isolation transformer as shown below.

The use of an isolation transformer reduces an impact of lightning.

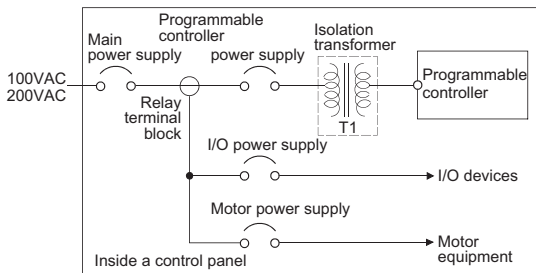

4.2 Requirements to Compliance with the Low Voltage Directive

The Low Voltage Directive requires each device that operates with the power supply ranging from 50 to 1000VAC and 75 to 1500VDC to satisfy the safety requirements. In Section 4.2.1 to Section 4.2.5, cautions on installation and wiring of the MELSEC-Q series programmable controller to comply with the Low Voltage Directive are described. These descriptions are based on the requirements and standards of the regulation, however, it does not guarantee that the entire machinery manufactured based on the descriptions complies with the above-mentioned directive. The method and judgment for the low voltage directive must be left to the manufacturer's own discretion.

4.2.1 Standard applied for MELSEC-Q series programmable controllers

The standard applied to MELSEC-Q series programmable controllers: EN61131-2 Safety of equipment used in measurements, controls, or laboratories.

The MELSEC-Q series programmable controllers with a rated voltage of 50VAC/75VDC or higher have been also developed to conform to the above standard.

The modules which operate at the rated voltage of less than 50VAC/75VDC are out of the Low Voltage Directive application range.

4.2.2 MELSEC-Q series programmable controller selection

(1) Power supply module

There are dangerous voltages (voltages higher than 42.4V peak) inside the power supply modules of 100/200VAC rated I/O voltages. Therefore, the CE marked models are enhanced in insulation internally between the primary and secondary.

(2) I/O module

There are dangerous voltages in the I/O modules of 100/200VAC rated I/O voltages.

Therefore, the CE marked models are enhanced in insulation internally between the primary and secondary.

The I/O modules of 24VDC or less rating are out of the Low Voltage Directive application range.

(3) CPU module, memory card, SD memory card, extended SRAM cassette, and base unit

Using 5VDC circuits inside, the above modules are out of the Low Voltage Directive application range.

(4) Intelligent function modules (special function modules)

The intelligent function modules such as analog-digital converter modules, digital-analog converter modules, network modules, and positioning modules (special function modules) are out of the scope of the low voltage directive because the rated voltage is 24VDC or less.

(5) Display device

Use the CE marked display device.

4.2.3 Power supply

The insulation specification of the power supply module was designed assuming installation category II. Be sure to use the installation category II power supply to the programmable controller. The installation category indicates the durability level against surge voltage generated by a thunderbolt. Category I has the lowest durability; category IV has the highest durability.

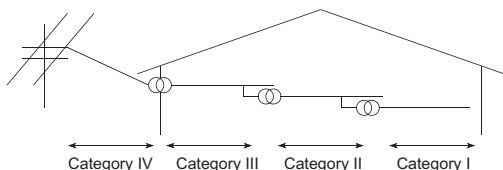

Category II indicates a power supply whose voltage has been reduced by two or more levels of isolating transformers from the public power distribution.

4.2.4 Control panel

Programmable controller is an open type device (a device designed to be housed inside other equipment) and must be installed inside a control panel for use. *1

*1 Also, each network remote station needs to be installed inside the control panel. However, the waterproof type remote station can be installed outside the control panel.

(1) Electrical shock prevention

The control panel must be handled as shown below to protect a person who does not have adequate knowledge of electricity from an electric shock.

- Lock the control panel so that only those who are trained and have acquired enough knowledge of electric facilities can open the control panel.
- The control panel must have a structure which automatically stops the power supply when the box is opened.
- For electric shock protection, use IP20 or greater control panel.

(2) Dustproof and waterproof features

The control panel also has the dustproof and waterproof functions. Insufficient dustproof and waterproof features lower the insulation withstand voltage, resulting in insulation destruction.

The insulation in our programmable controller is designed to cope with the pollution level 2, so use in an environment with pollution level 2 or below.

Pollution degree 1: An environment where the air is dry and conductive dust does not exist.

Pollution degree 2: An environment where conductive dust does not usually exist, but occasional temporary conductivity occurs due to the accumulated dust. Generally, this is the level for inside the control box equivalent to IP54 in a control room or on the floor of a typical factory.

Pollution degree 3: An environment where conductive dust exists and conductivity may be generated due to the accumulated dust. An environment for a typical factory floor.

Pollution degree 4: Continuous conductivity may occur due to rain, snow, etc. An outdoor environment.

As shown above, the programmable controller can realize the pollution level 2 when stored in a control panel equivalent to IP54.

4.2.5 External wiring

(1) Module power supply and external power supply

For the remote module which requires 24VDC as module power supply, the 5/12/24/48VDC I/O module, and the intelligent function module (special function module) which requires the external power supply, use the 5/12/24/48VDC circuit which is doubly insulated from the hazardous voltage circuit or use the power supply whose insulation is reinforced.

(2) External devices

When a device with a hazardous voltage circuit is externally connected to the programmable controller, use a model whose circuit section of the interface to the programmable controller is intensively insulated from the hazardous voltage circuit.

(3) Intensive insulation

The intensive insulation covers the withstand voltages shown below.

(Installation Category II, source: IEC 664)

Rated voltage of hazardous voltage area	Surge withstand voltage (1.2/50 μ s)
150VAC or lower	2500V
300VAC or lower	4000V

5. Mounting Modules and Wiring

5.1 Mounting modules

Montage des modules

When installing the programmable controller in a control panel, fully consider its operability, maintainability, and environmental resistance. Securely mount all the MELSEC-Q series modules used on the base unit. For details on the mounting method, refer to the QCPU User's Manual (Hardware Design, Maintenance and Inspection).

Pour installer l'automate programmable dans un tableau de commande, prendre en compte tous les aspects d'operabilite, de maintenabilite et de resistance a l'environnement. Monter fermement sur l' unite de base tous les modules de la serie MELSEC-Q a utiliser. Pour le detail de la methode de montage, voir le Manuel de l'utilisateur QCPU (conception du materiel, maintenance et inspection).

(1) Module mounting position

To ensure good ventilation and ease module change, provide clearance between the module top/bottom and structures/parts as shown below.

(a) In case of main base unit or extension base unit

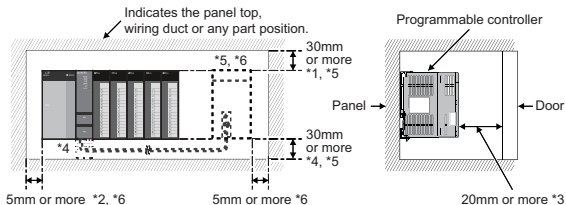

*1 For wiring duct with 50mm or less height. 40mm or more for other cases.

*2 20mm or more when the adjacent module is not removed and the extension cable is connected.

*3 80mm or more for the connector type. 140mm or more for installing a tracking cable when using a Redundant CPU. 80mm or more for installing the Q8BAT cable when using the Q8BAT.

*4 45mm or more when the Q7BAT is mounted.

*5 30mm or more from the top and bottom of the Q8BAT when the Q8BAT is mounted.

*6 5mm or more from the right and left of the Q8BAT when the Q8BAT is mounted.

(b) In case of slim type main base unit

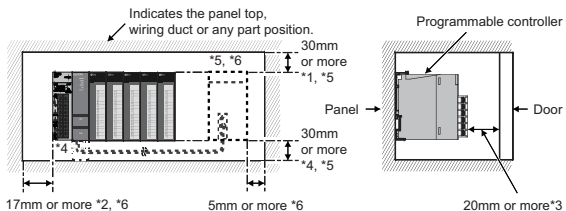

- *1 For wiring duct with 50mm or less height. 40mm or more for other cases.
- *2 The cable of the power supply module of the slim type main base unit protrudes out of the left end of the module. Install the module while reserving 17mm or more wiring space. If the cable sheath is susceptible to damage caused by a structural object or part on the left side of the module, take a protective measure with spiral tube or a similar insulator.
- *3 80mm or more for the connector type. 80mm or more for installing the Q8BAT cable when using the Q8BAT.
- *4 45mm or more when the Q7BAT is mounted.
- *5 30mm or more from the top and bottom of the Q8BAT when the Q8BAT is mounted.
- *6 5mm or more from the right and left of the Q8BAT when the Q8BAT is mounted.

(1) *Position de montage du module*

Pour assurer une bonne ventilation et faciliter le remplacement des modules, prévoir les débattements indiqués ci-dessous entre haut/bas de module et structure environnante/autre organe.

(a) *Cas de l'unité de base principale ou d'une unité de base d'extension*

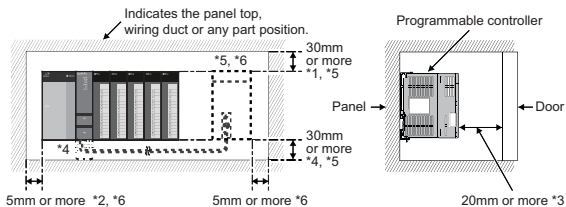

English	French
20mm or more	20mm au minimum
30mm or more	30mm au minimum
5mm or more	5mm au minimum
Door	Porte
Panel	Panneau
Programmable controller	Automate programmable

- *1 Pour conduit de câblage de moins de 50mm de haut. 40mm au minimum dans les autres cas.
- *2 20mm au minimum si le module voisin n'est pas amovible et est connecté par une rallonge de câble.
- *3 80mm au minimum pour un module de type connecteur. 140mm au minimum pour installer le câble de poursuite si on utilise une CPU redondante. 80mm au minimum pour installer le câble du Q8BAT si on utilise un Q8BAT.
- *4 45mm au minimum pour installer le Q8BAT.
- *5 30mm au minimum du haut ou du bas du Q8BAT si on installe un Q8BAT.
- *6 5mm au minimum de la droite ou de la gauche du Q8BAT si on installe un Q8BAT.

(b) Dans le cas d'une unité de base de type compact

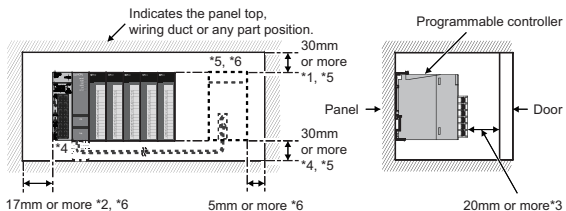

English	French
17mm or more	17mm au minimum
20mm or more	20mm au minimum
30mm or more	30mm au minimum
5mm or more	5mm au minimum
Door	Porte
Panel	Panneau
Programmable controller	Automate programmable

*1 Pour conduit de câblage de moins de 50mm de haut. 40mm au minimum dans les autres cas.

*2 Le câble du module d'alimentation d'une unité de base de type compact dépasse sur la gauche du module. Installer le module avec un débattement d'au minimum 17mm pour le câblage. Si la gaine de câble risque d'être endommagée au contact de la structure environnante ou d'un autre objet, prévoir une protection isolante comme un tube souple.

*3 80mm au minimum pour un module de type connecteur. 80mm au minimum pour installer le câble du Q8BAT si on utilise un Q8BAT.

*4 45mm au minimum pour installer le Q8BAT.

*5 30mm au minimum du haut ou du bas du Q8BAT si on installe un Q8BAT.

*6 5mm au minimum de la droite ou de la gauche du Q8BAT si on installe un Q8BAT.

(2) Module mounting orientation

- To ensure good ventilation for heat dissipation, install the programmable controller in the orientation as shown below.

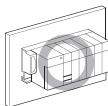

- Do not mount the programmable controller in the orientations as shown below.

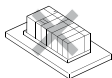
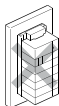

Vertical mounting Horizontal installation

(2) *Sens de montage du module*

- *Pour une bonne ventilation et une bonne dissipation de la chaleur, installer l'automate programmable dans le sens de l'illustration ci-après.*

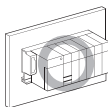

- *Ne pas installer l'automate programmable dans le sens de l'illustration ci-dessous.*

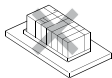
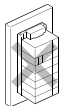

Vertical mounting Horizontal installation

English	French
Horizontal installation	<i>Montage horizontal</i>
Vertical mounting	<i>Montage vertical</i>

5.2 Wiring to the power supply module

Câblage de module d'alimentation

The following figures show wiring examples of cables such as power cables and ground wires to the main base unit and extension base units.

Les figures ci-dessous sont des exemples de câblage pour illustrer la façon de disposer les câbles d'alimentation et les conducteurs de terre de l'unité de base principale et des unités de base d'extension.

(1) Single power supply system

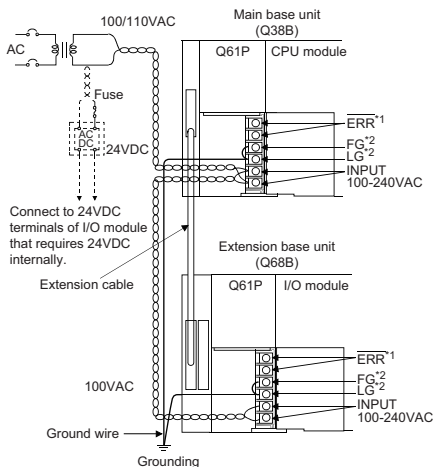

*1 The operation of the ERR terminal is as follows:

<When the power supply module is mounted on the main base unit>

The terminal turns off (opens) when the AC power is not input, a CPU module stop error (including a reset) occurs, or the fuse of the power supply module is blown.<When the power supply module is mounted on the extension base unit>
The terminal is always off (opened).

*2 Ground the LG and FG terminals by using a ground wire as thick and short as possible (2mm in diameter).

(1) Système à alimentation unique

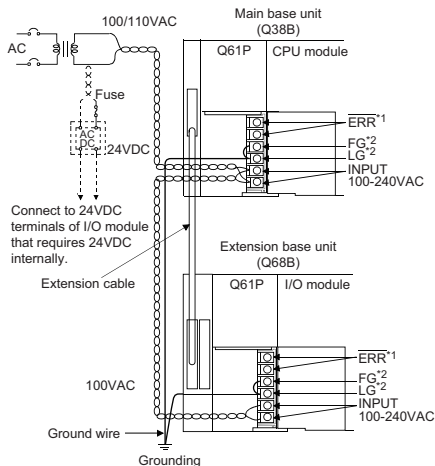

English	French
100/110VAC	100/110VAC
100VAC	100V ca
Connect to 24VDC terminals of I/O module that requires 24VDC internally.	Raccorder les bornes 24V cc du module d'entrée/sortie à alimentation interne 24V cc.
Extension base unit	Unité de base d'extension
Extension cable	Câble de rallonge
Fuse	Fusible
Ground wire	Fil de terre
Grounding	Mise à la terre
I/O module	Module d'entrée/sortie
Main base unit	Unité de base principale

*1 La borne ERR fonctionne comme suit :

<Avec module d'alimentation monté sur l'unité de base principale>

La borne est hors mise hors tension (ouverture du circuit) quand il n'y a pas d'alimentation en ca, à la survenance d'une erreur provoquant l'arrêt (ou la réinitialisation) du module CPU, ou quand le fusible d'alimentation a fondu. <Avec module d'alimentation monté sur une unité de base principale d'extension>

La borne est toujours hors tension (circuit ouvert)

*2 Mettre à la terre les bornes LG et FG en utilisant un gros fil de terre (section 2mm) le plus court possible.

(2) Redundant power supply system

• Q64RPN

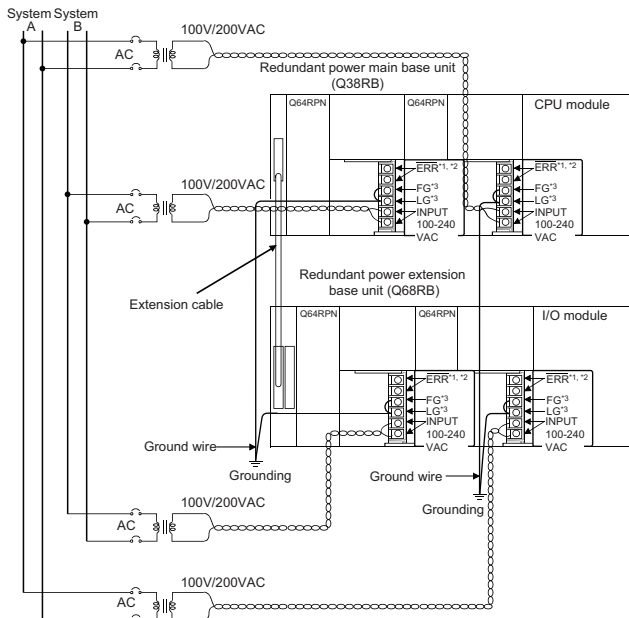

*1 The operation of the ERR terminal is as follows:

<When the redundant power supply module is mounted on the redundant power main base unit>

The terminal turns off (opens) when the AC power is not input, a CPU module stop error (including a reset) occurs, the redundant power supply module fails, or the fuse of the redundant power supply module is blown.

<When the redundant power supply module is mounted on the redundant power extension base unit>

The terminal turns off (opens) when the AC power is not input, the redundant power supply module fails, or the fuse of the redundant power supply module is blown.

*2 When input power is supplied to the redundant power supply module mounted on the redundant power main base unit and the redundant power supply module mounted on the redundant power extension base unit simultaneously, the ON (short) timing of the ERR terminal on the redundant power main base unit is later than that of the ERR terminal on the redundant power extension base unit by the initial processing time of the CPU module.

*3 Ground the LG and FG terminals by using a ground wire as thick and short as possible (2mm in diameter).

• Q64RP

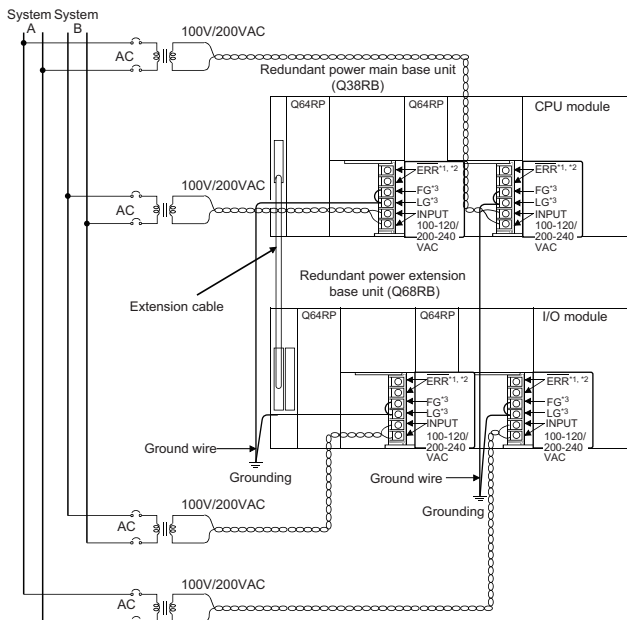

- *1 The operation of the ERR terminal is as follows:
 <When the redundant power supply module is mounted on the redundant power main base unit>
 The terminal turns off (opens) when the AC power is not input, a CPU module stop error (including a reset) occurs, the redundant power supply module fails, or the fuse of the redundant power supply module is blown.
 <When the redundant power supply module is mounted on the redundant power extension base unit>
 The terminal turns off (opens) when the AC power is not input, the redundant power supply module fails, or the fuse of the redundant power supply module is blown.
- *2 When input power is supplied to the redundant power supply module mounted on the redundant power main base unit and the redundant power supply module mounted on the redundant power extension base unit simultaneously, the ON (short) timing of the ERR terminal on the redundant power main base unit is later than that of the ERR terminal on the redundant power extension base unit by the initial processing time of the CPU module.
- *3 Ground the LG and FG terminals by using a ground wire as thick and short as possible (2mm in diameter).

(2) Système à alimentation redondante

• Q64RPN

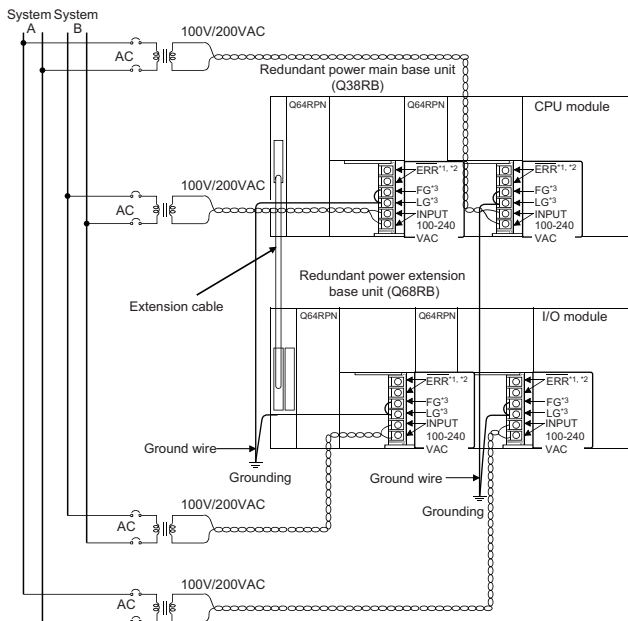

English	French
100V/200VAC	100V/200V ca
CPU module	Module CPU
Extension cable	Câble de rallonge
Ground wire	Fil de terre
Grounding	Mise à la terre
I/O module	Module d'entrée/sortie
Redundant power extension base unit	Unité de base d'extension à alimentation redondante
Redundant power main base unit	Unité de base principale à alimentation redondante
System A	Système A
System B	Système B

- *1 La borne ERR fonctionne comme suit :*
<Avec module d'alimentation redondante monté sur l'unité de base principale à alimentation redondante>
La borne est mise hors tension (ouverture du circuit) quand il n'y a pas d'alimentation en ca, à la survenance d'une erreur provoquant l'arrêt (ou la réinitialisation) du module CPU, en cas de défaillance du module d'alimentation redondante ou quand le fusible d'alimentation redondante a fondu.
<Avec module d'alimentation redondante monté sur une unité de base d'extension à alimentation redondante>
La borne est mise hors tension (ouverture du circuit) quand il n'y a pas d'alimentation en ca, en cas de défaillance du module d'alimentation redondante ou quand le fusible d'alimentation redondante a fondu.
- *2 Quand les modules d'alimentation montés sur les unités de base principale et d'extension à alimentation redondante sont tous deux sous tension, la borne ERR de l'unité de base principale à alimentation redondante passe ON (court) après la borne ERR de l'unité de base d'extension à alimentation redondante, avec un décalage de temps correspondant à la durée d'initialisation du module CPU.*
- *3 Mettre à la terre les bornes LG et FG en utilisant un gros fil de terre (section 2mm) le plus court possible.*

• Q64RP

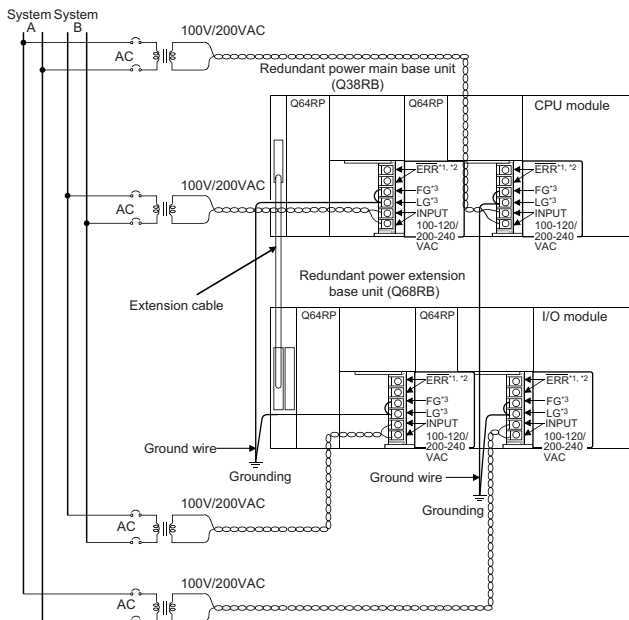

English	French
100V/200VAC	100V/200V ca
CPU module	Module CPU
Extension cable	Câble de rallonge
Ground wire	Fil de terre
Grounding	Mise à la terre
I/O module	Module d'entrée/sortie
Redundant power extension base unit	Unité de base d'extension à alimentation redondante
Redundant power main base unit	Unité de base principale à alimentation redondante
System A	Système A
System B	Système B

- *1 La borne ERR fonctionne comme suit :*
<Avec module d'alimentation redondante monté sur l'unité de base principale à alimentation redondante>
La borne est mise hors tension (ouverture du circuit) quand il n'y a pas d'alimentation en ca, à la survenance d'une erreur provoquant l'arrêt (ou la réinitialisation) du module CPU, en cas de défaillance du module d'alimentation redondante ou quand le fusible d'alimentation redondante a fondu.
<Avec module d'alimentation redondante monté sur une unité de base d'extension à alimentation redondante>
La borne est mise hors tension (ouverture du circuit) quand il n'y a pas d'alimentation en ca, en cas de défaillance du module d'alimentation redondante ou quand le fusible d'alimentation redondante a fondu.
- *2 Quand les modules d'alimentation montés sur les unités de base principale et d'extension à alimentation redondante sont tous deux sous tension, la borne ERR de l'unité de base principale à alimentation redondante passe ON (court) après la borne ERR de l'unité de base d'extension à alimentation redondante, avec un décalage de temps correspondant à la durée d'initialisation du module CPU.*
- *3 Mettre à la terre les bornes LG et FG en utilisant un gros fil de terre (section 2mm) le plus court possible.*

5.3 Connection diagram of the input/output module

Schéma des connexions du module d'entrée/sortie

(1) Input modules

Modules d'entrée

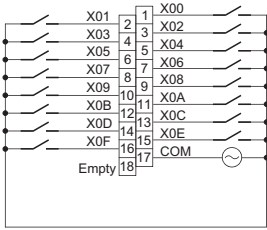
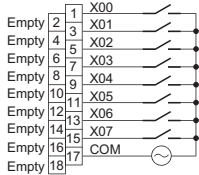
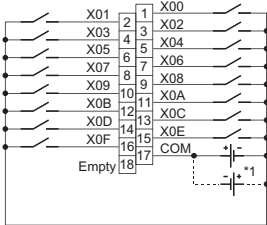
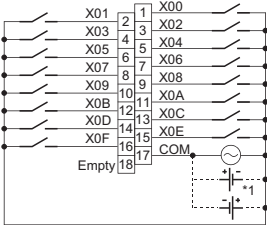
<p style="text-align: center;">QX10, QX10-TS (Rated input voltage: 100 to 120VAC) (Tension nominale d'entrée 100 à 120 V ca)</p> 	<p style="text-align: center;">QX28 (Rated input voltage: 100 to 240VAC) (Tension nominale d'entrée 100 à 240 V ca)</p> 
<p style="text-align: center;">QX40, QX40-S1, QX40-TS (Rated input voltage: 24VDC) (Tension nominale d'entrée 24 V cc) QX70 (Rated input voltage: 5/12VDC) (Tension nominale d'entrée 5/12 V cc)</p>	<p style="text-align: center;">QX50 (Rated input voltage: 48VDC/AC) (Tension nominale d'entrée 48 V cc/ca)</p>
 <p>*1 Positive and negative commons are both available for QX70. *1 Pour les QX70, des communs sont disponibles en positif comme en négatif.</p>	 <p>*1 Positive and negative commons are both available for DC input. *1 Pour les entrées cc, des communs sont disponibles en positif comme en négatif.</p>
<p style="text-align: center;">English</p>	<p style="text-align: center;">French</p>
<p>Empty</p>	<p>Inutilisé</p>

QX80, QX80-TS
 (Rated input voltage: 24VDC)
 (*Tension nominale d'entrée 24 V cc*)

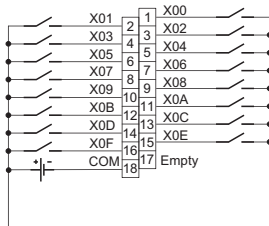

QX40H
 (Rated input voltage: 24VDC)
 (*Tension nominale d'entrée 24 V cc*)

QX70H
 (Rated input voltage: 5VDC)
 (*Tension nominale d'entrée 5 V cc*)

QX80H
 (Rated input voltage: 24VDC)
 (*Tension nominale d'entrée 24 V cc*)

QX90H
 (Rated input voltage: 5VDC)
 (*Tension nominale d'entrée 5 V cc*)

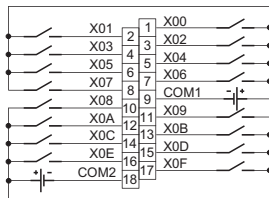
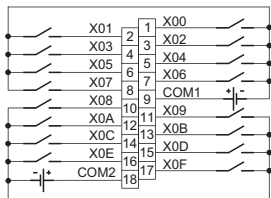

English

French

Empty

Inutilisé

QX41, QX41-S1, QX41-S2, QX42^{*1}, QX42-S1^{*1}
 (Rated input voltage: 24VDC)
 (Tension nominale d'entrée 24 V cc)
 QX71, QX72^{*1}
 (Rated input voltage: 5/12VDC)
 (Tension nominale d'entrée 5/12 V cc)

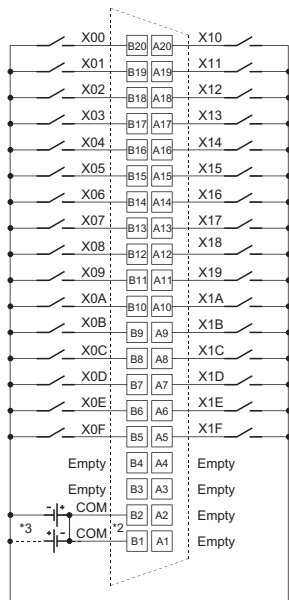

*1 For the QX42/QX42-S1/QX72, the above diagram shows the first half 32 points (F). The connections of the latter half 32 points (L) are the same as those of the first half 32 points (F).

Regard X00 to X1F as X20 to X3F.

*2 [B1] and [B2] are connected internally.

*3 Negative and positive commons are both available for QX71 and QX72.

*1 Pour les QX42/QX42-S1/QX72, le schéma ci-dessus ne présente que la première moitié de 32 points (F). Les raccordements de la seconde moitié de 32 points (L) sont identiques à ceux de la première moitié de 32 points (F).

Considérer X00 à X1F comme étant X20 à X3F.

*2 [B1] et [B2] sont connectés à l'intérieur.

*3 Pour les QX71 et QX72, des communs sont disponibles en positif comme en négatif.

English	French
Empty	Inutilisé

QX81, QX81-S2
(Rated input voltage: 24VDC)
(Tension nominale d'entrée 24 V cc)

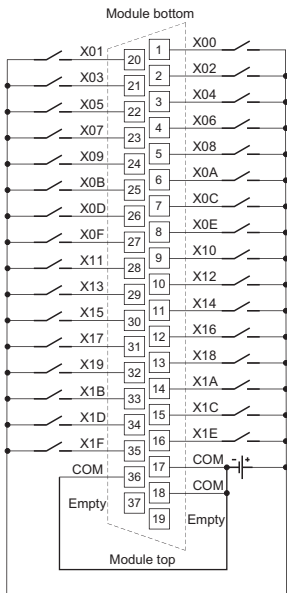

*1 [17], [18] and [36] are connected internally.

*1 [17], [18] et [36] sont connectés à l'intérieur.

QX82¹, QX82-S1¹
(Rated input voltage: 24VDC)
(Tension nominale d'entrée 24 V cc)

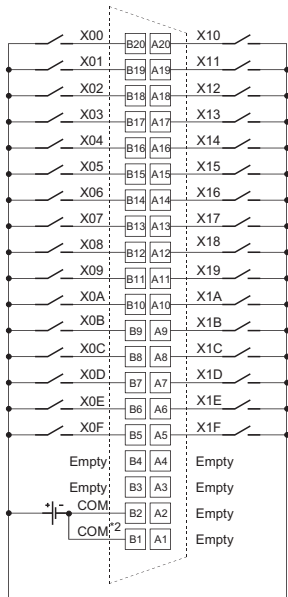

*1 The above diagram shows the first half 32 points (F).

The connections of the latter half 32 points (L) are the same as those of the first half 32 points (F).

Regard X00 to X1F as X20 to X3F.

*2 [B1] and [B2] are connected internally.

*1 Le schéma ci-dessus représente la première moitié de 32 points (F). Les raccordements de la seconde moitié de 32 points (L) sont identiques à ceux de la première moitié de 32 points (F).. Considérer X00 à X1F comme étant X20 à X3F.

*2 [B1] et [B2] sont connectés à l'intérieur.

English	French	English	French
Module bottom	<i>Fond du module</i>	Empty	<i>Inutilisé</i>
Module top	<i>Partie supérieure du module</i>		

(2) Output modules *Modules de sortie*

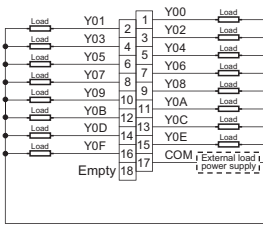
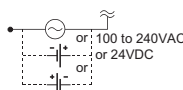
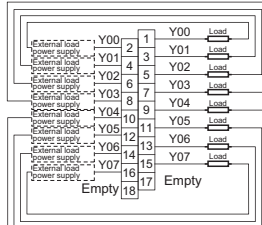
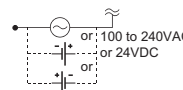
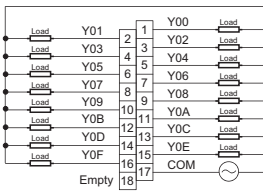
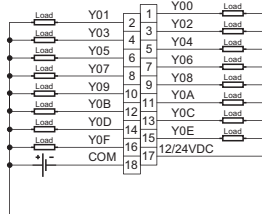
<p>QY10, QY10-TS (Rated load voltage: 24VDC/ 240VAC) (<i>Tension nominale d'entrée 24V cc/240V ca</i>)</p>  <p>*1 The following diagram shows the external load power supply. *1 <i>Schéma d'alimentation de la charge externe :</i></p> 	<p>QY18A (Rated load voltage: 24VDC/ 240VAC) (<i>Tension nominale d'entrée 24V cc/240V ca</i>)</p>  <p>*1 The following diagram shows the external load power supply. *1 <i>Schéma d'alimentation de la charge externe :</i></p> 
<p>QY22 (Rated load voltage: 100-240VAC) (<i>Tension nominale d'entrée 100-240 V cc</i>)</p> 	<p>QY40P, QY40P-TS (Rated load voltage: 12/24VDC) (<i>Tension nominale d'entrée 12/24 V cc</i>)</p> 

English	French	English	French
Load	<i>Charge</i>	External load power supply	<i>Alimentation charge externe</i>
Empty	<i>Inutilisé</i>	100 to 240 VAC or 24VDC	<i>100 à 240 V ca ou 24V cc</i>

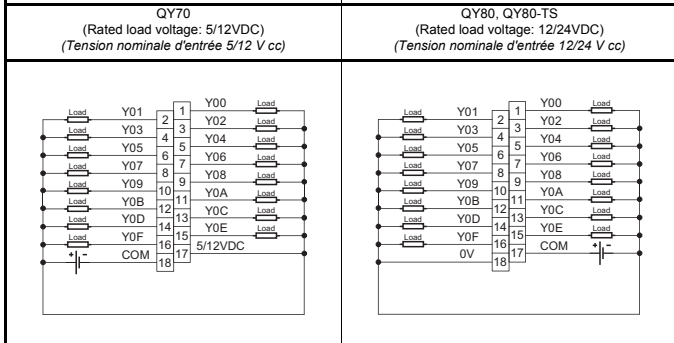
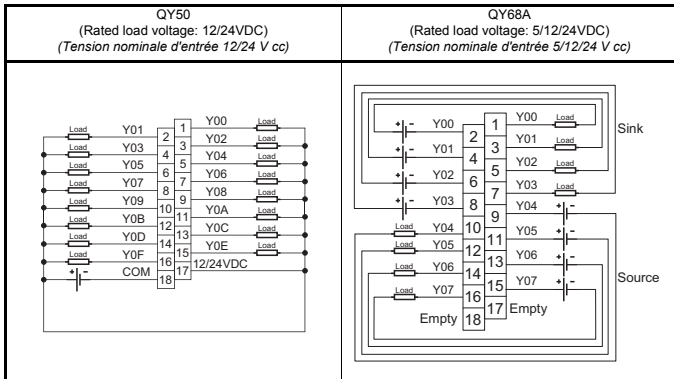

English	French	English	French
Load	Charge	Sink	Dissipateur
Empty	Inutilisé	Source	Source

QY41H
(Rated load voltage: 5 to 24VDC)
(Tension nominale d'entrée 5 à 24 V ca)

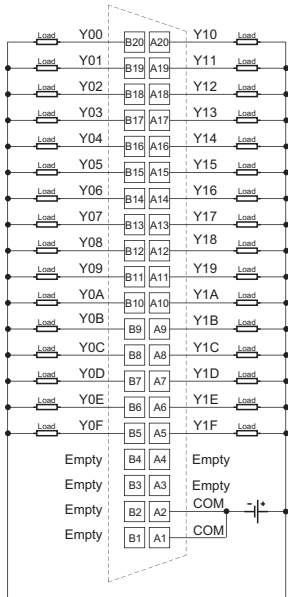

QY41P, QY42P
(Rated load voltage: 12/24VDC)
(Tension nominale d'entrée 12/24 V cc)

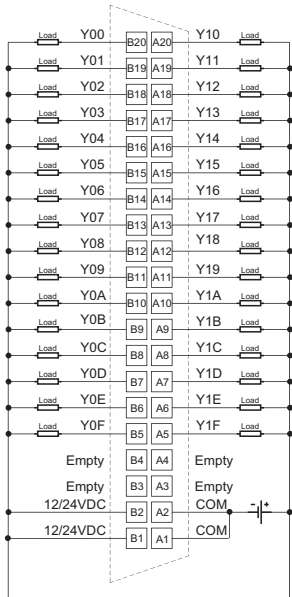

*1 [A1] and [A2] are internally connected.

*1 [A1] et [A2] sont connectés à l'intérieur.

*1 For QY42P, the above diagram shows the first half 32 points (F).

The connections of the latter half 32 points (L) are the same as those of the first half 32 points (F).
Regard Y00 to Y1F as Y20 to Y3F.

*2 [B1] and [B2], and [A1] and [A2] are internally connected.

*1 Pour QY42P, le diagramme ci-dessus présente la première moitié de 32 points (F).

Les raccordements de la seconde moitié de 32 points (L) sont identiques à ceux de la première moitié de 32 points (F).
Considérer X00 à X1F comme étant Y20 à Y3F.

*2 [B1] et [B2], ainsi que [A1] et [A2], sont connectés à l'intérieur.

English	French	English	French
Load	Charge	Empty	Inutilisé

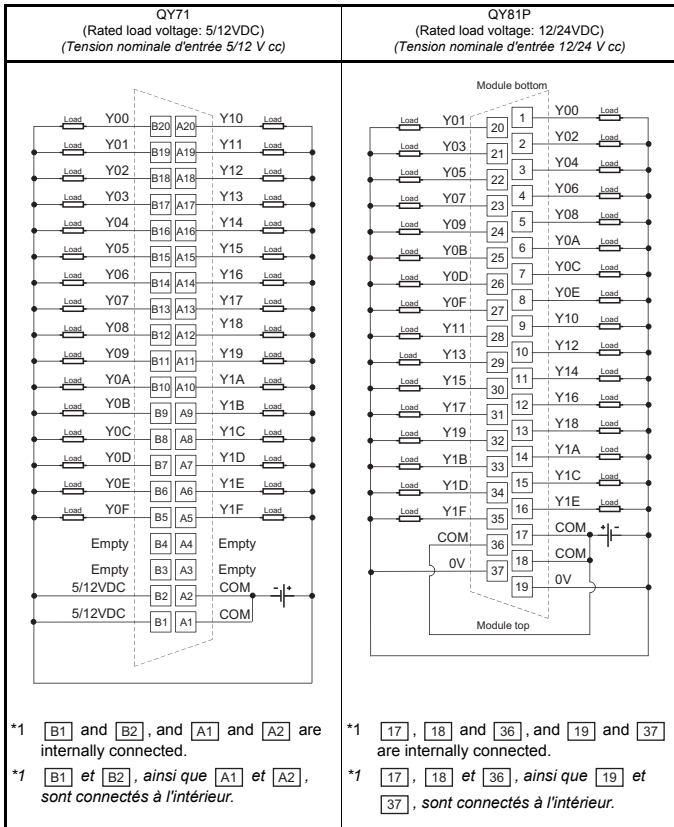

QY82P
 (Rated load voltage: 12/24VDC)
 (Tension nominale d'entrée 12/24 V cc)

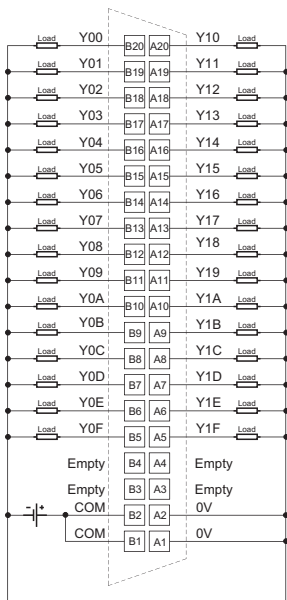

- *1 For QY82P, the above diagram shows the first half 32 points (F).
 The connections of the latter half 32 points (L) are the same as those of the first half 32 points (F).
 Regard Y00 to Y1F as Y20 to Y3F.
- *2 **B1** and **B2**, and **A1** and **A2** are internally connected.
- *1 *Pour QY82P, le diagramme ci-dessus présente la première moitié de 32 points (F).
 Les raccordements de la seconde moitié de 32 points (L) sont identiques à ceux de la première moitié de 32 points (F).
 Considérer X00 à X1F comme étant Y20 à Y3F.*
- *2 **B1** et **B2**, ainsi que **A1** et **A2**, sont connectés à l'intérieur.

English	French	English	French
Load	Charge	Empty	Inutilisé

(3) Input/output combined modules
Modules combinés entrée/sortie

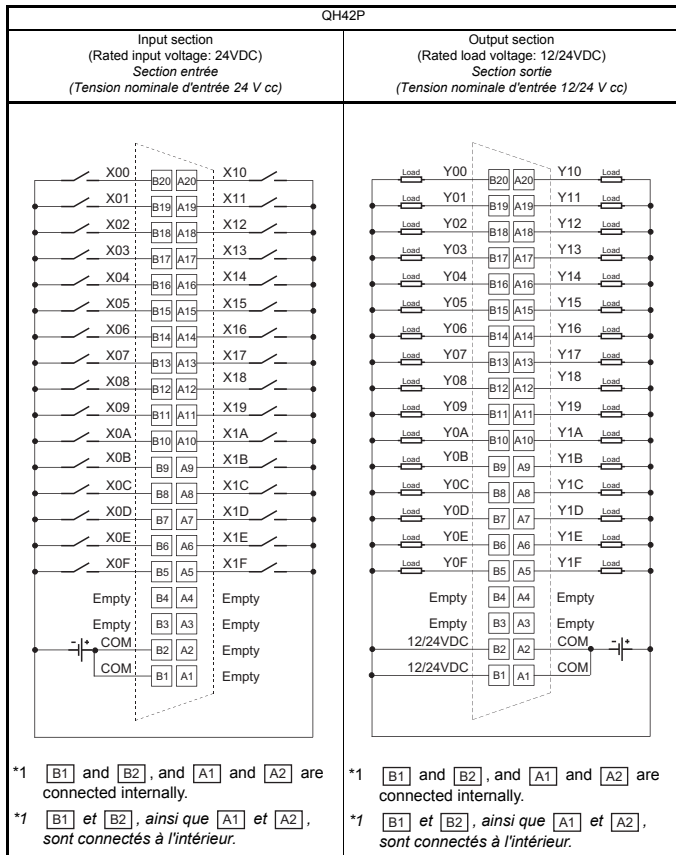

English	French	English	French
Load	Charge	Empty	Inutilisé

Input section
(Rated input voltage: 24VDC)
Section entrée
(Tension nominale d'entrée 24 V cc)

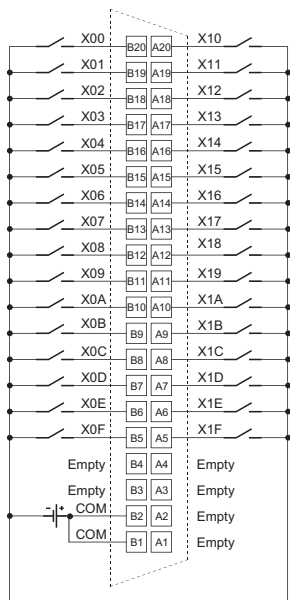

*1 [B1] and [B2], and [A1] and [A2] are connected internally.

*1 [B1] et [B2], ainsi que [A1] et [A2], sont connectés à l'intérieur.

Output section
(Rated load voltage: 12/24VDC)
Section sortie
(Tension nominale d'entrée 12/24 V cc)

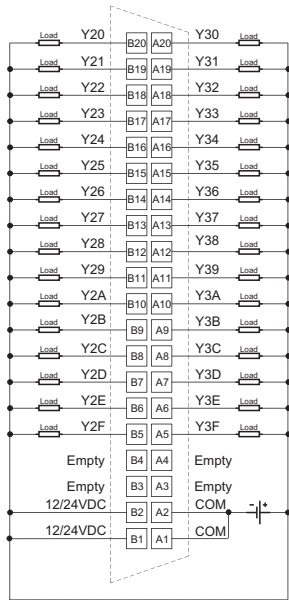

*1 [B1] and [B2], and [A1] and [A2] are connected internally.

*1 [B1] et [B2], ainsi que [A1] et [A2], sont connectés à l'intérieur.

English	French	English	French
Load	Charge	Empty	Inutilisé

QX48Y57

(Rated input voltage: 24VDC, Rated load voltage: 12/24VDC)

(Tension nominale d'entrée 24 V cc, Tension nominale de charge : 12/24 V cc)

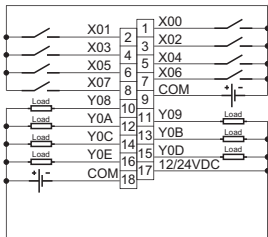

English

French

Load

Charge

(4) Interrupt module
Module d'interruptions

QI60

(Rated input voltage: 24VDC)

(Tension nominale d'entrée 24 V cc)

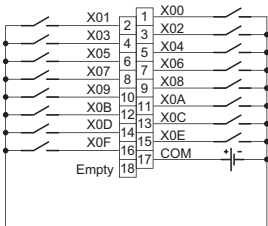

English

French

Empty

Inutilisé

5.4 Wiring a terminal block

Câblage d'une plaque à bornes

The table below shows applicable solderless terminals connected to the terminal block. When wiring, use applicable wires and an appropriate tightening torque.

Use UL-listed solderless terminals and, for processing, use a tool recommended by their manufacturer. Also, sleeved solderless terminals cannot be used.

It is recommended to cover the wire connections of the solderless terminals with mark or insulation tubes.

Solderless terminal		Wire			
Model	Tightening torque	Diameter	Type	Material	Temperature rating
R1.25-3	0.42 to 0.58N·m	22 to 18 AWG	Stranded	Copper	75°C or more

Le tableau ci-dessous indique quelles bornes sans soudure on doit utiliser pour les raccordements sur la plaque à bornes.

Pour le câblage, utiliser les fils et couples de serrage prescrits. Utiliser les bornes sans soudure répertoriées par UL et, pour le montage, utiliser l'outil recommandé par le fabricant de ces bornes.

En outre, il ne faut pas utiliser de bornes sans soudure sous manchon. Il est recommandé de protéger les bornes soudées des connexions par fils avec des manchons isolants avec marquage.

Borne sans soudure		Fil			
Modèle	Couple de serrage	Diamètre	Type	Matériau	Gamme de température
R1.25-3	0.42 à 0.58N·m	22 à 18 AWG	Torsadé	Cuivre	75 °C ou plus

5.5 Replacement Procedure of the Q6BAT Battery

5.5.1 Basic model QCPU

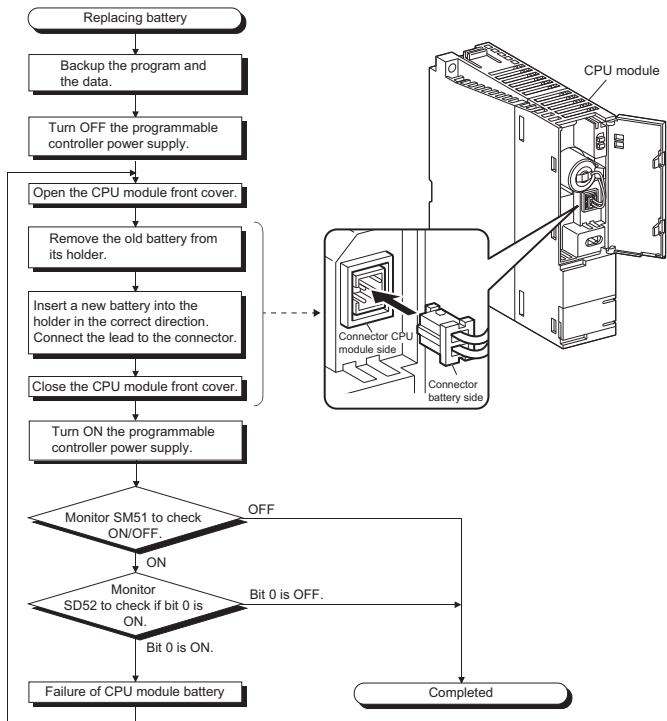

5.5.2 High Performance model QCPU, Process CPU, Redundant CPU and Universal model QCPU

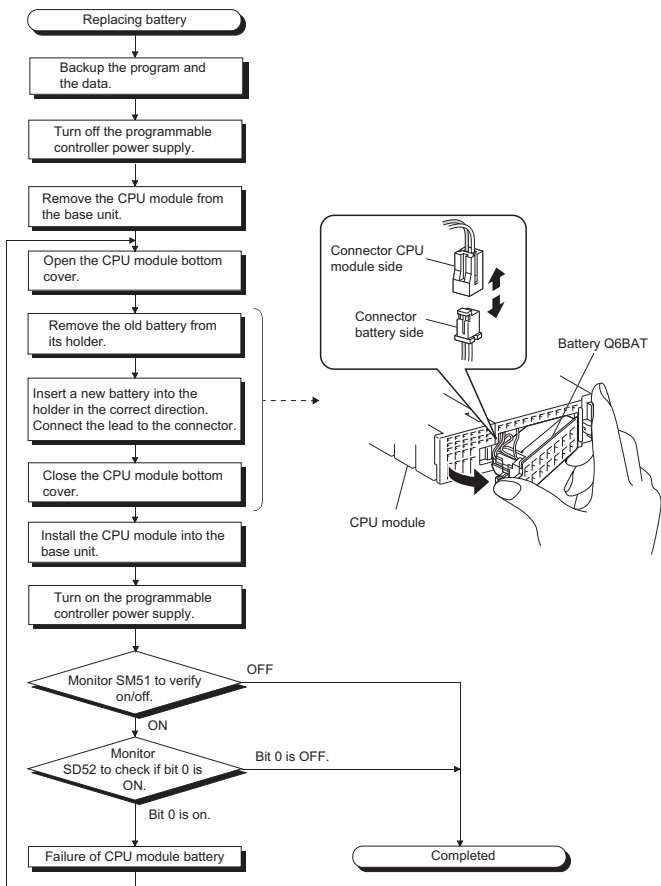

WARRANTY

Please confirm the following product warranty details before using this product.

1. Gratis Warranty Term and Gratis Warranty Range

If any faults or defects (hereinafter "Failure") found to be the responsibility of Mitsubishi occurs during use of the product within the gratis warranty term, the product shall be repaired at no cost via the sales representative or Mitsubishi Service Company.

However, if repairs are required onsite at domestic or overseas location, expenses to send an engineer will be solely at the customer's discretion. Mitsubishi shall not be held responsible for any re-commissioning, maintenance, or testing on-site that involves replacement of the failed module.

[Gratis Warranty Term]

The gratis warranty term of the product shall be for one year after the date of purchase or delivery to a designated place.

Note that after manufacture and shipment from Mitsubishi, the maximum distribution period shall be six (6) months, and the longest gratis warranty term after manufacturing shall be eighteen (18) months. The gratis warranty term of repair parts shall not exceed the gratis warranty term before repairs.

[Gratis Warranty Range]

- (1) The range shall be limited to normal use within the usage state, usage methods and usage environment, etc., which follow the conditions and precautions, etc., given in the instruction manual, user's manual and caution labels on the product.
- (2) Even within the gratis warranty term, repairs shall be charged for in the following cases.
 1. Failure occurring from inappropriate storage or handling, carelessness or negligence by the user. Failure caused by the user's hardware or software design.
 2. Failure caused by unapproved modifications, etc., to the product by the user.
 3. When the Mitsubishi product is assembled into a user's device, Failure that could have been avoided if functions or structures, judged as necessary in the legal safety measures the user's device is subject to or as necessary by industry standards, had been provided.
 4. Failure that could have been avoided if consumable parts (battery, backlight, fuse, etc.) designated in the instruction manual had been correctly serviced or replaced.
 5. Failure caused by external irresistible forces such as fires or abnormal voltages, and Failure caused by force majeure such as earthquakes, lightning, wind and water damage.
 6. Failure caused by reasons unpredictable by scientific technology standards at time of shipment from Mitsubishi.
 7. Any other failure found not to be the responsibility of Mitsubishi or that admitted not to be so by the user.

2. Onerous repair term after discontinuation of production

(1) Mitsubishi shall accept onerous product repairs for seven (7) years after production of the product is discontinued. Discontinuation of production shall be notified with Mitsubishi Technical Bulletins, etc.

(2) Product supply (including repair parts) is not available after production is discontinued.

3. Overseas service

Overseas, repairs shall be accepted by Mitsubishi's local overseas FA Center. Note that the repair conditions at each FA Center may differ.

4. Exclusion of loss in opportunity and secondary loss from warranty liability

Regardless of the gratis warranty term, Mitsubishi shall not be liable for compensation to:

- (1) Damages caused by any cause found not to be the responsibility of Mitsubishi.
- (2) Loss in opportunity, lost profits incurred to the user by Failures of Mitsubishi products.
- (3) Special damages and secondary damages whether foreseeable or not, compensation for accidents, and compensation for damages to products other than Mitsubishi products.
- (4) Replacement by the user, maintenance of on-site equipment, start-up test run and other tasks.

5. Changes in product specifications

The specifications given in the catalogs, manuals or technical documents are subject to change without prior notice.

Ethernet is a registered trademark of Fuji Xerox Co., Ltd. in Japan.
CompactFlash and its logo are either trademarks or registered trademarks of SanDisk Corporation in the United States and other countries.
MODBUS is a registered trademark of SCHNEIDER ELECTRIC USA, INC.
The company names, system names and product names mentioned in this manual are either registered trademarks or trademarks of their respective companies.
In some cases, trademark symbols such as TM or [®] are not specified in this manual.

Country/ Region	Sales office/ Tel	Country/ Region	Sales office/ Tel
USA	MITSUBISHI ELECTRIC AUTOMATION, INC. 500 Corporate Woods Parkway, Vernon Hills, IL 60061, U.S.A. Tel : +1-847-478-2100	Turkey	MITSUBISHI ELECTRIC TURKEY A.Ş. Ümraniye Branch Serifali Mahallesi Nutuk Sokak No:5, TR-34775 Ümraniye/Istanbul, Turkey Tel : +90-216-526-3990
Mexico	MITSUBISHI ELECTRIC AUTOMATION, INC. Mexico Branch Mariano Escobedo #69, Col. Zona Industrial, Tlalpanpanita Edo. Mexico, C.P.54030 Tel : +52-55-3067-7500	UAE	MITSUBISHI ELECTRIC EUROPE B.V. Dubai Branch Dubai Silicon Oasis, P.O.BOX 341241, Dubai, U.A.E. Tel : +971-4-3724716
Brazil	MITSUBISHI ELECTRIC DO BRASIL COMÉRCIO E SERVIÇOS LTDA. Avenida Adelino Cardana, 293, 21 andar, Bethaville, Barueri SP, Brazil Tel : +55-11-4689-3000	South Africa	ADROIT TECHNOLOGIES 20 Waterford Office Park, 189 Witkoppen Road, Fourways, South Africa Tel : +27-11-658-8100
Germany	MITSUBISHI ELECTRIC EUROPE B.V. German Branch Mitsubishi-Electric-Platz 1, 40882 Ratingen, Germany Tel : +49-2102-486-0	China	MITSUBISHI ELECTRIC AUTOMATION (CHINA) LTD. No.1386 Hongqiao Road, Mitsubishi Electric Automation Center, Shanghai, China Tel : +86-21-2322-3030
UK	MITSUBISHI ELECTRIC EUROPE B.V. UK Branch Travellers Lane, Hatfield, Hertfordshire, AL10 8XB, U.K. Tel : +44-1707-28-8780	Taiwan	SETSUYO ENTERPRISE CO., LTD. 6F, No.105, Wugong 3rd Road, Wugu District, New Taipei City 24889, Taiwan Tel : +886-2-2299-2499
Ireland	MITSUBISHI ELECTRIC EUROPE B.V. Irish Branch Westgate Business Park, Ballymount, Dublin 24, Ireland Tel : +353-1-4198800	Korea	MITSUBISHI ELECTRIC AUTOMATION KOREA CO., LTD. 7F-9F, Gangseo Hangang Xi-tower A, 401, Yangcheon-ro, Gangseo-Gu, Seoul 07528, Korea Tel : +82-2-3660-9530
Italy	MITSUBISHI ELECTRIC EUROPE B.V. Italian Branch Centro Direzionale Colleoni-Palazzo Sirio Viale Colleoni 7, 20864 Agrate Brianza(Milano) Italy Tel : +39-039-60531	Singapore	MITSUBISHI ELECTRIC ASIA PTE. LTD. 307, Alexandra Road, Mitsubishi Electric Building, Singapore 159943 Tel : +65-6473-2308
Spain	MITSUBISHI ELECTRIC EUROPE, B.V. Spanish Branch Carretera de Rubi, 76-80-Apdo. 420, 08190 Sant Cugat del Vallés (Barcelona), Spain Tel : +34-935-65-3131	Thailand	MITSUBISHI ELECTRIC FACTORY AUTOMATION (THAILAND) CO., LTD. 12th Floor, SV City Building, Office Tower 1, No. 896/19 and 20 Rama 3 Road, Kwaeng Bangpangpang, Khet Yannawa, Bangkok 10120, Thailand Tel : +66-2682-6522
France	MITSUBISHI ELECTRIC EUROPE B.V. French Branch 25, Boulevard des Bouvets, 92741 Nanterre Cedex, France Tel : +33-1-55-68-55-68	Vietnam	MITSUBISHI ELECTRIC VIETNAM COMPANY LIMITED Hanoi Branch 6th Floor, Detch Tower, 8 Ton That Thuyet Street, My Dinh 2 Ward, Nam Tu Liem District, Hanoi, Vietnam Tel : +84-4-3937-8075
Czech Republic	MITSUBISHI ELECTRIC EUROPE B.V. Czech Branch Avenir Business Park, Radlicka 751/113e, 158 00 Praha5, Czech Republic Tel : +420-251-551-470	Indonesia	PT. MITSUBISHI ELECTRIC INDONESIA Gedung Jaya 11th Floor, J.L. MH. Thamrin No.12, Jakarta Pusat 10340, Indonesia Tel : +62-21-3192-6461
Poland	MITSUBISHI ELECTRIC EUROPE B.V. Polish Branch ul. Krakowska 50, 32-083 Balice, Poland Tel : +48-12-347-65-00	India	MITSUBISHI ELECTRIC INDIA PVT. LTD. Pune Branch Emerald House, EL-3, J Block, M.I.D.C., Bhosari, Pune-411026, Maharashtra, India Tel : +91-20-2710-2000
Sweden	MITSUBISHI ELECTRIC EUROPE B.V. (Scandinavia) Fjellevägen 8, SE-22736 Lund, Sweden Tel : +46-8-625-10-00	Australia	MITSUBISHI ELECTRIC AUSTRALIA PTY. LTD. 348 Victoria Road, P.O. Box 11, Rydalmere, N.S.W 2116, Australia Tel : +61-2-9684-7777
Russia	MITSUBISHI ELECTRIC (RUSSIA) LLC St. Petersburg Branch Piskarevsky pr. 2, bld 2, lit "Sch", BC "Benua", office 720; 195027 St. Petersburg, Russia Tel : +7-812-633-3497		

MITSUBISHI ELECTRIC CORPORATION

HEAD OFFICE : TOKYO BUILDING, 2-7-3 MARUNOUCHI, CHIYODA-KU, TOKYO 100-8310, JAPAN
NAGOYA WORKS : 1-14, YADA-MINAMI 5-CHOME, HIGASHI-KU, NAGOYA, JAPAN

When exported from Japan, this manual does not require application to the Ministry of Economy,
Trade and Industry for service transaction permission.

Specifications subject to change without notice.