

Series E3.22 | Zip-open along outer radius

| e-chain® zip-open along outer radius | <i>Bi</i> [mm] | <i>Ba</i> [mm] | <i>R</i> Bending radii [mm] | Weight [kg/m] |
|--------------------------------------|-------------------|-------------------|--------------------------------|------------------|
| E3.22. 020 .R.0 | 20 | 32 | 044 050 075 | ≈ 0,30 |
| E3.22. 040 .R.0 | 40 | 52 | 044 050 075 | ≈ 0,32 |
| E3.22. 060 .R.0 | 60 | 72 | 044 - 075 | ≈ 0,41 |

Supplement Part No. with required radius (*R*). Example: **E3.22.060.044.0**

Dimensions

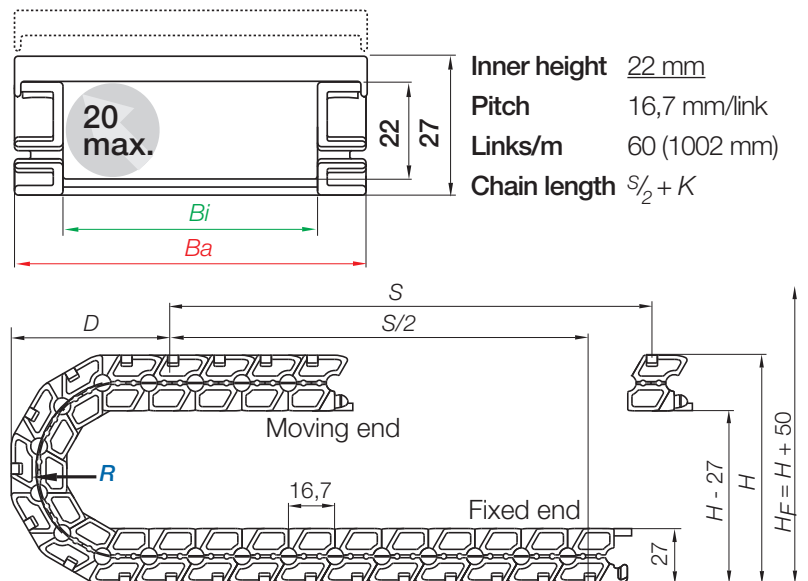
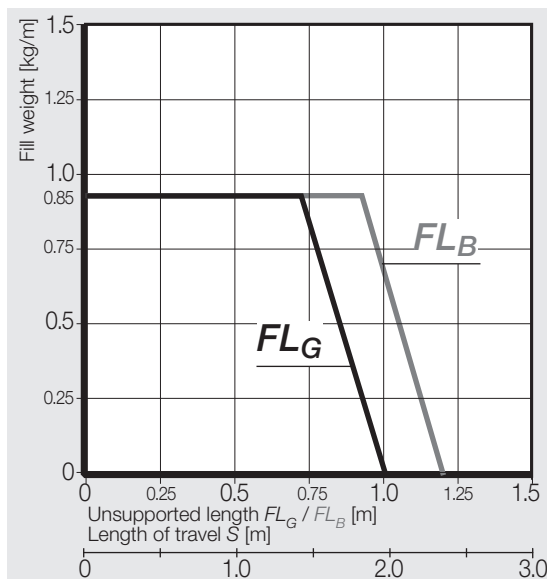

| <i>R</i> | 044 | 050 | 075 |
|----------|-----|-----|-----|
| <i>H</i> | 134 | 146 | 196 |
| <i>D</i> | 82 | 88 | 113 |
| <i>K</i> | 175 | 195 | 270 |

The required clearance height: $H_F = H + 50$ mm (with 0,3 kg/m fill weight)

KMA mounting bracket | Mounting angle | polymer

Fixed end
E3.22.....2

View mounting angle

Moving end
E3.22...1

View KMA mounting bracket

E3.150.220.12 - Space-saving allround KMA mounting brackets

| Width Index | Part No. space-saving all-round KMA mounting bracket | Dim. A [mm] | Dim. B [mm] | Part No. full set mounting angle (single part) | Part No. strain relief for both sides | Part No. full set strain relief for both sides + 2 mounting angles* |
|-------------|--|-------------|-------------|--|---------------------------------------|---|
| .020. | ▶ E3.220.020.12 | 28 | 36 | E3.22.00 | E3.020.12 | E3.22.020.12 |
| .040. | ▶ E3.220.040.12 | 48 | 56 | E3.22.00 | E3.040.12 | E3.22.040.12 |
| .060. | ▶ E3.220.060.12 | 68 | 76 | E3.22.00 | E3.060.12 | E3.22.060.12 |

* Note: If the mounting brackets are used, two links each side must be added to the e-chain® length calculation, because the first two links are fixed by the mounting brackets.

E3.22.XXX.12 - E3 with strain relief for both sides and mounting angles

E3.00.020 - Strain relief for both sides as single parts

E3.22.00 - Mounting angle, single part

Possible installation conditions for mounting brackets.

Part No. structure

E3.22.060.12



Interior separation

Slotted separator for e-chains®

unassembled **E3.22.01**

assembled **E3.22.11**

Slotted separator E3.22.01

Vertical separators are used if a vertical subdivision of the e-chain® interior is required.