



## Product Datasheet

ENGLISH

# Anti-Vandal Switch

## Switch Pushbutton Stainless Latching

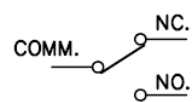
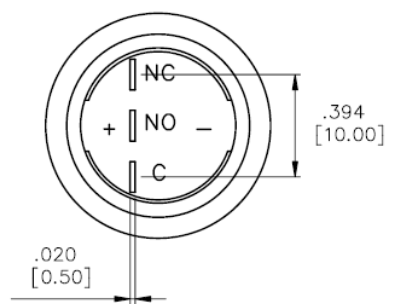
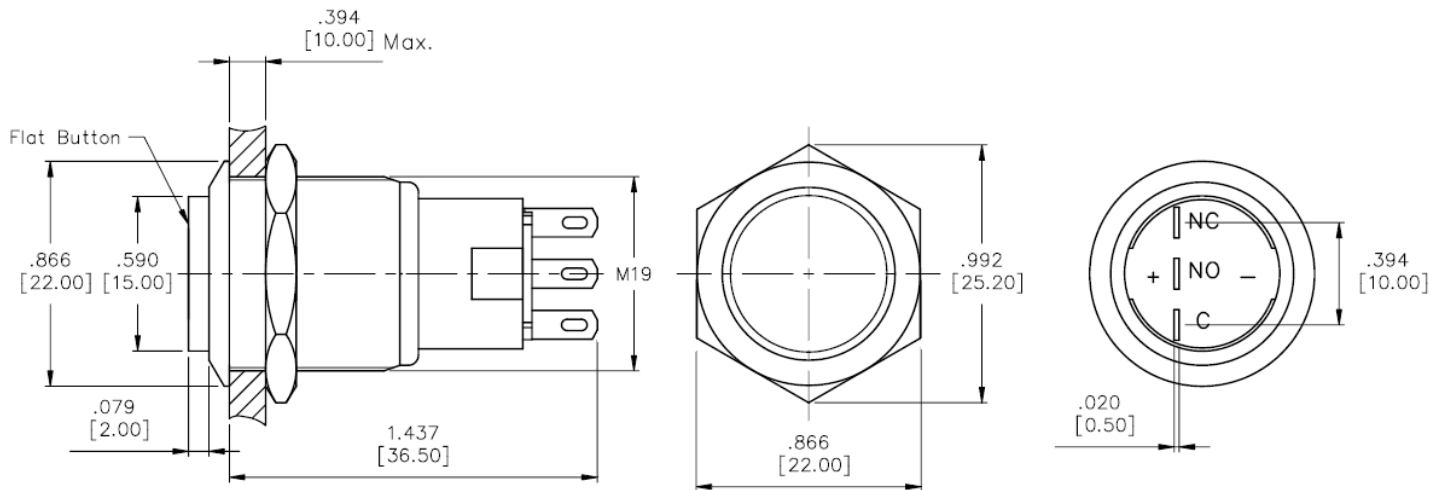

CONTACT CONFIGURATION





**Package Contain:**

- 1 x Anti-Vandal Switch
- 1 x Hex Nuts
- 1 x O-Ring

**Specification:**

<b>SWITCH TYPE:</b>		<b>8118566</b>
<b>POLES/THROWS:</b>		<b>SPDT</b>
<b>SWITCH FUNCTIONS:</b>		<b>ON-ON</b>
<b>ELECTRICAL CHARACTERISTICS</b>	<b>CONTACT RATING:</b>	<b>MAX. 5Amps @ 250VAC</b>
	<b>ELECTRICAL LIFE:</b>	<b>50,000 make-and-break cycles at full load</b>
	<b>CONTACT RESISTANCE:</b>	<b>50m-ohms max. initial @ 2-4VDC, 100mA</b>
	<b>INSULATION RESISTANCE:</b>	<b>Apply 500VDC for 1min±5sec. After which measurement to be made b/w terminals shall result 1000M-ohms min.</b>
	<b>DIELECTRICAL STRENGTH:</b>	<b>2,000VAC (50Hz-60Hz) RMS @ sea level shall result no damage to parts arcing or flashover</b>
	<b>OPERATING TEMPERATURE:</b>	<b>-20Celsius degree to +55Celsius degree</b>
<b>RELAIBILITY PERFORMANCE</b>	<b>MECHANICAL LIFE:</b>	<b>Without load, 50,000cycles min.</b>
	<b>OPERATING FORCE:</b>	<b>4N max.</b>
	<b>TORQUE:</b>	<b>5~14Nm max. applied to nut</b>
	<b>IP PROTECTION CLASS:</b>	<b>Front panel protection to IP67</b>
	<b>SOLDERING HEAT RESISTANCE:</b>	<b>Max soldering temperature @ 260Celsius degree, immersion time 5+/-1sec, frequency of soldering process @ 2 times max.</b>
	<b>COLD TEST:</b>	<b>Stored at temperature -20(+/-3)Celsius degree for 48 hours, shall result no changes to switch's electrical performance</b>
	<b>HOT TEST:</b>	<b>Stored at temperature +55(+/-3)Celsius degree for 48 hours, shall result no changes to switch's electrical performance</b>
	<b>HUMIDITY TEST:</b>	<b>Stored at temperature 40(+/-3)Celsius degree with relative humidity 90%~95% for 48 hours, shall result no changes to switch's electrical performance</b>
	<b>TORQUE:</b>	<b>5~14Nm max. applied to nut</b>
	<b>OPERATING FORCE:</b>	<b>4N max.</b>



<b>MATERIAL CHARACTERISTICS</b>	<b>BUTTON:</b>	<b>B12 : Stain less steel with varnished polished</b>	
	<b>BUSHING:</b>		
	<b>BASE:</b>		<b>PBT</b>
	<b>PLUNGER:</b>		<b>POM</b>
	<b>SPRING:</b>		<b>Steel wire</b>
	<b>CONTACT:</b>		<b>Copper alloy, silver plated</b>
	<b>TERMINALS:</b>		<b>Brass, silver plated</b>
	<b>HARDWARE:</b>		<b>Nut (Brass, nickel plated)</b>
<b>SOLDERING &amp; CLEANING RECOMMENDATION</b>	<b>HAND SOLDERING:</b>	<b>Max. temperature @ 320Celsius degree (662F)with continuous soldering time @ 2sec. max.</b>	
	<b>CLEANING PROCESS:</b>	<b>Noted, the switch is "not totally sealed" so it is important not to immerse/spray or clean unsealed areas of the switch during flux removal. Improper cleaning could cause switch deficiencies such as intermittence or open contact failures</b>	
<b>PACKAGE</b>	<b>INTERNAL PACKAGING:</b>	<b>1pcs per PE bag</b>	
	<b>RoHS IDENTIFI-CATIONS:</b>	<b>A label marking "RoHS compliant" will be attached to the carton box.</b>	