



## Datasheet

# RS PRO Type 2 21mm dia x 6mm H

Stock number: 172-0854

EN



DIMENSIONS	TOLERANCE
<4mm	±0.15
4mm~15mm	±0.20
15mm~30mm	±0.30
30mm~50mm	±0.50
50mm~100mm	±1.00

REVISIONS			
REV	DESCRIPTION	DATE	BY
01	NEW DRAWING	2016-7-16	Jack Xu

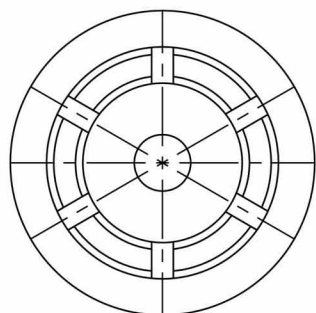
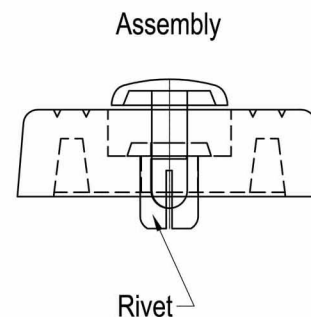
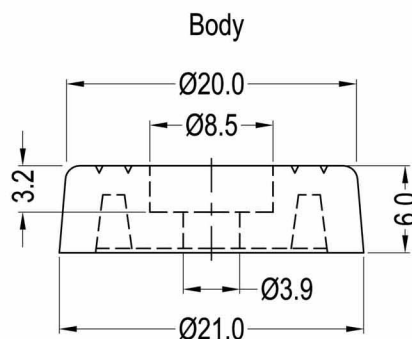

**NOTES:**

1.MATERIAL: TPV UL94 HB(Body)  
PA6 UL94 V2(Rivet)

2.Hole:Ø4.1~4.2mm  
Panel Thickness:0.8~1.8mm  
Mounting Rivet R4060B

Unit:mm

	SCALE	2:1	PART NAME	Soft Fast Foot
	COLOR	BLACK	PART NO.	172-0854
	DRAWN	ALEX	MATERIAL	SEE NOTES
	CHECK	JACK	DRAWING NO.	KS180712-8
	APPROVED	FRED	DRAWING DATE	2016-7-16