



Main

Range of product	Modicon TM3
Product or component type	Discrete output module
Range compatibility	Modicon M241 Modicon M251 Modicon M221 Modicon M262
Discrete output type	Transistor
Discrete output number	32
Discrete output logic	Positive logic (source)
Discrete output voltage	24 V DC for transistor output
Discrete output current	100 mA for transistor output

Complementary

Discrete I/O number	32
Current consumption	5 mA at 5 V DC via bus connector (at state off) 0 mA at 24 V DC via bus connector (at state off) 25 mA at 5 V DC via bus connector (at state on) 40 mA at 24 V DC via bus connector (at state on)
Response time	450 µs (turn-on) 450 µs (turn-off)
Maximum leakage current	0.1 mA for transistor output
Maximum voltage drop	<0.4 V
Maximum tungsten load	<1.2 W for transistor output
Local signalling	1 LED per channel (green) for output status
Electrical connection	HE-10 connector for outputs
Maximum cable distance between devices	Unshielded cable: <5 m for transistor output
Insulation	Between output and internal logic at 500 V AC Non-insulated between outputs
Marking	CE
Mounting support	Top hat type TH35-15 rail conforming to IEC 60715 Top hat type TH35-7.5 rail conforming to IEC 60715 Plate or panel with fixing kit
Height	90 mm
Depth	81.3 mm
Width	33.5 mm
Product weight	0.112 kg

Environment

Standards	EN/IEC 61131-2
Product certifications	CULus CE UKCA RCM EAC CULus HazLoc
Resistance to electrostatic discharge	8 kV in air conforming to EN/IEC 61000-4-2 4 kV on contact conforming to EN/IEC 61000-4-2
Resistance to electromagnetic fields	10 V/M 80 MHz...1 GHz conforming to EN/IEC 61000-4-3 3 V/M 1.4 GHz...2 GHz conforming to EN/IEC 61000-4-3 1 V/m 2 GHz...3 GHz conforming to EN/IEC 61000-4-3
Resistance to magnetic fields	30 A/m 50/60 Hz conforming to EN/IEC 61000-4-8

Resistance to fast transients	1 kV for I/O conforming to EN/IEC 61000-4-4
Surge withstand	1 kV I/O common mode conforming to EN/IEC 61000-4-5 DC
Resistance to conducted disturbances	10 V 0.15...80 MHz conforming to EN/IEC 61000-4-6 3 V spot frequency (2, 3, 4, 6.2, 8.2, 12.6, 16.5, 18.8, 22, 25 MHz) conforming to Marine specification (LR, ABS, DNV, GL)
Electromagnetic emission	Radiated emissions - test level: 40 dB μ V/m QP class A (10 m) at 30...230 MHz conforming to EN/IEC 55011 Radiated emissions - test level: 47 dB μ V/m QP class A (10 m) at 230...1000 MHz conforming to EN/IEC 55011
Ambient air temperature for operation	-10...35 °C vertical installation -10...55 °C horizontal installation
Ambient air temperature for storage	-25...70 °C
Relative humidity	10...95 %, without condensation (in operation) 10...95 %, without condensation (in storage)
IP degree of protection	IP20 with protective cover in place
Pollution degree	2
Operating altitude	0...2000 m
Storage altitude	0...3000 m
Vibration resistance	3.5 mm at 5...8.4 Hz on DIN rail 3 gn at 8.4...150 Hz on DIN rail 3.5 mm at 5...8.4 Hz on panel 3 gn at 8.4...150 Hz on panel
Shock resistance	15 gn for 11 ms

Packing Units

Unit Type of Package 1	PCE
Number of Units in Package 1	1
Package 1 Height	7.525 cm
Package 1 Width	10.661 cm
Package 1 Length	12.89 cm
Package 1 Weight	220.0 g
Unit Type of Package 2	CAR
Number of Units in Package 2	42
Package 2 Height	29.6 cm
Package 2 Width	39.6 cm
Package 2 Length	56.4 cm
Package 2 Weight	10.32 kg
Unit Type of Package 3	P12
Number of Units in Package 3	504
Package 3 Height	75 cm
Package 3 Width	120 cm
Package 3 Length	80 cm
Package 3 Weight	138.4 kg

Offer Sustainability

Sustainable offer status	Green Premium product
REACH Regulation	REACH Declaration
EU RoHS Directive	Pro-active compliance (Product out of EU RoHS legal scope) EU RoHS Declaration
Toxic heavy metal free	Yes
Mercury free	Yes
China RoHS Regulation	China RoHS Declaration
RoHS exemption information	Yes
Environmental Disclosure	Product Environmental Profile
Circularity Profile	End Of Life Information
WEEE	The product must be disposed on European Union markets following specific waste collection and never end up in rubbish bins

PVC free	Yes
California proposition 65	WARNING: This product can expose you to chemicals including: Lead and lead compounds, which is known to the State of California to cause cancer and birth defects or other reproductive harm. For more information go to www.P65Warnings.ca.gov

Dimensions

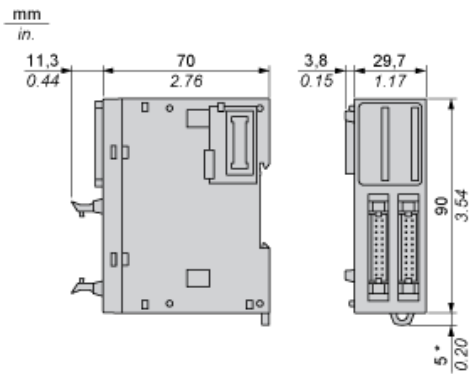

(*) 8.5 mm/0.33 in. when the clamp is pulled out.

Spacing Requirements

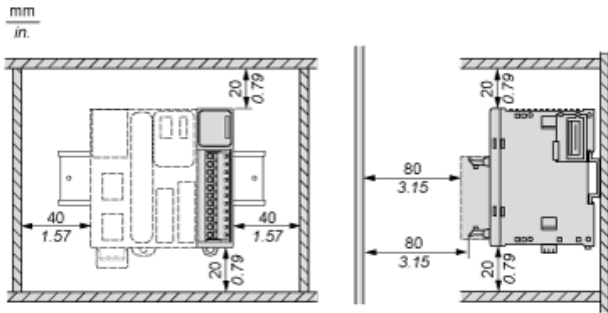

Mounting on a Rail

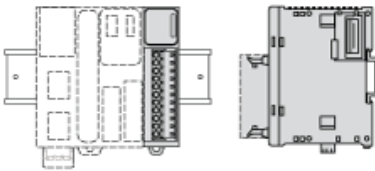

Incorrect Mounting

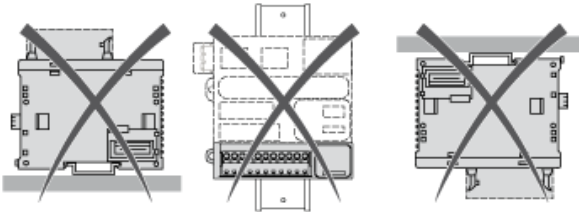

Mounting on a Panel Surface

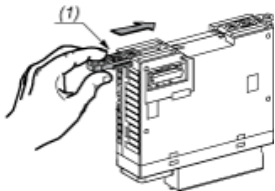

- (1) Install a mounting strip

Mounting Hole Layout

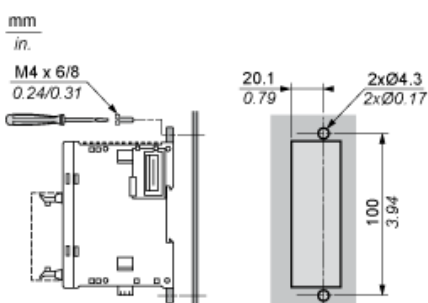

Digital Transistor Output Module (32-channel, Source)

Wiring Diagram

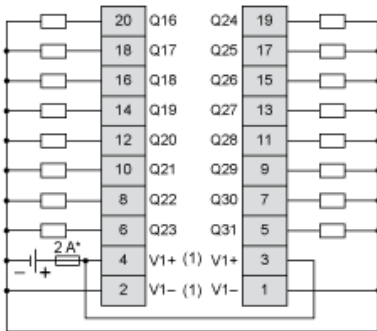
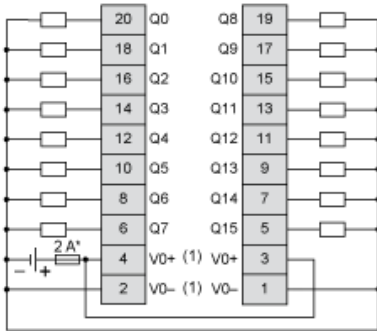

- (*) Type T fuse
- (1) The V0+ terminals are connected internally.
The V0- terminals are connected internally.
The V1+ terminals are connected internally.
The V1- terminals are connected internally.
The V0+ and V1+ terminals are not connected internally.
The V0- and V1- terminals are not connected internally.