

Datasheet

RS PRO Piezo Audio Indicator

EN



A. SCOPE

This specification applies piezo audio indicator, 1812656

B. SPECIFICATION

No.	Item	Unit	Specification	Condition
1	Resonant frequency	KHz	4.0 ± 0.5	
2	Operating Volt. range	VDC	3 ~ 15	
3	Current consumption	mA	MAX 12	at 12VDC
4	Sound pressure level	dB	MIN 90	at 10cm/12VDC
5	Rated Voltage	VDC	12	
6	Tone		Continuous	
7	Operating temp.	°C	-40 ~ +85	
8	Storage temp.	°C	-40 ~ +90	
9	Dimension	mm	φ 17.0 x H6.0	See appearance drawing
10	Weight (MAX)	gram	2.3	
11	Material		PPS (BLACK)	
12	Terminal		SMD type (Plating Sn)	See appearance drawing
13	Environmental Protection Regulation		RoHS2.0	Piezo electronic device is exempted from RoHS2.0. Lead contain restriction.
14	Storage life	month	6	6 months preservation at room temp.(25±3°C), Humidity40%
13	MSL		5a	≤30°C/60%RH 24H Floor life

C. APPEARANCE DRAWING

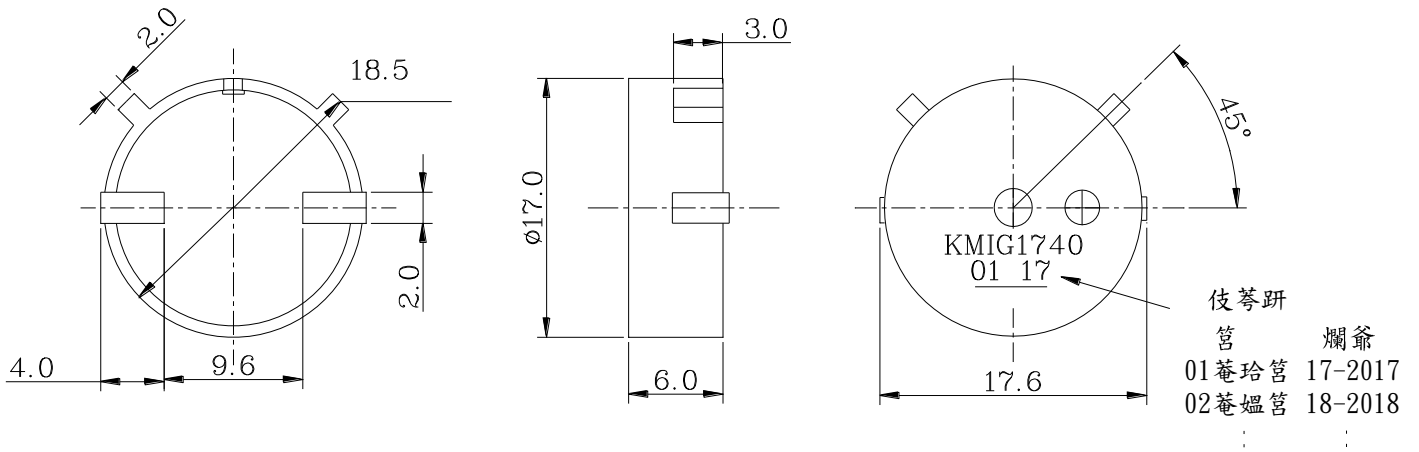

Tol : ± 0.5 Unit : mm

D. PRODUCT PICTURE 產品照片 (RANDOM DELIVERY 隨機發貨)

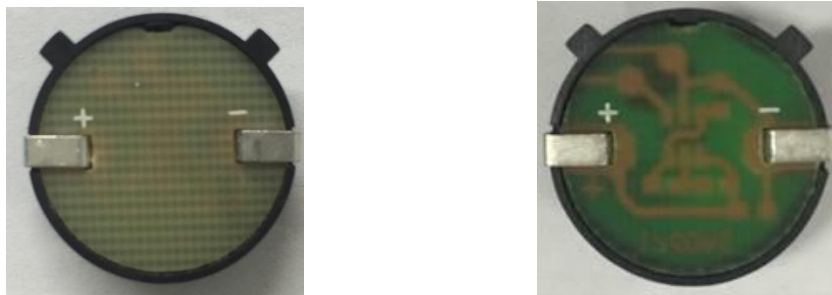

E. MEASURING METHOD

S.P.L. Measuring Circuit

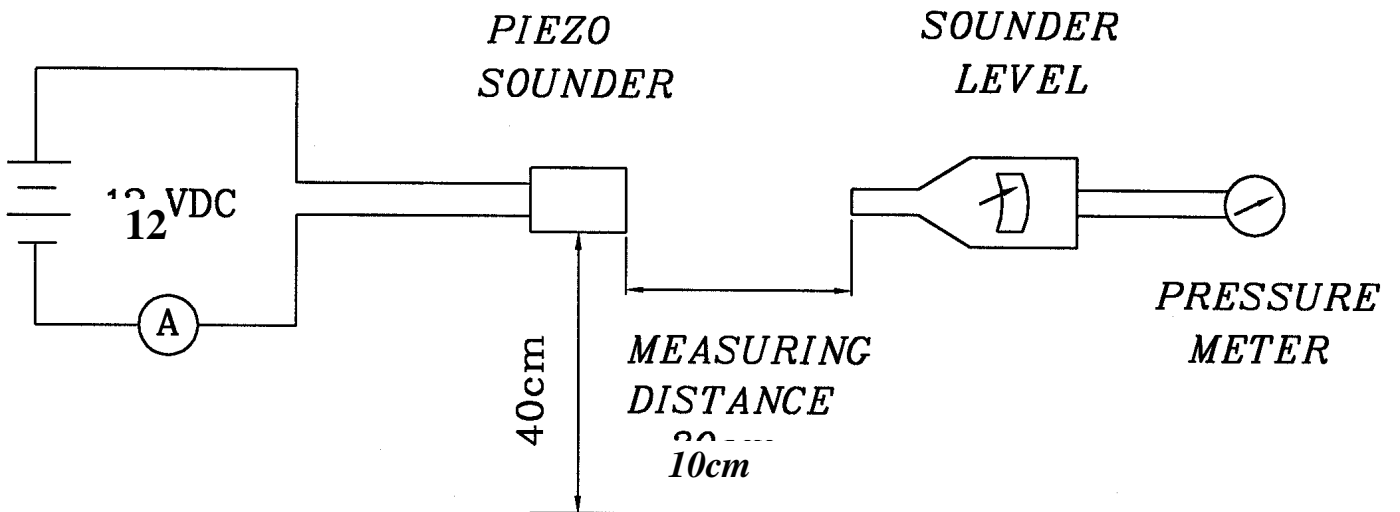

Mic : RION S.P.L meter UC30 or equivalent

Mic : RION /UC30

F. VOLTAGE:SOUND PRESSURE LEVEL / VOLTAGE: CURRENT CONSUMPTION CHARACTERISTICS For Reference Only

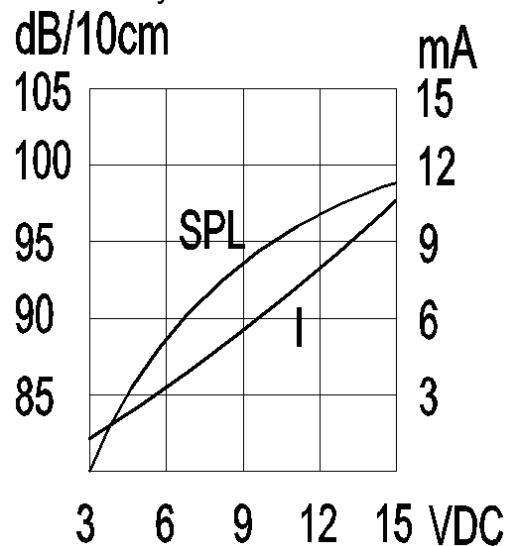

G. MECHANICAL CHARACTERISTICS

No.	Item	Test Condition	Evaluation standard
1	Solderability	Lead terminals are immersed in rosin for 5 seconds and then immersed in solder bath of $+270\pm 5^{\circ}\text{C}$ for 3 ± 1 seconds.	90% min. lead terminals shall be wet with solder. (Except the edge of terminal)
2	Soldering Heat Resistance	Lead terminal are immersed up to 1.5mm from sounder's body in solder bath of $+300\pm 5^{\circ}\text{C}$ for 3 ± 0.5 seconds or $+260\pm 5^{\circ}\text{C}$ for 10 ± 1 seconds.	No interference in operation .
3	Terminal Mechanical Strength	The force 10 seconds of 9.8N (1.0kg) is applied to each terminal in axial direction.	No damage and cutting off
4	Vibration	Buzzer shall be measured after being applied vibration of amplitude of 1.5mm with 10 to 55hz band of vibration frequency to each of 3 per-pendicular directions for 2 hours.	The value of oscillation frequency/ current consumption should be in 10% compared with initial ones .The SPL should be in $\pm 10\text{dB}$ compared with initial one.
5	Drop test	The part only shall be dropped from a height of 70cm onto a 10mm thick wooden board 3 times in 3 axes (X.Y.Z). (a total of 9 times)..	

H. ENVIRONMENT TEST

No.	Item	Test Condition	Evaluation standard
1	High temp. test	After being placed in a chamber at +90°C for 120 hours	Being placed for 4 hours at +25°C, buzzer shall be measured. The value of oscillation frequency/ current consumption should be in ±10% compared with initial ones. The SPL should be in ±10dB compared with initial one.
2	Low temp. test	After being placed in a chamber with -40°C for 120 hours	
3	Humidity test	After being placed in a chamber at +40°C ± 2°C and 90~95% relative humidity for 120 hours	
4	Temp. cycle test	<p>The part shall be subjected to 5 cycles. One cycle shall be consist of :</p> <p>The diagram shows a temperature cycle profile over a 3-hour period. It starts at -40 ± 2°C, ramps up to +40 ± 5°C in 0.5 hours, dwells at +40 ± 5°C for 0.25 hours, ramps up to +90 ± 2°C in 0.5 hours, dwells at +90 ± 2°C for 0.5 hours, ramps down to +40 ± 5°C in 0.5 hours, dwells at +40 ± 5°C for 0.25 hours, and finally ramps down to -40 ± 2°C in 0.25 hours. The total duration of one cycle is 3 hours.</p>	

I. RELIABILITY TEST

No.	Item	Test condition	Evaluation
1	Operating life test	<p>1. Continuous life test 48 hours continuous operation at +70°C with rated voltage applied.</p> <p>2. Intermittent life test A duty cycle of 1 minute on, 1 minutes off, a minimum of 5000 times at room temp. (+25 ± 2°C) and rated voltage applied.</p>	Being placed for 4 hours at +25°C, buzzer shall be measured. The value of oscillation frequency/ current consumption should be in ±10% compared with initial ones. The SPL should be in ±10dB compared with initial one.

TEST CONDITION.

Standard Test Condition : a) Temperature : +5 ~ +35°C b) Humidity : 45-85%

Judgement Test Condition : a) Temperature : +25 ± 2°C b) Humidity : 60-70%

c) Pressure : 860-1060mbar

c) Pressure : 860-1060mbar

J. Recommended Temperature Profile for Reflow Oven

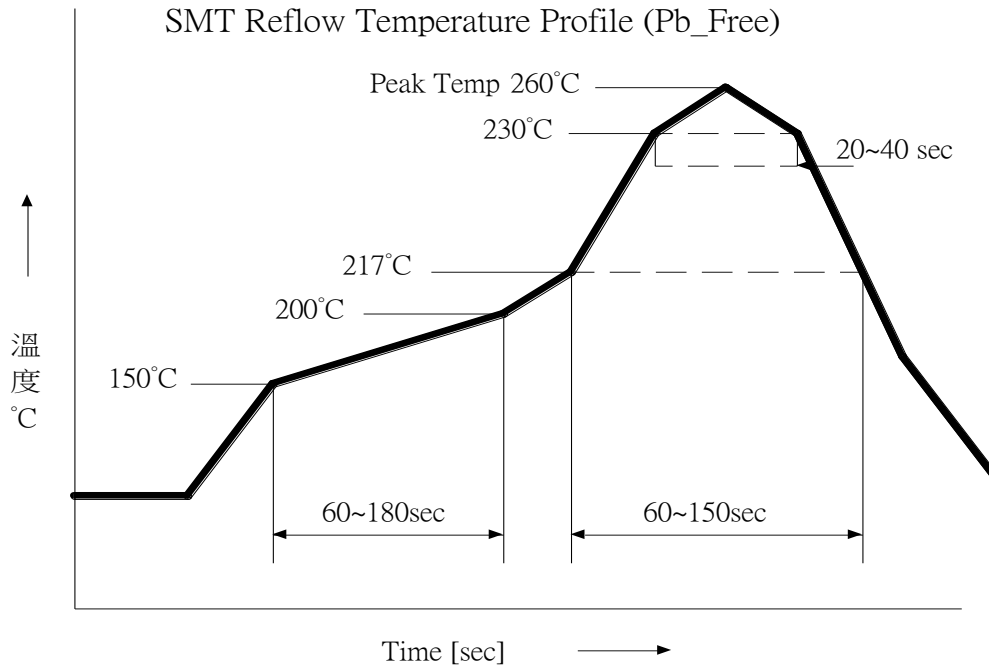

*Reflow can't over 1time.

K. Recommended land pattern

