

För icke direkt toleranssatta mått gäller toleransklass
General tolerances if not otherwise stated

NOM DIM MM		TOL CLASS		
From	To	A	B	C
(1)	6	±0.05	±0.1	±0.2
(6)	30	±0.1	±0.2	±0.5
(30)	100	±0.15	±0.3	±0.8
(100)	300	±0.2	±0.5	±1.2
(300)	1000	±0.3	±0.8	±2

Hål / Holes H13

Skarpa kanter brutna där ej annat anges.
No sharp edges unless otherwise specified.

Övriga generella toleranser enligt ritning 4100-4644.
Additional general tolerances in accordance with drawing 4100-4644.

LASERMÄRKNING/LASER MARKING:

TEXTFONT: GEN-ISO

Datumkod / Date code "YYYYYY"

Serienummer / Serial number "XXXXXXX"

Rev	Change order	Change: A = Added W = Was D = Deleted C = Changed	Date	Sign
-----	--------------	---	------	------

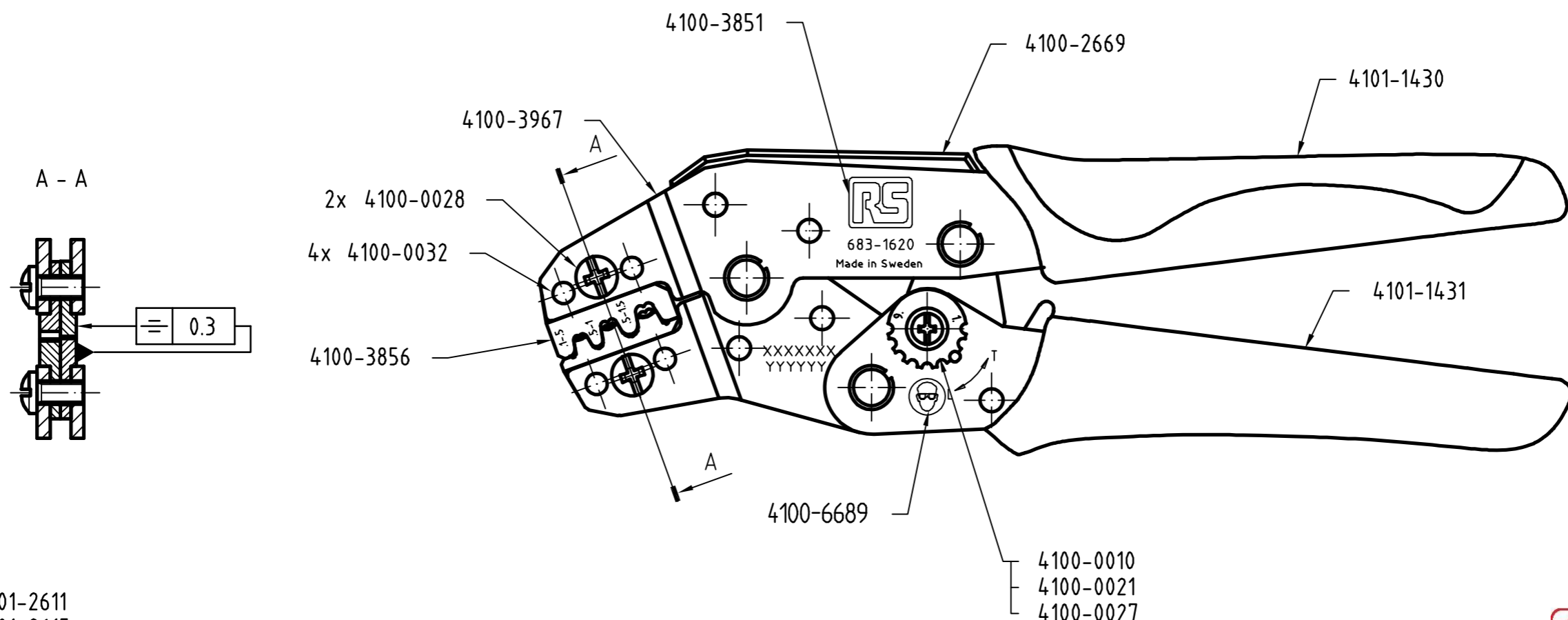
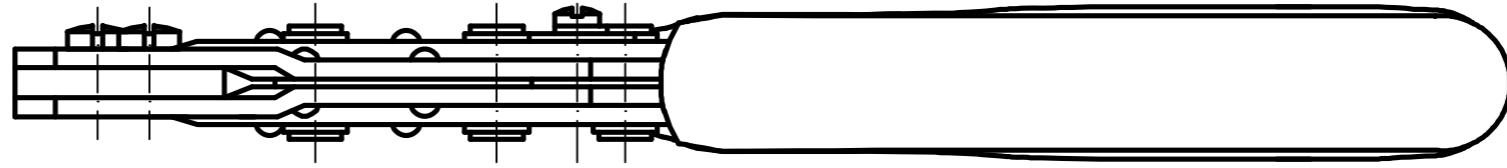

4101-2611
4101-2615
4100-3776
4101-6494 H - placering position B

FÖRSPÄNNING/PRELOAD: 150 ± 30 N



Packas enligt förpackningsritning 4101-2723
Packed according to drawing 4101-2723

Material		Behandling/Treatment			Status Frisläppt	
Konstr/Design SE	Ritad/Drawn SE	Datum/Date 2009-05-18	Skala/Scale 1:1	Kontr/Checked MAHA	Godk/Approved NE	Anne/Blank
Benämning/Denomination KRIMPVERKTYG 683-1620 CRIMPING TOOL				Vikt/Weight,gram 0.436 g	Art grp 012	
				Ritn nr/Drawing no 43003721	REV 000	