

## Installation and Service Instructions for Self Adjust Brakes 81,000 Series

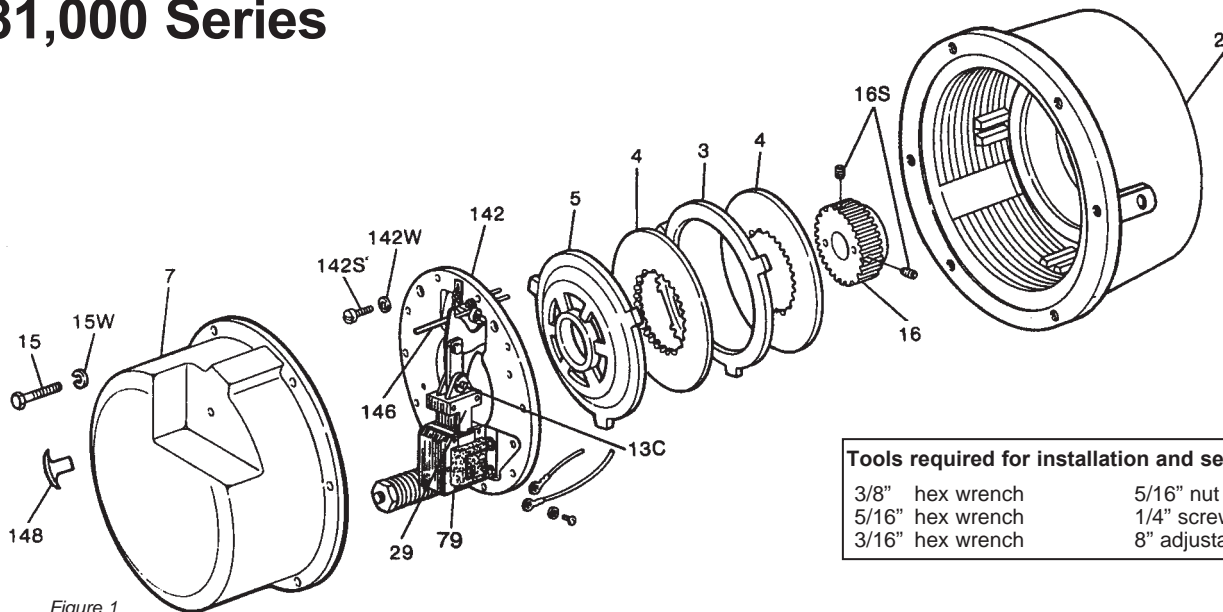
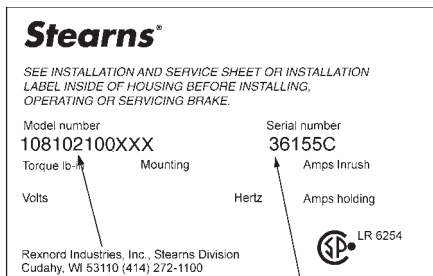

Figure 1

### Tools required for installation and servicing:

|                  |                      |
|------------------|----------------------|
| 3/8" hex wrench  | 5/16" nut driver     |
| 5/16" hex wrench | 1/4" screwdriver     |
| 3/16" hex wrench | 8" adjustable wrench |



Note:

**MODEL NUMBER**  
Refer to actual nameplate on brake for additional information

**SERIAL NUMBER**

### Important

Please read these instructions carefully before installing, operating, or servicing your Stearns Brake. Failure to comply with these instructions could cause injury to personnel and/or damage to property if the brake is installed incorrectly. For definition of limited warranty/liability, contact Rexnord Industries, LLC, Stearns Div., 5150 S. International Dr., Cudahy, WI 53110, (414) 272-1100.

### Caution

- Installation and servicing must be made in compliance with all local safety codes including Occupational Safety and Health Act (OSHA). All wiring and electrical connections must comply with the National Electric Code (NEC) and local electric codes in effect.
- Use of this brake in atmospheres containing explosive gases and dusts must be in accordance with NEC article 501. This brake is not suitable for use in certain atmospheres containing explosive gases and dusts. **HazLoc** inspection authorities are responsible for verifying and authorizing the use of suitably designed and installed **HazLoc** equipment. When questions arise consult local **Authority Having Jurisdiction (AHJ)**.

- To prevent an electrical hazard, disconnect power source before working on the brake. If power disconnect point is out of sight, lock disconnect in the *off* position and tag to prevent accidental application of power.
- Make certain power source conforms to the requirements specified on the brake nameplate.
- Be careful when touching the exterior of an operating brake. Allow sufficient time for brake to cool before disassembly. Surfaces may be hot enough to be painful or cause injury.
- Do not operate brake with housing removed. All moving parts should be guarded.
- Installation and servicing should be performed only by qualified personnel familiar with the construction and operation of the brake.
- For proper performance and operation, only genuine Stearns parts should be used for repairs and replacements.
- After usage, the brake interior will contain burnt and degraded friction material dust into the air or inhaling it, as this may be dangerous to your health.
- DO NOT BLOW OFF DUST** using an air hose. It is important to avoid dispersing dust into the air or inhaling it, as this may be dangerous to your health.
  - Wear a filtered mask or a respirator while removing dust from the inside of a brake.
  - Use a vacuum cleaner or a soft brush to remove dust from the brake. When brushing, avoid causing the dust to become airborne. Collect the dust in a container, such as a bag, which can be sealed off.
- Caution!** While the brake is equipped with a manual release to allow manual shaft rotation, the motor should not be run with the manual

release engaged, to avoid overheating the friction disc(s).

### General Description

This series brake is spring-set, electrically released. They contain two or three rotating friction discs (4) driven by a hub (16) mounted on the motor or other shaft.

**Note:** Fan-guard mounted brakes requiring IP54 & IP55 protection may require additional sealing measures beyond seals provided with this brake. Pressurized sprays aimed at the fan and brake hub surfaces can result in fluid migration along the motor shaft and keyway, and into the brake. The use of an appropriate sealant such as *RTV* or a *forsheda* seal is advised.

### Operating Principle

This series contains two or three friction discs (4) assembled alternately between the endplate (2) friction surface, stationary disc(s) (3) and pressure plate (5). The stationary components are restrained from rotating by being keyed into the endplate. With the brake released, all disc pack components are free to slide axially and the friction disc(s) to rotate.

Brake release occurs when the solenoid coil is electrically energized, causing the solenoid plunger to travel a specified distance and through a lever system, overcoming the pressure spring force. This action released the clamping force on the disc pack, thereby allowing the friction disc(s) and brake hub to rotate.

Brake sets and torque is produced when electric current to the solenoid coil is interrupted, thereby collapsing the solenoid magnetic field. The solenoid plunger returns to its original de-energized position allowing the lever arm to move forward by virtue of the compressed torque springs. This action compressed the disc pack components which applies a retarding torque to the brake hub and ultimately restores the brake to a spring-set condition.

- 1** Remove manual release knob.  
Remove housing screws.  
Remove housing.

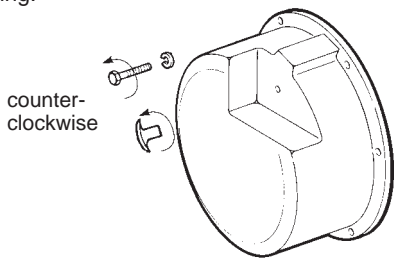

- 2** A. Push plunger down.  
B. Pull manual release to hold plunger.  
C. Remove support plate screws.

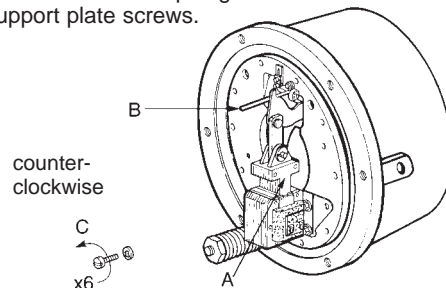

- 3** Lift off support plate.  
Remove disc pack.

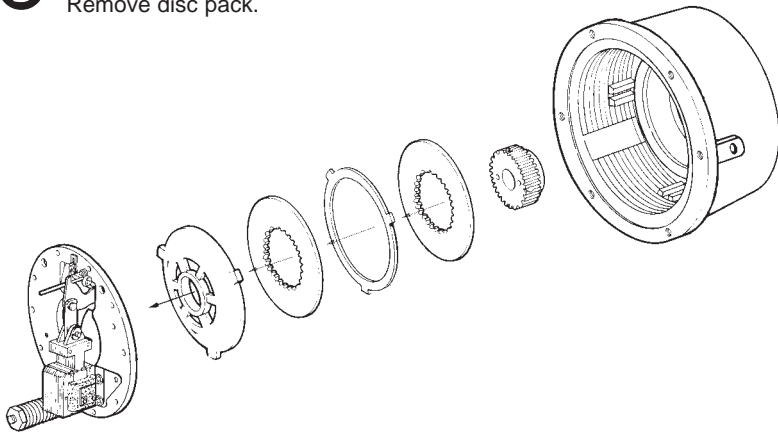

- 4** A. Position endplate on motor register.  
B. Insert four mounting bolts and tighten.  
(Torque per manufacturer specification)

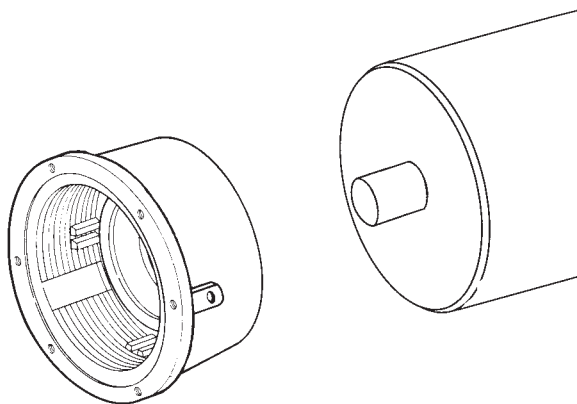

- 5** A. Position hub on shaft as shown.  
Tighten set screws to motor shaft.  
Torque to: 5/16" - 156 lb-in;  
3/8" - 288 lb-in;  
1/2" - 625 lb-in.  
B. Reassemble disc pack in reverse\*  
order of removal.

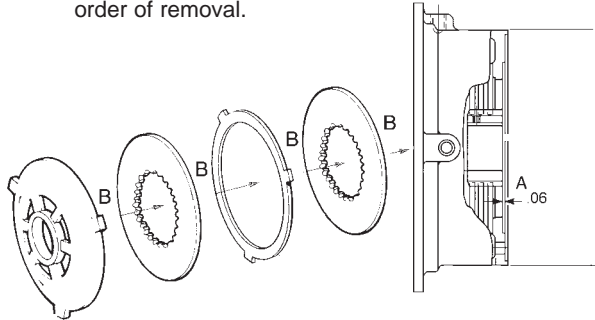

- 6** A. Route lead wires through conduit hole.  
B. Position support plate on endplate.  
C. Insert six mounting screws with lockwashers;  
tighten to 85-100 lb-in.

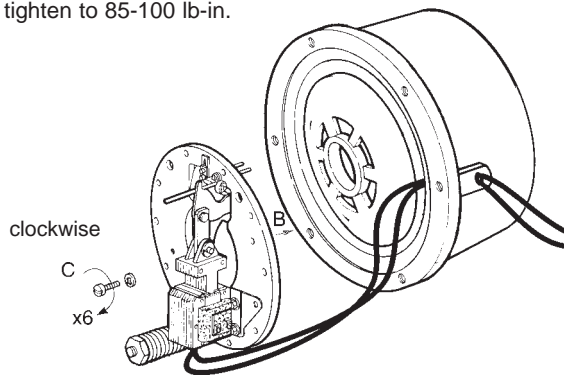

- 7** AC coils are 50/60 hz, single phase rated. Power supply to coil must not have current or frequency limiting output that is less than the coil requirement. Voltage supply to the coil must be within  $\pm 10\%$  of nameplate rating.\*

Caution: Keep wiring away from pinch points.

\* For DC voltages see sheet 8-078-950-00.

### Coil Wiring

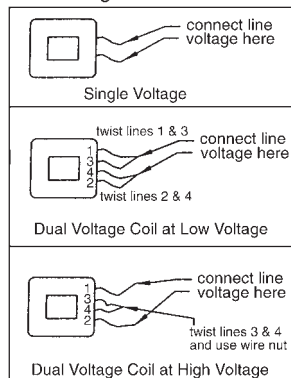

- 8** Replace housing.  
Tighten housing screws to 130 lb-in and release knob to 50 lb-in.

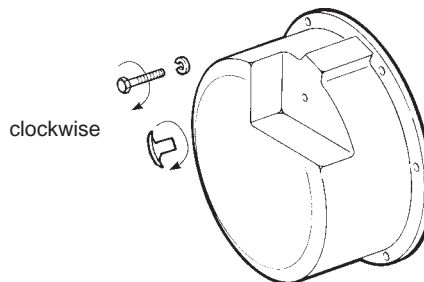

**General Maintenance**

**Warning!** Any mechanism or load held in position by the brake should be secured to prevent possible injury or damage to equipment before any disassembly of the brake is attempted or the manual release knob or lever is operated on the brake. Observe all cautions listed at the beginning of this manual.

**Note:** Do not lubricate any part of the brake as this may cause a malfunction and/or a loss of torque.

**Troubleshooting**

**A. If brake does not stop properly, coasts or overheats:**

1. Check that manual release knob is not in released mode.
2. Check for excessively worn, charred or broken friction discs.
3. Check that hub has not loosened and shifted on motor shaft.
4. Check that friction discs slide freely over hub. Clean hub and/or file burrs and nicks if required.
5. Check that stationary disc(s) and/or pressure plate can move freely in endplate and that they are not warped from overheating.
6. Check endplate slots for wear in the areas where stationary disc(s) and/or pressure plate make contact. Grooves in slots can prevent free disc movement and result in torque loss, stationary disc or friction disc breakage.
7. On vertically mounted brakes, check that springs are installed correctly and that stationary disc(s) can slide freely over vertical mounting pins. Check for wear on plunger guide bracket.
8. Confirm that the pressure spring nut (19) is properly tightened against the spacer (134) under the nut. Spring length should be measured from the cast surface of the

support plate to the bottom side of the spring nut. Spring lengths are based on the brake fully assembled, using a new disc pack. Spring length will increase as the disc pack wears.

| Torque (lb-ft) | Compressed Spring Length |
|----------------|--------------------------|
| 125            | 4-23/32"                 |
| 175            | 4-23/32"                 |
| 230            | 4-27/32"                 |

9. Check solenoid air gap (see page 4). Adjust if necessary.
10. Check that solenoid linkage can move freely. It requires approximately 18 lbs of pressure on the 125 lb-ft; 23 lbs on the 175, and 230 lb-ft to seat solenoid plunger correctly functioning brake.
11. Check voltage reading at coil terminals against coil voltage rating.
12. Check that brake coil is energized at the same time as, or prior to, motor and de-energized at the same time, or after, motor.
13. If stopping time exceeds 1 second, or if the application requires more than five stops per minute, check the thermal requirements to stop load against the thermal capacity of the brake.
14. Check for excessive voltage drop in motor line when motor is started. check wire gauge of supply line against motor starting current and solenoid inrush current. Measure voltage drop at solenoid coil terminals during maximum inrush current condition. To accomplish this, insert a block of wood, or other non-magnetic material, between solenoid plunger and frame. Block thickness should approximately equal solenoid air gap. Energize motor and brake simultaneously,

take reading and immediately shut down. This is to prevent motor, brake or solenoid burnup.

**B: If brake hums, solenoid pulls in slowly, or coil burns out:**

1. Check Items A-7, A-9, A-11 and A-14.
2. Check if shading coils are broken.
3. Check for worn plunger guides or if plunger rubs on solenoid frame laminations.
4. Check for worn solenoid plunger and frame.
5. Check if solenoid is dirty.
6. Check if solenoid mounting screws have loosened.
7. Check for worn or binding linkage. For normal pressure required to seat solenoid plunger to frame see A-10.

**C: If brake is noisy during stopping and/or friction discs shatter:**

1. Check for worn motor bearings allowing shaft runout.
2. On foot mounted brakes, recheck alignment.
3. Check hub position on shaft. The outboard face of hub should protrude 3/32" to 1/8" beyond face of outboard friction disc.
4. Check motor shaft endfloat. It should not exceed 0.020".
5. Check concentricity of endplate and C-face register. Alignment must be within .007" concentricity and face runout. Shaft runout should be within .002" TIR.

**Vertical Brake Assembly**

Refer to service sheet 8-078-931-05 and 8-078-931-15 for proper spring and spacer positions when brake is assembled for vertical orientation.

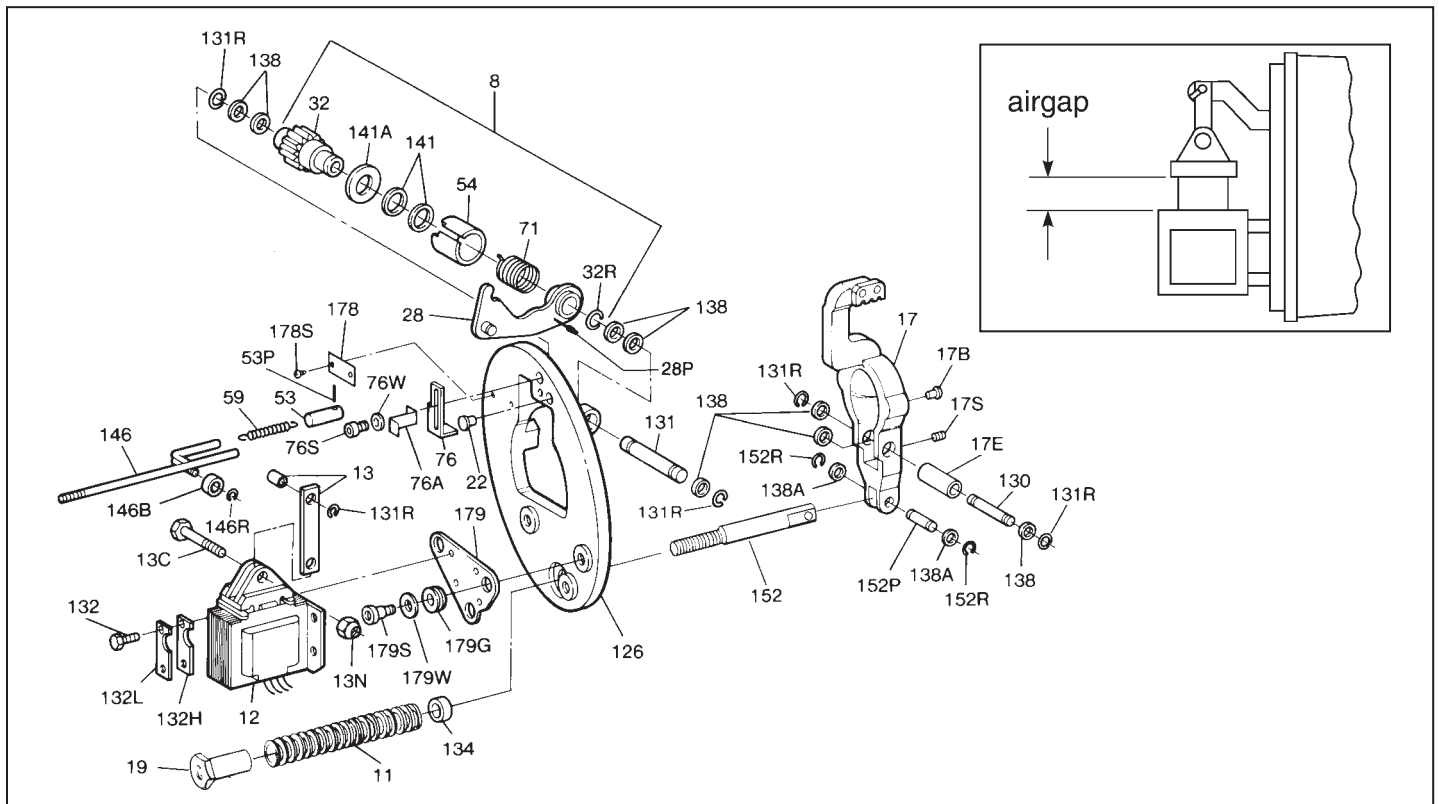

## AIR GAP ADJUSTMENT

- 1** Loosen two locking screws.  
Slide bracket outward to increase or inward to decrease air gap.  
Tighten screws to 45-55 lb-in.

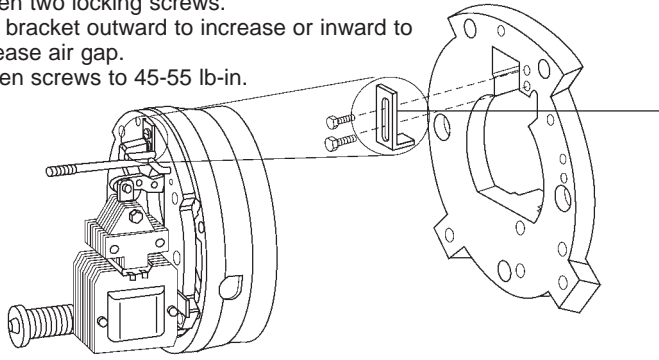

↑ increase air gap  
↓ decrease air gap

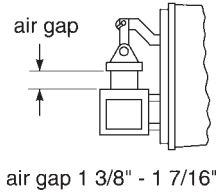

Wrap spring stop ① is positioned above the tang of the wrap spring ②

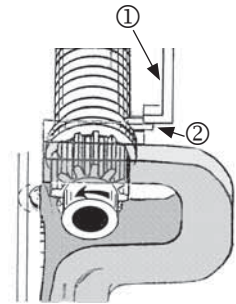

**Note:** Refer to page 2, Brake Mounting, for removal and replacement of housing.

## COIL REPLACEMENT

- 1** Disconnect coil lead wires from power source and pull them out of the brake.

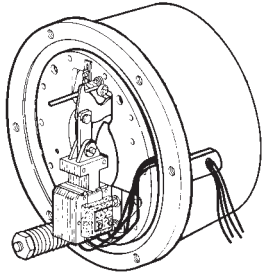

- 2** A. Remove solenoid mounting screws.  
B. Lift solenoid frame away from plunger.

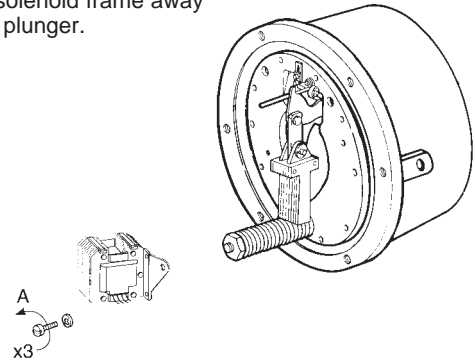

- 3** A. Remove guide screws.  
B. Lift guides out of coil.  
C. Push coil out of frame.

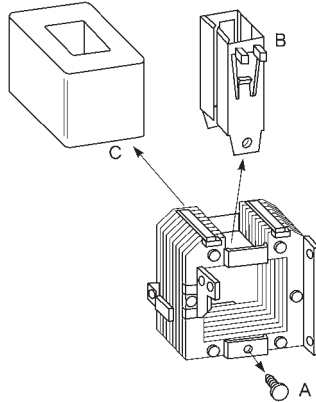

- 4** A. Insert new coil.  
B. Press plunger guides into place.  
C. Insert and tighten guide screws.

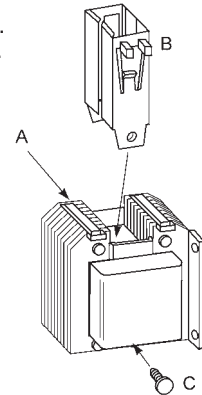

- 5** A. Slide coil assembly on to plunger.  
B. Insert mounting screws and tighten to 125 lb-in.

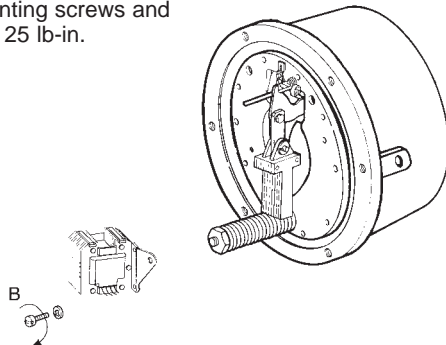

- 6** Reroute coil wires and reconnect to power supply.

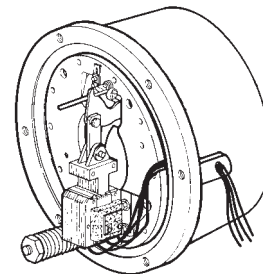

# FRICION DISC REPLACEMENT

[BACK TO PRODUCT PAGE](#)

- 1** Remove manual release knob.  
Remove housing screws.  
Remove housing.

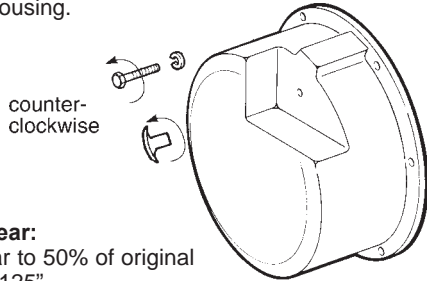

## Friction Disc Wear:

1. Discs can wear to 50% of original thickness, or .125".
2. Entire wear of disc pack cannot exceed the thickness of a new disc, or .250".

- 2** A. Push plunger down.  
B. Pull manual release to hold plunger.  
C. Remove support plate screws.

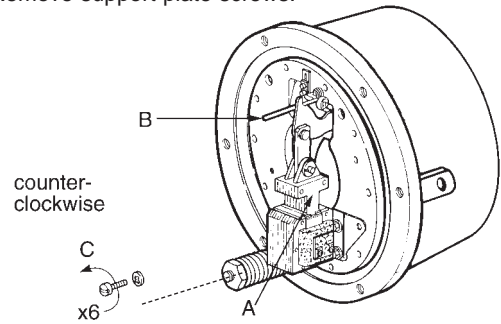

- 3** A. Remove support plate.  
B. Remove disc pack components.  
C. Discard old friction discs.

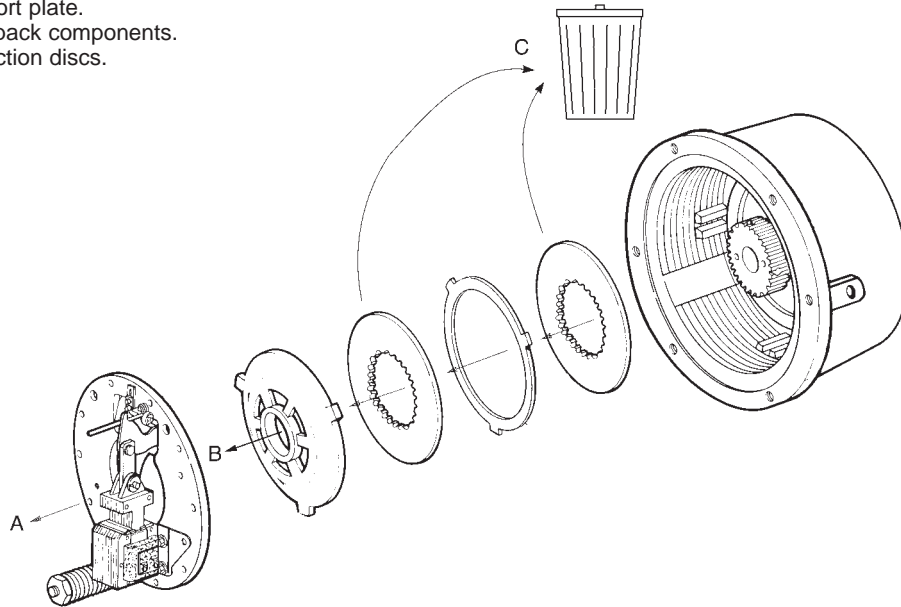

- 4** A. Install new friction discs and reassemble in reverse order of disassembly.\*  
B. Position support plate and tighten six screws to 75-78 lb-in.

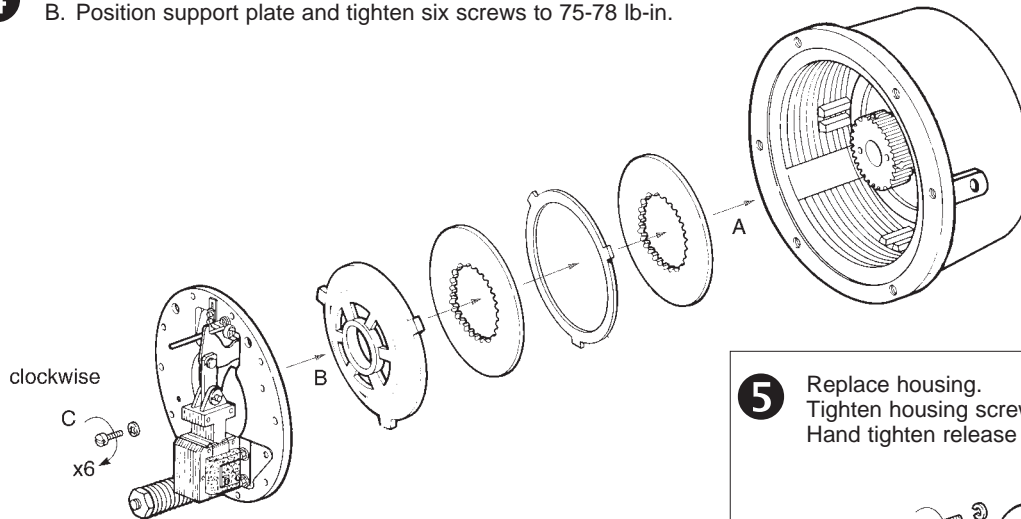

- 5** Replace housing.  
Tighten housing screws to 130 lb-in.  
Hand tighten release knob.

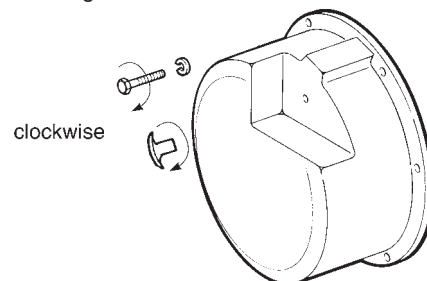



**Information required when ordering replacement parts:**

- Give part number of parts needed, brake model number and brake serial number. The brake model and serial number may identify special brakes not covered by this parts list.
- When ordering hubs, specify shaft diameter (hub bore) and keyway.
- Consult factory regarding support plate assembly for vertical and extra items.

- Enclosures are designated as follows:

O = Standard  
E - Dust-tight, waterproof (DTWP)

**General Information**

- Vertical details, see P/N 8-078-931-05 and 8-078-962-06.

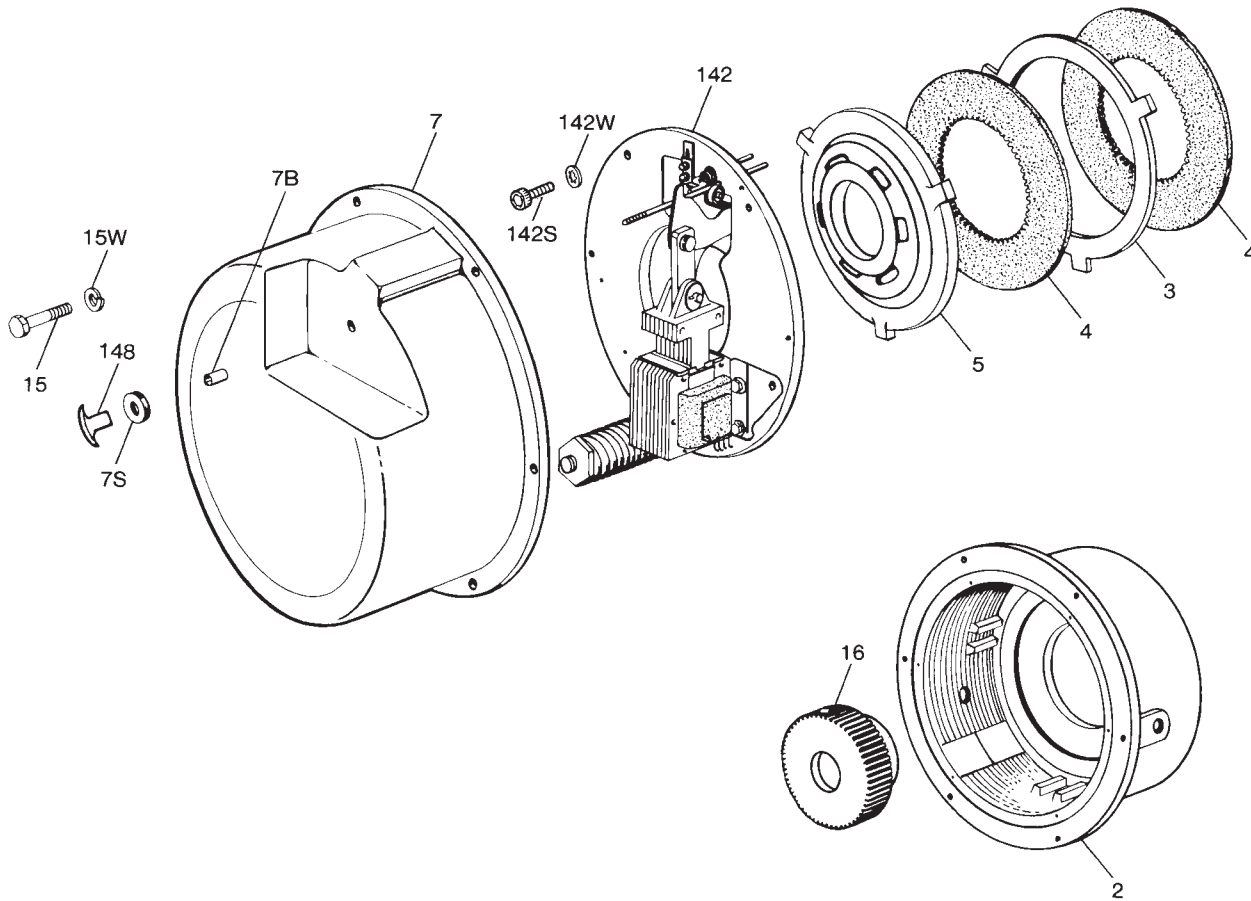

**Vertical Mounting  
below Motor**

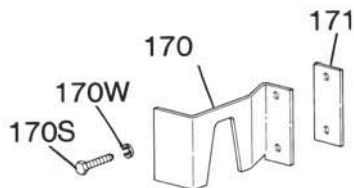

**Vertical Mounting  
above Motor**

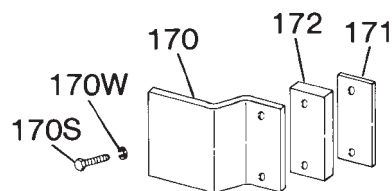

TABLE 1  
Components of Standard Horizontal AC or DC Units and Standard Modifications

|  |                       |  |  | Torque (lb-ft)      |              | 125          |              |              |              | 175          |              |              |              | 230          |              |              |   |              |  |              |  |              |  |              |  |              |  |              |  |
|--|-----------------------|--|--|---------------------|--------------|--------------|--------------|--------------|--------------|--------------|--------------|--------------|--------------|--------------|--------------|--------------|---|--------------|--|--------------|--|--------------|--|--------------|--|--------------|--|--------------|--|
|  |                       |  |  | Current             |              | AC           |              | DC           |              | AC           |              | DC           |              | AC           |              | DC           |   |              |  |              |  |              |  |              |  |              |  |              |  |
|  |                       |  |  | Enclosure           |              | O            | E            | O            | E            | O            | E            | O            | E            | O            | E            | O            | E |              |  |              |  |              |  |              |  |              |  |              |  |
|  |                       |  |  | Brake Model Number→ |              | 1-081-011-02 |              | 1-081-012-02 |              | 1-081-015-02 |              | 1-081-016-02 |              | 1-081-021-02 |              | 1-081-022-02 |   | 1-081-025-02 |  | 1-081-026-02 |  | 1-081-031-02 |  | 1-081-032-02 |  | 1-081-035-02 |  | 1-081-036-02 |  |
| Type of Modification   | Item No.              | Description  | Part Number↓   | 1-081-011-02        | 1-081-012-02 | 1-081-015-02 | 1-081-016-02 | 1-081-021-02 | 1-081-022-02 | 1-081-025-02 | 1-081-026-02 | 1-081-031-02 | 1-081-032-02 | 1-081-035-02 | 1-081-036-02 |              |   |              |  |              |  |              |  |              |  |              |  |              |  |
|  | 2                     | Endplate<br>Endplate<br>Endplate and oil seal assembly<br>Endplate and oil seal assembly   | 8-002-226-01<br>8-002-227-01<br>5-22-1011-00<br>5-22-1012-00                                 | 1                   |              | 1            |              | 1            |              | 1            |              | 1            |              | 1            |              | 1            |   |              |  |              |  |              |  |              |  |              |  |              |  |
|  | 2S                    | Seal (component of endplate and seal assembly)   | 9-02-0014-00   |                     | 1            |              | 1            |              | 1            |              | 1            |              | 1            |              | 1            |              |   |              |  |              |  |              |  |              |  |              |  |              |  |
|  | 3                     | Stationary disc  | 8-003-211-01   | 1                   | 1            | 1            | 1            | 1            | 1            | 1            | 1            | 2            | 2            | 2            | 2            |              |   |              |  |              |  |              |  |              |  |              |  |              |  |
|  | 4                     | Friction disc  | 8-004-104-00   | 2                   | 2            | 2            | 2            | 2            | 2            | 2            | 2            | 3            | 3            | 3            | 3            |              |   |              |  |              |  |              |  |              |  |              |  |              |  |
|  | 5                     | Pressure plate   | 8-005-109-01   | 1                   | 1            | 1            | 1            | 1            | 1            | 1            | 1            | 1            | 1            | 1            | 1            |              |   |              |  |              |  |              |  |              |  |              |  |              |  |
|  | 7                     | Housing, bearing and seal assembly   | 5-07-2012-00   | 1                   | 1            | 1            | 1            | 1            | 1            | 1            | 1            | 1            | 1            | 1            | 1            |              |   |              |  |              |  |              |  |              |  |              |  |              |  |
|  | 7B                    | Housing bearing (component of Item 7)  | 9-04-0050-00   | 1                   | 1            | 1            | 1            | 1            | 1            | 1            | 1            | 1            | 1            | 1            | 1            |              |   |              |  |              |  |              |  |              |  |              |  |              |  |
|  | 7D                    | Pipe plug (drain)  | 9-33-0325-00   | 1                   | 1            | 1            | 1            | 1            | 1            | 1            | 1            | 1            | 1            | 1            | 1            |              |   |              |  |              |  |              |  |              |  |              |  |              |  |
|  | 7S                    | Housing seal (component of Item 7)   | 9-02-0017-00   | 1                   | 1            | 1            | 1            | 1            | 1            | 1            | 1            | 1            | 1            | 1            | 1            |              |   |              |  |              |  |              |  |              |  |              |  |              |  |
|  | 15                    | Machine screw (housing)  | 9-17-3216-00   | 6                   | 6            | 6            | 6            | 6            | 6            | 6            | 6            | 6            | 6            | 6            | 6            |              |   |              |  |              |  |              |  |              |  |              |  |              |  |
|  | 15W                   | Lock washer (housing)  | 9-45-1332-00   | 6                   | 6            | 6            | 6            | 6            | 6            | 6            | 6            | 6            | 6            | 6            | 6            |              |   |              |  |              |  |              |  |              |  |              |  |              |  |
|  | 16                    | Hub and set screw assembly   | 5-16-1102-00   | 1                   | 1            | 1            | 1            | 1            | 1            | 1            | 1            | 1            | 1            | 1            | 1            |              |   |              |  |              |  |              |  |              |  |              |  |              |  |
|  | 69                    | Hub and set screw assembly<br>Gasket (housing to endplate)   | 5-16-1104-00<br>8-069-203-00   | 1                   | 1            | 1            | 1            | 1            | 1            | 1            | 1            | 1            | 1            | 1            | 1            |              |   |              |  |              |  |              |  |              |  |              |  |              |  |
|  | 140                   | Lead wire bushing (endplate) (internal connection only)<br>Lead wire bushing (endplate) (internal connection only)                                       | 8-140-002-08<br>8-140-002-10   | 1                   | 1            | 1            | 1            | 1            | 1            | 1            | 1            | 1            | 1            | 1            | 1            |              |   |              |  |              |  |              |  |              |  |              |  |              |  |
|  | 142                   | Support plate assembly<br>Support plate assembly<br>Support plate assembly<br>Support plate assembly<br>Support plate assembly<br>Support plate assembly | 5-42-2071-00<br>5-42-2072-00<br>5-42-2073-00<br>5-42-2074-00<br>5-42-2075-00<br>5-42-2076-00 | 1                   | 1            | 1            | 1            | 1            | 1            | 1            | 1            | 1            | 1            | 1            | 1            | 1            |   |              |  |              |  |              |  |              |  |              |  |              |  |
|  | 142S                  | Cap screw (support plate)  | 9-17-5016-00   | 6                   | 6            | 6            | 6            | 6            | 6            | 6            | 6            | 6            | 6            | 6            | 6            |              |   |              |  |              |  |              |  |              |  |              |  |              |  |
|  | 142W                  | Conical spring washer (support plate)  | 9-46-0006-00   | 6                   | 6            | 6            | 6            | 6            | 6            | 6            | 6            | 6            | 6            | 6            | 6            |              |   |              |  |              |  |              |  |              |  |              |  |              |  |
|  | 148                   | Release knob   | 8-148-804-00   | 1                   | 1            | 1            | 1            | 1            | 1            | 1            | 1            | 1            | 1            | 1            | 1            |              |   |              |  |              |  |              |  |              |  |              |  |              |  |
| Components for Standard Modifications (most items not shown) |                       |  |  |                     |              |              |              |              |              |              |              |              |              |              |              |              |   |              |  |              |  |              |  |              |  |              |  |              |  |
| Vertical Mounting Above Motor                                | 2                     | Endplate with pins<br>Endplate with pins<br>Endplate and seal assembly with pins<br>Endplate and seal assembly with pins                                 | 5-20-1001-00<br>5-20-1002-00<br>5-22-1015-00<br>5-22-1016-00                                 | 1                   |              | 1            |              | 1            |              | 1            |              | 1            |              | 1            |              | 1            |   |              |  |              |  |              |  |              |  |              |  |              |  |
|  | 3                     | Stationary disc  | 8-003-211-01   | 1                   | 1            | 1            | 1            | 1            | 1            | 1            | 1            | 2            | 2            | 2            | 2            |              |   |              |  |              |  |              |  |              |  |              |  |              |  |
|  | 5                     | Pressure plate   | 8-005-109-02   | 1                   | 1            | 1            | 1            | 1            | 1            | 1            | 1            | 1            | 1            | 1            | 1            |              |   |              |  |              |  |              |  |              |  |              |  |              |  |
|  | 7                     | Housing and side release assembly  | 5-07-1002-00   | 1                   | 1            | 1            | 1            | 1            | 1            | 1            | 1            | 1            | 1            | 1            | 1            |              |   |              |  |              |  |              |  |              |  |              |  |              |  |
|  | Not Shown             | Vertical mounting pin<br>Vertical mounting pin<br>Vertical mounting spring kit   | 8-061-204-00<br>8-061-205-00<br>5-96-0102-00   | 3                   | 3            | 3            | 3            | 3            | 3            | 3            | 3            | 3            | 3            | 3            | 3            |              |   |              |  |              |  |              |  |              |  |              |  |              |  |
|  | 170                   | Plunger guide bracket  | Kit<br>5-55-2002-00  | 1                   | 1            | 1            | 1            | 1            | 1            | 1            | 1            | 1            | 1            | 1            | 1            |              |   |              |  |              |  |              |  |              |  |              |  |              |  |
|  | 170S                  | Cap screw (bracket)  |  |                     |              |              |              |              |              |              |              |              |              |              |              |              |   |              |  |              |  |              |  |              |  |              |  |              |  |
|  | 170W                  | Lock washer (bracket)  |  |                     |              |              |              |              |              |              |              |              |              |              |              |              |   |              |  |              |  |              |  |              |  |              |  |              |  |
|  | 171                   | Shim (bracket)   |  |                     |              |              |              |              |              |              |              |              |              |              |              |              |   |              |  |              |  |              |  |              |  |              |  |              |  |
|  | 172                   | Spacer   |  |                     |              |              |              |              |              |              |              |              |              |              |              |              |   |              |  |              |  |              |  |              |  |              |  |              |  |
|  |                       | Release plate<br>Screw<br>Lock nut<br>Spring pin<br>Release rod  | 8-170-102-00<br>9-16-3012-00<br>9-40-3730-00<br>9-32-4055-00<br>8-146-201-01                 |                     | 1            | 1            | 1            | 1            | 1            | 1            | 1            | 1            | 1            | 1            | 1            |              |   |              |  |              |  |              |  |              |  |              |  |              |  |
|  |                       | Components of support plate vertical mounting  |  |                     | 2            | 2            | 2            | 2            | 2            | 2            | 2            | 2            | 2            | 2            | 2            |              |   |              |  |              |  |              |  |              |  |              |  |              |  |
|  |                       |  |  |                     | 2            | 2            | 2            | 2            | 2            | 2            | 2            | 2            | 2            | 2            | 2            |              |   |              |  |              |  |              |  |              |  |              |  |              |  |
|  |                       |  |  | **                  | **           | **           | **           | **           | **           | **           | **           | **           | **           | **           | **           |              |   |              |  |              |  |              |  |              |  |              |  |              |  |
| Foot Mounting  | 34                    | Foot mounting kit, comprised of:   | 5-55-2021-00   | 1                   | 1            | 1            | 1            | 1            | 1            | 1            | 1            | 1            | 1            | 1            | 1            |              |   |              |  |              |  |              |  |              |  |              |  |              |  |
|  | 34S                   | Foot mounting bracket  | 8-034-205-01   | 4                   | 4            | 4            | 4            | 4            | 4            | 4            | 4            | 4            | 4            | 4            | 4            |              |   |              |  |              |  |              |  |              |  |              |  |              |  |
|  | 39W                   | Cap screw<br>Lock washer   | 9-17-1624-00<br>9-45-1316-00   | 4                   | 4            | 4            | 4            | 4            | 4            | 4            | 4            | 4            | 4            | 4            |              |              |   |              |  |              |  |              |  |              |  |              |  |              |  |
| Vertical Mounting below Motor                                | 3                     | Stationary disc  | 8-003-211-01   | 1                   | 1            | 1            | 1            | 1            | 1            | 1            | 1            | 2            | 2            | 2            | 2            |              |   |              |  |              |  |              |  |              |  |              |  |              |  |
|  | 5                     | Pressure plate (less pins)   | 8-005-109-03   | 1                   | 1            | 1            | 1            | 1            | 1            | 1            | 1            | 1            | 1            | 1            |              |              |   |              |  |              |  |              |  |              |  |              |  |              |  |
|  | Not Shown             | Vertical mounting pin<br>Vertical mounting pin   | 8-061-206-00<br>8-061-207-00   | 3                   | 3            | 3            | 3            | 3            | 3            | 3            | 3            | 3            | 3            | 3            |              |              |   |              |  |              |  |              |  |              |  |              |  |              |  |
|  | Not Shown             | Vertical spring kit  | 5-96-0102-00   | 1                   | 1            | 1            | 1            | 1            | 1            | 1            | 1            | 1            | 1            | 1            |              |              |   |              |  |              |  |              |  |              |  |              |  |              |  |
|  | 170                   | Plunger guide bracket  | 8-170-205-00   | 2                   | 2            | 2            | 2            | 2            | 2            | 2            | 2            | 2            | 2            | 2            |              |              |   |              |  |              |  |              |  |              |  |              |  |              |  |
|  | 170S                  | Cap screw (bracket)  | 8-350-002-00   | 2                   | 2            | 2            | 2            | 2            | 2            | 2            | 2            | 2            | 2            | 2            |              |              |   |              |  |              |  |              |  |              |  |              |  |              |  |
| 170W   | Lock washer (bracket) | 9-45-0330-00   | 2  | 2                   | 2            | 2            | 2            | 2            | 2            | 2            | 2            | 2            | 2            |              |              |              |   |              |  |              |  |              |  |              |  |              |  |              |  |
| 171  | Shim (bracket)        | 8-454-016-00   | **   | **                  | **           | **           | **           | **           | **           | **           | **           | **           | **           | **           |              |              |   |              |  |              |  |              |  |              |  |              |  |              |  |
| Shaft Through Housing  | 7                     | Housing, bearing and seal assembly   | 5-07-2014-00   | 1                   | 1            | 1            | 1            | 1            | 1            | 1            | 1            | 1            | 1            | 1            |              |              |   |              |  |              |  |              |  |              |  |              |  |              |  |
|  | 24                    | Shaft bushing (specify bore)   | 8-024-202-01   | 1                   | 1            | 1            | 1            | 1            | 1            | 1            | 1            | 1            | 1            | 1            |              |              |   |              |  |              |  |              |  |              |  |              |  |              |  |
|  | 24L                   | Set screw (shaft bushing)  | 9-20-3004-00   | 2                   | 2            | 2            | 2            | 2            | 2            | 2            | 2            | 2            | 2            |              |              |              |   |              |  |              |  |              |  |              |  |              |  |              |  |
|  | 24S                   | Shaft seal (component of item 7)   | 9-02-0010-00   | 1                   | 1            | 1            | 1            | 1            | 1            | 1            | 1            | 1            | 1            |              |              |              |   |              |  |              |  |              |  |              |  |              |  |              |  |
| Space Heater   | Not Shown             | Heater (115 volt circuit) Kit  | 5-27-2006-00   | 1                   | 1            | 1            | 1            | 1            | 1            | 1            | 1            | 1            | 1            | 1            |              |              |   |              |  |              |  |              |  |              |  |              |  |              |  |
|  | Not Shown             | Heater (230 volt circuit) Kit  | 5-27-2007-00   | 1                   | 1            | 1            | 1            | 1            | 1            | 1            | 1            | 1            | 1            |              |              |              |   |              |  |              |  |              |  |              |  |              |  |              |  |

**Table 2** (see note)  
Components of  
Support Plate Assemblies

| Item No. | Description   | Part Number                  | Brake Size Torque (lb-ft) |    | 125 |    | 175 |    | 230 |   |
|----------|---|------------------------------|---------------------------|----|-----|----|-----|----|-----|---|
|          |   |                              | AC                        | DC | AC  | DC | AC  | DC |     |   |
| 8        | Solenoid lever and pinion assembly (comprised of Items 28, 32, 32R, 54, 71, 141 and 141A) | 5-66-7321-00                 | 1                         | 1  | 1   | 1  | 1   | 1  | 1   | 1 |
| 11       | Pressure spring (green)<br>Pressure spring (yellow)                                       | 9-70-4601-00<br>9-70-6001-00 | 1                         | 1  |     |    |     |    |     |   |
| 13       | Solenoid link and bearing assembly  | 5-55-2006-00                 | 1                         | 1  | 1   | 1  | 1   | 1  | 1   | 1 |
| 13C      | Cap screw (solenoid link)   | 8-157-703-00                 | 1                         | 1  | 1   | 1  | 1   | 1  | 1   | 1 |
| 13N      | Nut (solenoid link)   | 9-40-3732-00                 | 1                         | 1  | 1   | 1  | 1   | 1  | 1   | 1 |
| 17       | Lever arm assembly  | 5-17-2001-00                 | 1                         | 1  | 1   | 1  | 1   | 1  | 1   | 1 |
| 17B      | Pressure button   | 9-25-1908-00                 | 2                         | 2  | 2   | 2  | 2   | 2  | 2   | 2 |
| 17E      | Eccentric sleeve (lever arm)  | 8-054-201-00                 | 1                         | 1  | 1   | 1  | 1   | 1  | 1   | 1 |
| 17S      | Set screw (lever arm)   | 9-20-3004-00                 | 2                         | 2  | 2   | 2  | 2   | 2  | 2   | 2 |
| 19       | Pressure spring nut   | 8-019-202-01                 | 1                         | 1  | 1   | 1  | 1   | 1  | 1   | 1 |
| 22       | Solenoid lever stop   | 8-022-603-00                 | 1                         | 1  | 1   | 1  | 1   | 1  | 1   | 1 |
| 53       | Manual release spring tube  | 8-053-201-00                 | 1                         | 1  | 1   | 1  | 1   | 1  | 1   | 1 |
| 53P      | Roll pin (spring tube)  | 9-32-4012-00                 | 1                         | 1  | 1   | 1  | 1   | 1  | 1   | 1 |
| 59       | Release spring  | 9-71-0004-00                 | 1                         | 1  | 1   | 1  | 1   | 1  | 1   | 1 |
| 76       | Wrap spring stop  | 8-076-203-00                 | 1                         | 1  | 1   | 1  | 1   | 1  | 1   | 1 |
| 76A      | Holding plate (wrap spring stop)  | 8-076-204-00                 | 1                         | 1  | 1   | 1  | 1   | 1  | 1   | 1 |
| 76S      | Cap screw (spring stop)   | 9-17-2812-00                 | 2                         | 2  | 2   | 2  | 2   | 2  | 2   | 2 |
| 76W      | Lock washer (spring stop)   | 9-45-1328-00                 | 2                         | 2  | 2   | 2  | 2   | 2  | 2   | 2 |
| 126      | Support plate and bearing assembly  | 5-26-2004-00                 | 1                         | 1  | 1   | 1  | 1   | 1  | 1   | 1 |
| 130      | Pivot pin (lever arm)   | 8-118-204-00                 | 1                         | 1  | 1   | 1  | 1   | 1  | 1   | 1 |
| 131      | Pivot pin (solenoid lever)  | 8-131-201-00                 | 1                         | 1  | 1   | 1  | 1   | 1  | 1   | 1 |
| 131R     | Retaining ring (pivot pin)  | 9-03-0020-00                 | 5                         | 5  | 5   | 5  | 5   | 5  | 5   | 5 |
| 132      | Cap screw (solenoid mounting)   | 8-350-008-00                 | 4                         | 4  | 4   | 4  | 4   | 4  | 4   | 4 |
| 132H     | Holding plate (solenoid mounting)   | 8-076-207-00                 | 2                         | 2  | 2   | 2  | 2   | 2  | 2   | 2 |
| 132L     | Lock plate (solenoid mounting)  | 8-076-206-00                 | 2                         | 2  | 2   | 2  | 2   | 2  | 2   | 2 |
| 134      | Pressure spring spacer  | 8-134-001-02                 | 1                         | 1  | 1   | 1  |     |    | 1   | 1 |
|          | Pressure spring spacer  | 8-134-001-03                 |                           |    |     |    |     |    |     |   |
| 138      | Bearing (washer type)   | 8-138-201-00                 | 8                         | 8  | 8   | 8  | 8   | 8  | 8   | 8 |
| 138A     | Bearing (washer type)   | 8-138-701-00                 | 2                         | 2  | 2   | 2  | 2   | 2  | 2   | 2 |
| 146      | Release rod   | 8-146-201-00                 | 1                         | 1  | 1   | 1  | 1   | 1  | 1   | 1 |
| 146B     | Ball bearing (release rod)  | 9-01-6801-00                 | 1                         | 1  | 1   | 1  | 1   | 1  | 1   | 1 |
| 146R     | Retaining ring (release rod)  | 9-03-0007-00                 | 1                         | 1  | 1   | 1  | 1   | 1  | 1   | 1 |
| 152      | Pressure spring stud  | 8-152-201-00                 | 1                         | 1  | 1   | 1  | 1   | 1  | 1   | 1 |
| 152P     | Pivot pin (spring stud)   | 8-118-202-00                 | 1                         | 1  | 1   | 1  | 1   | 1  | 1   | 1 |
| 152R     | Retaining ring (spring stud)  | 9-03-0019-00                 | 2                         | 2  | 2   | 2  | 2   | 2  | 2   | 2 |
| 159      | Brake release interlock kit (standard manual release)                                     | 5-55-2005-00                 | 1                         | 1  | 1   | 1  | 1   | 1  | 1   | 1 |
|          | Brake release interlock kit (side manual release)   | 5-55-2004-00                 | 1                         | 1  | 1   | 1  | 1   | 1  | 1   | 1 |
| 178      | Instruction plate   | 8-078-055-00                 | 1                         | 1  | 1   | 1  | 1   | 1  | 1   | 1 |
| 178S     | Drivescrew  | 9-25-1303-00                 | 2                         | 2  | 2   | 2  | 2   | 2  | 2   | 2 |
| 179      | Solenoid mounting plate   | 8-179-205-01                 | 1                         | 1  | 1   | 1  | 1   | 1  | 1   | 1 |
| 179G     | Grommet (mounting plate)  | 8-147-202-00                 | 3                         | 3  | 3   | 3  | 3   | 3  | 3   | 3 |
| 179S     | Shoulder screw (mounting plate)   | 9-26-1108-00                 | 3                         | 3  | 3   | 3  | 3   | 3  | 3   | 3 |
| 179W     | Washer (mounting plate)   | 8-138-202-00                 | 3                         | 3  | 3   | 3  | 3   | 3  | 3   | 3 |

NOTE: Some brakes manufactured prior to the "-20" series had solenoids which were mounted on (4) rubber shock mounts. Conversion kits are available to replace these mounts. Kit 5-12-9595 replaces 1" diameter by 17/32" high mounts with 1/4-20 studs. Kit 5-12-9594 replaces 1-1/4" diameter by 3/4" high mounts with 5/16-18 studs. Kit 5-12-9593 must replace mounts on serial numbers B-960232 through 69 and B-989748.

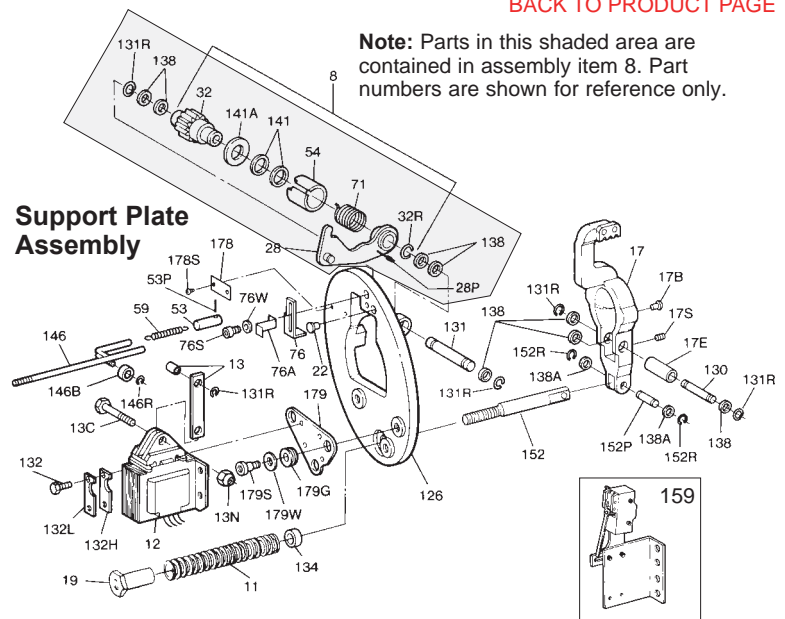

**Solenoid and Coil Assembly**

**Table 3**  
Components of Solenoid and Coil Assemblies

| Item             | Description                  | Part Number  |              |
|------------------|------------------------------|--------------|--------------|
| <b>AC Brakes</b> |                              |              |              |
| 12               | Solenoid Assembly (AC)       | 5-12-5529-00 |              |
| 12A              | No. 9 coil assembly<br>60 Hz | 115 Vac      | 5-96-6901-33 |
|                  |                              | 230 Vac      | 5-96-6902-33 |
|                  |                              | 460 Vac      | 5-96-6904-33 |
|                  |                              | 575 Vac      | 5-96-6905-33 |
|                  |                              | 115/230 Vac  | 5-96-6907-33 |
|                  | 230/460 Vac                  | 5-96-6909-33 |              |

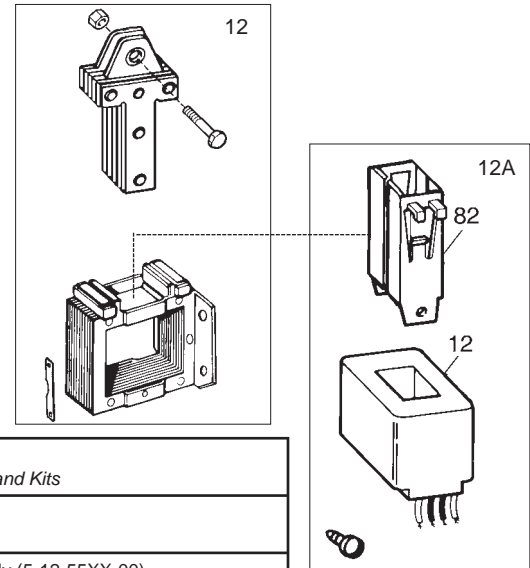

**Table 4**  
Contents of Assemblies and Kits

| Item No. | Description  |
|----------|--|
| 12       | Solenoid assembly (5-12-55XX-00)<br>1 - Plunger<br>1 - Frame<br>2 - Lock plates<br>1 - Solenoid link cap screw<br>1 - Solenoid link nut<br>1 - Cable clamp and screw (DC only)           |
| 12A      | Coil assembly (5-96-69XX-33)<br>1 - Coil<br>2 - Plunger guides<br>2 - Plunger guide screws   |
| 159      | Brake switch kit (5-55-2004-00 or 5-55-2005-00) (brake release interlock switch - N.O.)<br>1 - Microswitch<br>1 - Bracket, microswitch<br>1 - Bracket, mounting<br>1 - Mounting hardware |