

# XVMB2RAGSSB

Pre assembled and pre cabled indicator bank, Harmony XVM, modular tower lights, aluminium, red orange green, 45mm, steady, LED with buzzer, 24V AC DC



## Main

Range of product	Harmony XVM
Product or component type	Pre-assembled and pre-cabled indicator bank
Beacon or indicator bank unit type	3 illuminated units
Component name	XVM
Light source	Green super bright LED with BA 15d base steady signalling Orange super bright LED with BA 15d base steady signalling Red super bright LED with BA 15d base steady signalling
Light block color	Red/orange/green
[Us] rated supply voltage	24 V AC/DC
Indicator bank base type	Base with integrated buzzer
Mounting mode	Vertical

## Complementary

Kit composition	Plastic fixing plate Aluminium support tube Base unit Cover
Mounting diameter	45 mm
Connections - terminals	Flying leads, clamping capacity: 1 x 0.325 mm <sup>2</sup> (AWG 22)
Marking	CE
Mounting support	Aluminium tube
[Ui] rated insulation voltage	250 V conforming to IEC 60947-1
Nominal voltage limit	0.85...1.1 Un conforming to IEC 60947-5-1
Current consumption	15 mA on base unit 43 mA on steady LED unit
[Uimp] rated impulse withstand voltage	4 kV conforming to IEC 60947-1
Fundamental frequency	4 kHz
Net weight	0.453 kg

## Environment

IP degree of protection	IP42 vertical position conforming to IEC 60529
Product certifications	CCC
Standards	IEC 60947-1 IEC 60947-5-1
Ambient air temperature for storage	-25...70 °C
Ambient air temperature for operation	-10...50 °C
Overvoltage category	Class I conforming to IEC 60947-1 Class I conforming to IEC 60947-5-1 Class I conforming to IEC 61140
Protective treatment	TC
Noise level	0...80 dB at 1 m

## Packing Units

Unit Type of Package 1	PCE
Number of Units in Package 1	1
Package 1 Height	5.5 cm
Package 1 Width	8.0 cm
Package 1 Length	54.0 cm
Package 1 Weight	579.0 g
Unit Type of Package 2	S04
Number of Units in Package 2	20
Package 2 Height	30.0 cm
Package 2 Width	40.0 cm
Package 2 Length	60.0 cm
Package 2 Weight	12.9 kg
Unit Type of Package 3	P06
Number of Units in Package 3	80
Package 3 Height	80.0 cm
Package 3 Width	80.0 cm
Package 3 Length	60.0 cm
Package 3 Weight	60.388 kg

## Offer Sustainability

Sustainable offer status	Green Premium product
REACH Regulation	<a href="#">REACH Declaration</a>
EU RoHS Directive	Pro-active compliance (Product out of EU RoHS legal scope)
Mercury free	Yes
China RoHS Regulation	<a href="#">China RoHS Declaration</a>
RoHS exemption information	<a href="#">Yes</a>
Environmental Disclosure	<a href="#">Product Environmental Profile</a>
Circularity Profile	No need of specific recycling operations
WEEE	The product must be disposed on European Union markets following specific waste collection and never end up in rubbish bins

## Contractual warranty

Warranty	18 months
----------	-----------

Pre-Assembled and Pre-Cabled Tower Light with Fixing Base for Mounting on Vertical Support (Support Tube + Metal Bracket)

Dimensions

Below drawing shows the maximum configuration of the product. Select the number of stages according to the product characteristics in order to get b2 dimension.

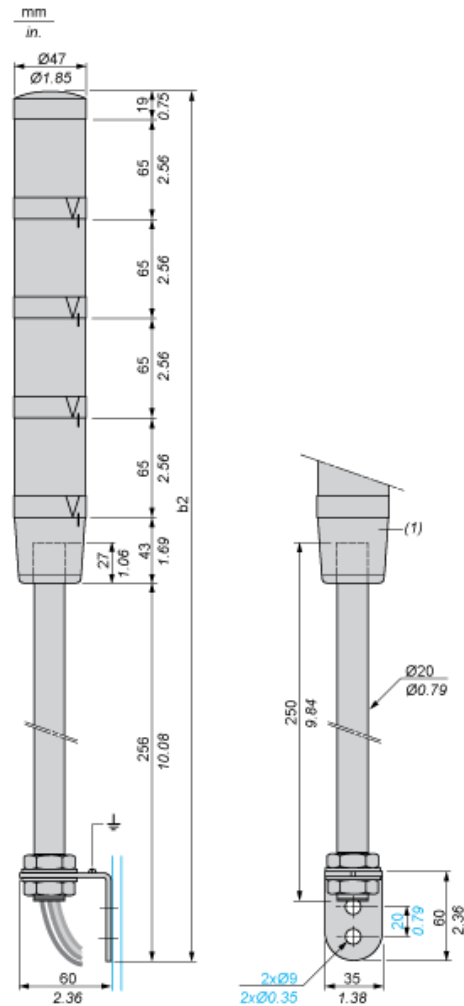

(1) Base unit with or without buzzer.

Number of illuminated units	b2 in mm	b2 in in.
1 unit	383	15.08
2 units	448	17.64
3 units	513	20.20
4 units	578	22.76

---

## Pre-Assembled and Pre-Cabled Tower Light

---

### Wire Colors

4th illuminated unit: yellow wire

3rd illuminated unit: green wire

2nd illuminated unit: white wire

1st illuminated unit: blue wire

Common: black wire

Buzzer (if integrated in base unit): grey wire

---

## Base Unit with Integral Buzzer

---

### Adjustment of Audible Signal

View from above:

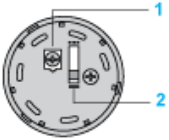

- (1) Volume adjustment potentiometer: 0 to 85 dB. Use either a cross headed or flat tipped screwdriver.
- (2) 2-position selector for type of audible signal: continuous tone or intermittent tone