

# Datasheet

## s.85

### full port ¼"-2" hot forged brass ball valves



#### Quality:

- 24h 100% seal test guaranteed
- Dual sealing system allows valve to be operated in either direction making installation easier
- No metal-to-metal moving parts
- Handle clearly shows ball position
- Silicone-free lubricant on all seals
- Chrome plated brass ball for longer life
- Handle stops on body to avoid stresses at stem

#### Body:

- Hot forged sand blasted, external nickel plated brass body and cap sealed with Loctite® or equivalent thread sealant
- Finest brass according to EN 12165 and EN 12164 (formerly DIN 17660 and UNI 5705-65) specifications

#### Stem:

- Blowout-proof nickel plated brass stem
- Pure PTFE adjustable packing gland and reinforced washer for lower torque and easy maintenance

#### Seals:

- Pure PTFE self-lubricating seats with flexible-lip design

#### PED Directives:

- According to 97/23 CE module A: it cannot be used with dangerous gases in sizes larger than 25mm

#### Threads:

- EN 10226-1, ISO 228 parallel female by female threads

#### Flow:

- Full port to DIN 3357 for maximum flow

#### Handle:

- Geomet® carbon steel handle with thick PVC dip coating. Handle coating offers both thermal and electrical protection

#### Working Pressure:

- 40 Bar (600 PSI)
- non-shock cold working pressure

#### Working Temperature:

- -40°C (-40°F) / +170°C (+350°F)
- Warning: freezing of the fluid in the installation may severely damage the valve

#### Options:

- Stem extension
- T-handle
- Oval lockable handle
- AISI 430 stainless steel handle
- Patented locking device

#### Upon Request:

- AISI 316 stainless steel ball and/or stem
- Glass filled PTFE seals
- Custom Design



**Approved by or in compliance with:**

- GOST-R (Russia)
- Hygiene and epidemic center in Moscow city (Russia)
- UkrSepro (Ukraine)
- RoHS Compliant
- EAC - Declaration of conformity (Russia-Kazakhstan-Belarus)

**NOTE:** Approvals apply to specific configurations/sizes only.

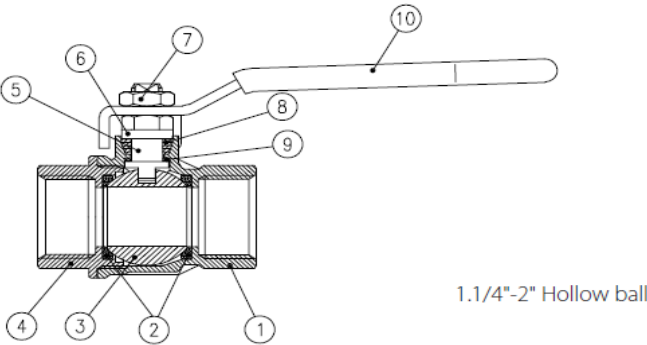

Part Description	Q.ty	Material
1 Nickel plated body (external treatment)	1	CW617N
2 Seat	2	PTFE
3 Chrome plated ball	1	CW617N
4 Nickel plated end cap (external treatment)	1	CW617N
5 Nickel plated stem packing gland design	1	CW617N
6 Nickel plated gland nut	1	CW617N
7 Geomet® nut	1	CB4FF
8 Packing gland seal	1	PTFE
9 Washer	1	PTFE carbon filled 25%
10 Black PVC coated Geomet® steel handel	1	DD11

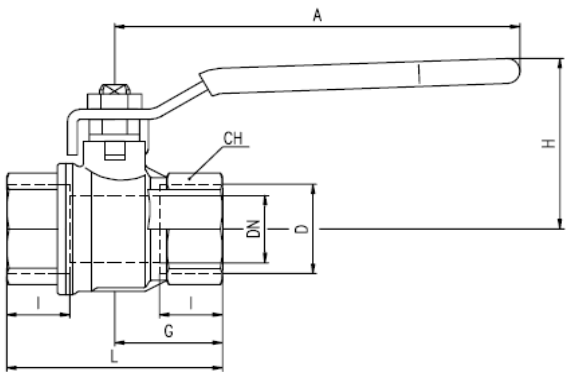

Code	S85B01	S85C01	S85D01	S85E01	S85F01	S85G01	S85H01	S85I01
D (Inch)	1/4	3/8	1/2	3/4	1	1 1/4	1 1/2	2
DN(mm)	8	10	15	20	25	32	40	50
l (mm)	12	12	15,5	17	21	23	23	26,5
L (mm)	45	45	59	64	81	93	102	121
G (mm)	22,5	22,5	29,5	32	40,5	46,5	51	60,5
A (mm)	82	82	100	120	120	158	158	158
H (mm)	39,5	39,5	43	50,5	54,5	76	82	89
CH(mm)	20	20	25	31	40	49	54	68,5

**Pressure-Temperature Chart**

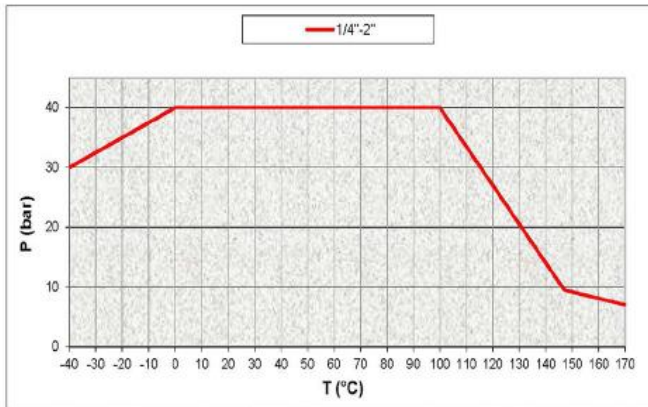

**Pressure Drop Chart**

