



Datasheet

RS PRO Sub-Miniature Pushbutton Switches

Stock number: **175-8XXX / 175-9XXX / 176-09XX**

(Details as follows)

EN



The picture above is for reference only.

Specifications:

CONTACT MATERIAL : Copper over Silver.

RATING : 50mA/DC12V.(max.) (Resistive load)

OPERATING LIFE : Push:30,000 Rotary : 10,000

INSULATION RESISTANCE : 1,00M Ω

CONTACT RESISTANCE : 200m Ω MAX.

WITHSTANDING VOLTAGE: 100V AC for 1min.

OPERATING TEMPERATURE: -20°C to 70°C.

TRAVEL : ABOUT 0.55mm.(push)

OPERATION PRESSURE :

S1 / S3 = Push : 3N+/-1N ; Rotary : 3N+/-1.5N

S2 = Push : 3N+/-1N ; Rotary : 1N+/-0.5N

S4 = Push : 3N+/-1N ; Rotary : 0.8N+/-0.5N(MOM)

S5 = Push : 3N+/-1N ; Rotary : 3N+/-1.5N(ON) ; 0.8N+/-0.5N(MOM)

MODEL NO. FUNCTION LED COLOR

↑ ↑ ↑

MTP

PUSH		C - A		
NO. POLES				
TRAVEL		25°		25°
Rotary	01	ON	NONE	ON
		C-2	N/A	C-1
TRAVEL		30°		0°
Rotary	02	MOM	NONE	ON
		C-2	N/A	C-1
NO. POLES				
TRAVEL		25°		25°
Rotary	03	ON	OFF	ON
		C-2	OPEN	C-1
Rotary	04	MOM	OFF	MOM
		C-2	OPEN	C-1
Rotary	05	ON	OFF	MOM
		C-2	OPEN	C-1

ITEM NO	COLOR
0	Without LED
1	White
3	Red
5	Yellow
6	Green
7	Blue

*

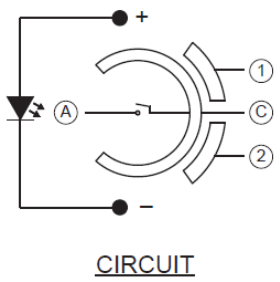

* For other colors information please consult sales representativity.

EXAMPLE:

MTP-01 LED color

RS Part no.

175-8047	MTP-010	175-8080	MTP-035
175-8094	MTP-011	175-9872, 176-0918	MTP-036
175-8093	MTP-013	175-9871, 176-0917	MTP-037
175-8092	MTP-015	175-9870, 176-0916	MTP-040
175-8091	MTP-016	175-9869, 176-0915	MTP-041
175-8090	MTP-017	175-9868, 176-0914	MTP-043
175-8089	MTP-020	175-9867, 176-0913	MTP-045
175-8088	MTP-021	175-9866, 176-0912	MTP-046
175-8087	MTP-023	175-9865, 176-0910	MTP-047
175-8086	MTP-025	175-9864, 176-0909	MTP-050
175-8085	MTP-026	175-9863, 176-0908	MTP-051
175-8071	MTP-027	175-9862, 176-0907	MTP-053
175-8083	MTP-030	175-9861, 176-0906	MTP-055
175-8095	MTP-031	175-9860, 176-0905	MTP-056
175-8081	MTP-033	175-9859, 176-0904	MTP-057

Specifications:

1. Style :

This specification describes " MULTI FUNCTION SWITCH ", mainly used as signal or double switch of electric devices, with the general requirements of mechanical and electrical characteristic °

Operating Temperature Range : -20°C ~ +70°C °

Storage Temperature Range : -30°C ~ +80°C °

2. Electrical Rating : 12VDC/50mA (resistive load) °

3. Type of Actuation : Pushbutton type :SPST + Rotary type:1 pole,3 Position °

4. Test Sequence :

	ITEM	DESCRIPTION	TEST CONDITIONS	REQUIREMENTS
APPEARANCE	1	Visual Examination	By Visual Examination check without and out pressure & testing.	There shall be no defects that affect the serviceability of the product.
ELECTRIC PERFORMANCE	2	Contact Resistance	① Pushbutton: No load under a few times to maintain a certain static weight measurement. ② Rotary: To be measured between the com and contact terminal. ※Measured with a micro-ohm meter at 1 KHz micro-current (at 20 mV / 50 mA).	200mΩ Max.
	3	Insulation Resistance	Measurements shall be made following application of 500 VDC / 100mA potential across terminals and case for 1 minute.	100MΩ min.
	4	Dielectric Withstanding Voltage	①100VAC(50Hz or 60Hz) / between terminals /1minute. ②100VAC(50Hz or 60Hz) /between terminals and frame/ 1minute.	There shall be no breakdown or flashover.

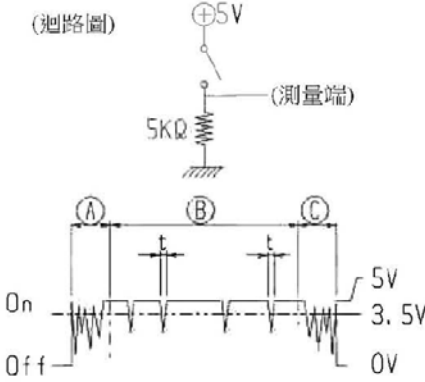
	ITEM	DESCRIPTION	TEST CONDITIONS	REQUIREMENTS
ELECTRIC PERFORMANCE	5	Push: Bounce time	Per EIA-448-1B-1993 (Method 15) to measurement (with load:5V/1mA).	5 ms max.
	6	Rotary: Bounce time	Power-on: 5V / 1mA, Operating Speed: Measured at 60rpm, and Bounce Measured at Voltage Above 1.5V. (迴路圖) 	* A, C unstable area in less than 20 m sec (contact switching area). * Zone B bounces below t = 5 m sec.
OPERATING LIFE	7	Operating Life	Pushbutton part: ① without load. ② operating speed:15-25 cycles/min. ③ operating force: For Operation (specifications limit). ④ Mechanical life time:30,000 Cycles. Rotary part: ① test rating:5VDC /1mA. ② Rate of Operation::15-20 cycles /min. ③ Electronics Life Test:10,000 Cycles. ※POS.1 to POS.3 / 1 Cycles	1. operating force: initial value±30%. 2. rotary force: initial value±30%. 3. Contact Resistance:10Ωmax. 4. Insulation Resistance: 10MΩmin. 5. Dielectric Withstanding Voltage: 100VAC. 6. Contac bounce: initial value. 7. other: Appearance, structure without broken.

	ITEM	DESCRIPTION	TEST CONDITIONS	REQUIREMENTS
HUMIDITY RESISTANCE	8	Resistance High Temperature	Following the test set forth below the sample shall be left in normal temperature and humidity conditions for 1 hour before the measurements are made: ① Temperature : 85±2°C. ② Time : 96 hours.	1. operating force: initial value±30%. 2. rotary force: initial value±30%. 3. Contact Resistance:10Ωmax. 4. Insulation Resistance: 10MΩmin. 5. Dielectric Withstanding Voltage: 100VAC. 6. Contac bounce: initial value. 7. other: Appearance, structure without broken.
	9	Resistance Humidity	Following the test set forth below the sample shall be left in normal temperature and humidity conditions for 1 hour before the measurements are made: ①Temperature:40±2°C. ②Relative Humidity:90-95%. ③Time:96 hours.	
	10	Resistance Low Temperature	Following the test set forth below the sample shall be left in normal temperature and humidity conditions for 1 hour before the measurements are made: ① Temperature : -30±3°C. ② Time : 96 hours.	
	11	Vibration	Shall be vibrated in accordance with Method 201A of MIL-STD-202F ①Frequency: 10-55-10Hz in 1-min/cycle. ②Direction: 3 vertical directions including the directions of operation. ③Test time:2 hours each direction.	
	12	Shock	Shall be shocked in accordance with Method 213B condition A of MIL-STD-202F ①Acceleration; 50g. ②Action time: 11±1m seconds. ③Testing Direction: 6 sides. ④Test Cycle: 3 times in each direction	

Jul.09.2018

MECHANICAL PERFORMANCE	ITEM	DESCRIPTION	TEST CONDITIONS	REQUIREMENTS
	13	Operation pressure	Switch vertical operating direction set, press the site slowly increase the load, the test can not move so far.	Refer to the Drawing
	14	Position of operation	Switch vertical operating direction set, press the site slowly increase the load, measured until the PCB board is turned on until the position.	Refer to the Drawing
	15	Rotating torque	The maximum torque when measuring mode switching.	Refer to the Drawing
	16	Operating member strength (Pressing parts)	Switch vertical operating direction set, press the operating direction of 49N (5kgf) to stand for 5 seconds to exert pressure. (Uniform weight applied to the entire pressing member)	Does not affect the function.
	17	Solderability	The switch terminal foot is immersed in a solder bath (230 ± 2 ° C) for about 3 ± 0.5 seconds with a solution of methanol (JIS K 1501) coated with rosin (JIS K 5902) in a concentration / weight ratio of about 25% rosin.	1. Solder foot solder coverage 75% the above. 2. does not affect the function.

Jul.09.2018

	18	Solder heat resistance	<p>① Reflow test: 150 ± 2 °C thermostat placed 3 minutes later, placed in a 240 ± 2 °C thermostatic bath for 1 minute, then returned to room temperature for measurement. (Once the number of furnaces)</p> <p>② Manual welding test: Torch power: 15W. Torch head: $\phi 1.0$mm. Torch tip temperature: 300 ± 5 °C. Soldering contact time: 3 seconds or less. Welding: no abnormal pressure on the terminal.</p>	No abnormalities in function ;no appearance Of thermal deformation.
--	----	------------------------	--	---

5、Notes :

1. Please set the reflow soldering condition confirming under the actual conditions of mass-production. °
2. Characteristics of switch may change due to the warping of the circuit writing board. Consideration shall be given to the pattern design and layout °
3. This push switch is not washable.
4. This product needs to be connected with the reflow soldering tin. Please pay attention to the position of the plate end and the shell. Do not turn on the automatic plug-in after the switch is installed. Do not start the automatic plug-in due to the danger of the melt infiltrating into the switch.
5. Do not use more than the weight of the standard weight or impact weight of the operating switch, in addition, in order to protect the button area or maintain the operating characteristics, press the pressure evenly, do not focus.
6. In manual soldering, consider that the abnormal pressure of the soldering iron shall not be applied to the tip of the terminal as well do not apply any pressure for more than 1 minute after soldering. °
7. Care shall be taken so that the flux shall not penetrate into the terminal portion.
8. The operating characteristic may change if force is exerted to the top of the cover.

- 9. Consideration shall be taken to the chattering and bouncing in circuit design and soft setting.
- 10. Please confirm the performance on actual operation by simulation with actual environments for high reliability.

11. reflow soldering:

Heating method: far infrared heating up and down.

Temperature measurement method: Please use $\varphi 0.1 \sim 0.2$ CA (K) or CC (T) measurement, the measurement point is the solder joint, with heat-resistant tape.

Soldering Profile:

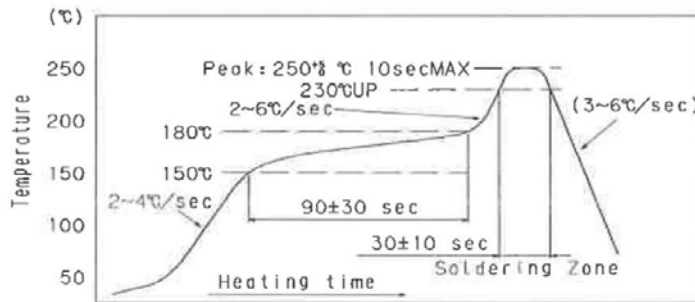

Jul.09.2018

CIRCUIT

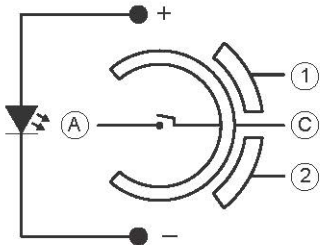

		OPERATING		
PUSH		C - A		
NO. POLES				
TRAVEL		25°		25°
Rotary 01		ON	NONE	ON
		C-2	N/A	C-1
TRAVEL		30°		0°
Rotary 02		MOM	NONE	ON
		C-2	N/A	C-1
NO. POLES				
TRAVEL		25°		25°
Rotary 03		ON	OFF	ON
		C-2	OPEN	C-1
Rotary 04		MOM	OFF	MOM
		C-2	OPEN	C-1
Rotary 05		ON	OFF	MOM
		C-2	OPEN	C-1

Part No. Shown : MTP-01~02

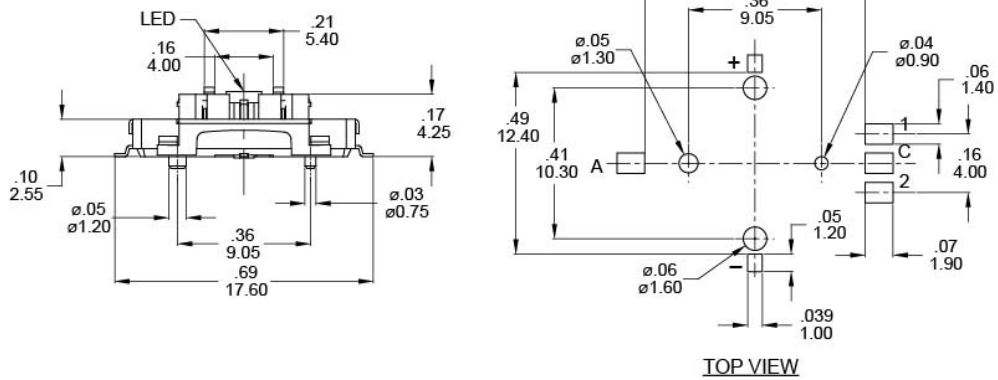
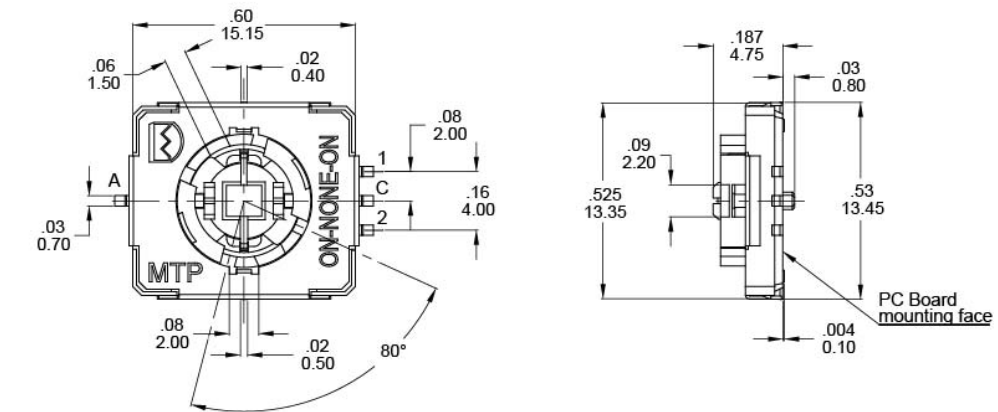

Part No. Shown : MTP-03~05

