

LED WALL LIGHT

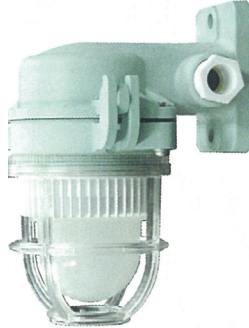

BG SERIES



Key Features

- Complete solution with heat sink, driver and polycarbonate diffuser
- Triac dimming compatible (220-240VAC & 100V-120VAC only)
- Vibration-resistant
- Alternative to 100W incandescent bulb
- Energy savings of up to 90% compared to 100W incandescent bulb
- Long service life of 50,000 hours L70 @ 45°C (Ta)
- Safety, EMC and IEC compliance,

Application

Engine rooms, Low visibility areas, Decks, Warehouses, Yards

Material

Marine grade aluminium alloy with powder coating and PBT fiberglass reinforced body, polycarbonate diffuser and guard

Options

Polycarbonate clear guard (PC)
Polycarbonate red guard (PR)

Weight

1.0Kg

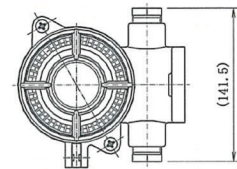
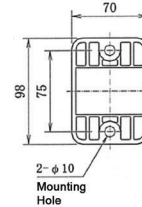
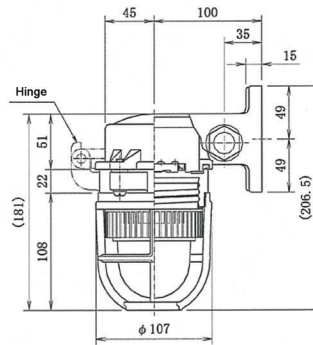
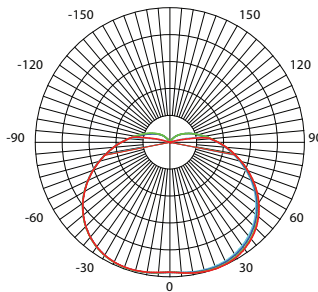

TECHNICAL SPECIFICATIONS



- PC Denotes : Polycarbonate clear guard
- PR Denotes : Polycarbonate red guard

Ideal Replacement:



BH Code	Type	Main Voltage	Power	CCT	Beam Angle	Ambient Temp (Ta)	System Lumen
IGLABGLS10A2PC	BG-LS10A2PC	220V - 240V AC	13W	5000K	160°	-40°C ~ +45°C	900lm
IGLABGLS10A1PC	BG-LS10A1PC	100V - 120V AC	12W	5000K	160°	-40°C ~ +45°C	900lm
IGLABGLS10DPR	BG-LS10DPR	24V DC	10W	5000K	160°	-40°C ~ +45°C	950lm

Also available in other CCT.

