



Datasheet

RS PRO Piezo Audio Indicator

EN RS Stock No: 181-2738



A. SCOPE

This specification applies piezo audio transducer, 1812654

B. SPECIFICATION

No.	Item	Unit	Specification		Condition
1	Operating Volt.	Vp-p	Sine Wave 85	Square Wave 50	Continuous
2	Operating Volt.	Vp-p	Sine Wave 100	Square Wave 60	Intermittent
3	Operating Frequency	KHz	2.0 ~ 4.0		
4	Sound pressure level	dB	85		3m/18Vp-p Square wave at 3.2KHz
5	Sound pressure level	dB	82		1m/2.832Vrms Sine wave at 3.2KHz
6	Electrostatic capacity	uF	0.235 ± 30%		at 120Hz/1V
7	Operating temp.	°C	-40 ~ +105		
8	Storage temp.	°C	-40 ~ +105		
9	Dimension	mm	φ 50.6 x H16.7		See appearance drawing
10	Weight (MAX)	gram	11.5		
11	Material		PBT+30%GLASS UL94V-0 (BLACK)		
12	Terminal		Pin type (Plating Sn)		See appearance drawing
13	Environmental Protection Regulation		RoHS		
14	Storage life	month	6		6 months preservation at room temp. (25±3°C), Humidity40%



C. APPEARANCE DRAWING

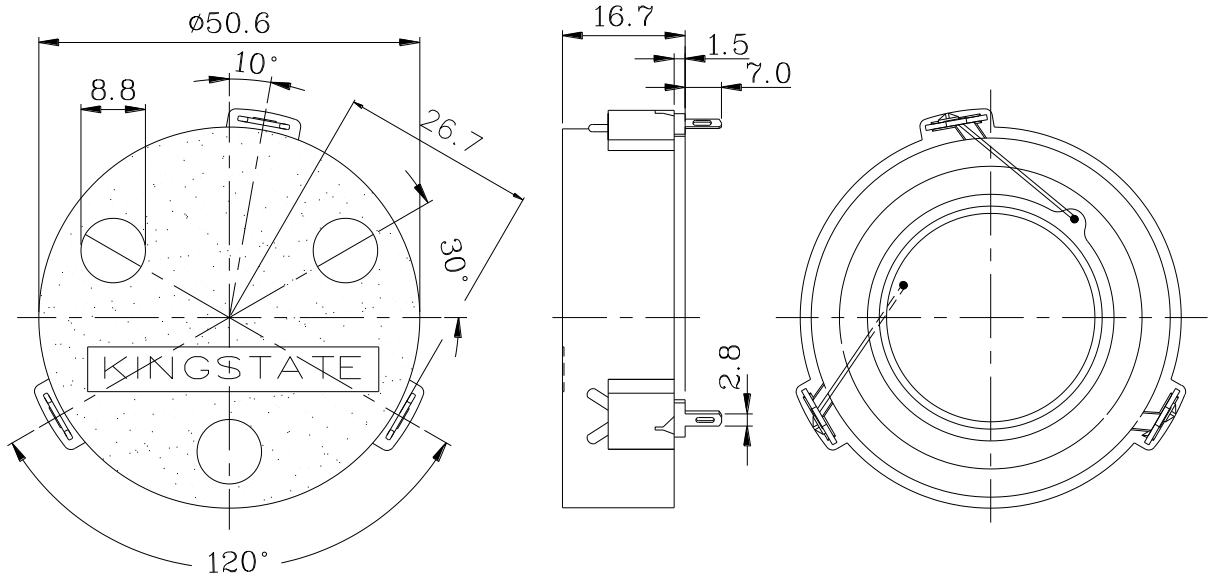

Tol : ± 0.5

Unit: mm

D. TYPICAL FREQUENCY RESPONSE CURVE

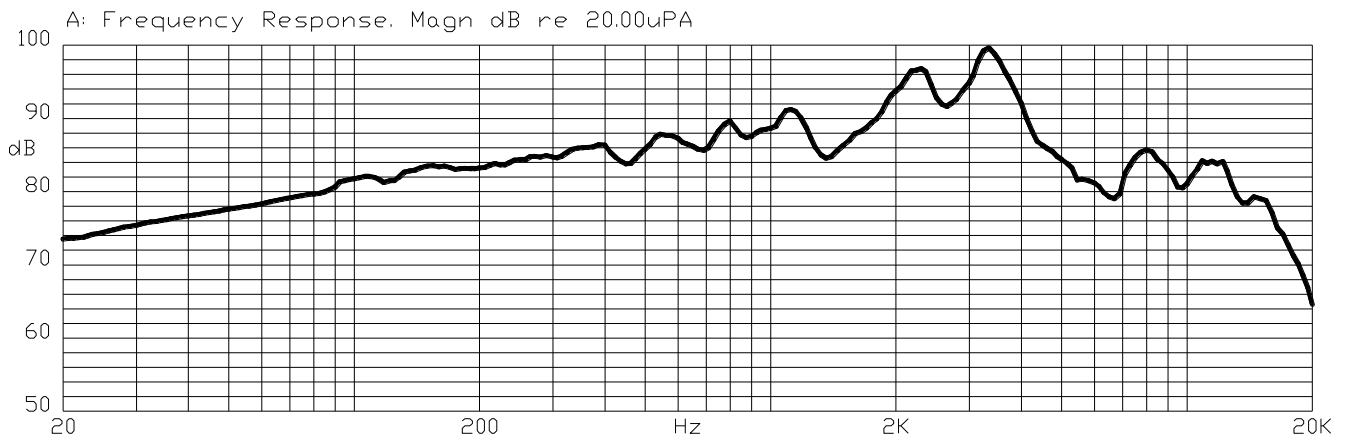

E. MEASURING METHOD

S.P.L. Measuring Circuit

Input Signal: 18Vp-p, 3.2kHz, Square Wave

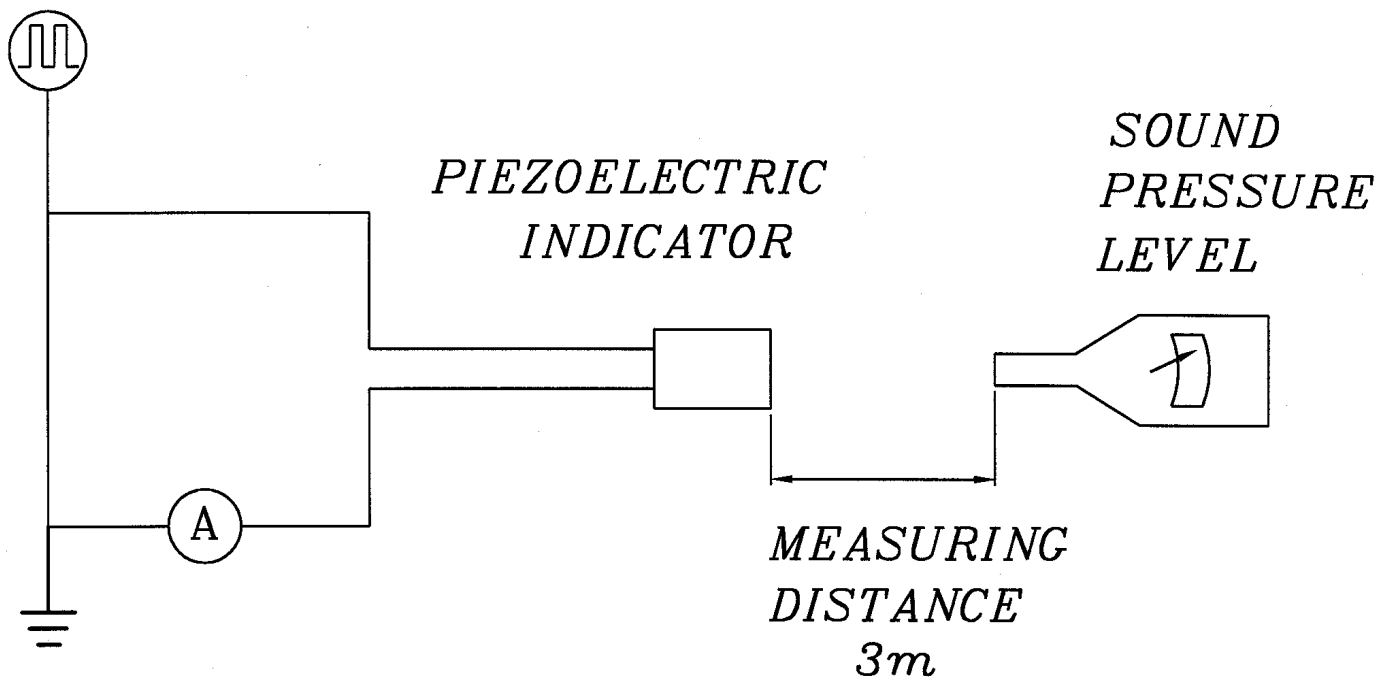

Mic : RION S.P.L meter UC30 or equivalent

S.G : Hewlett Packard 33120A Function Generator or equivalent

F. MECHANICAL CHARACTERISTICS

No.	Item	Test Condition	Evaluation standard
1	Solderability	Lead terminals are immersed in rosin for 5 seconds and then immersed in solder bath of $+270\pm 5^{\circ}\text{C}$ for 3 ± 1 seconds.	90% min. lead terminals shall be wet with solder. (Except the edge of terminal)
2	Soldering Heat Resistance	Lead terminal are immersed up to 1.5mm from sounder's body in solder bath of $+300\pm 5^{\circ}\text{C}$ for 3 ± 0.5 seconds or $+260\pm 5^{\circ}\text{C}$ for 10 ± 1 seconds.	No interference in operation
3	Terminal Mechanical Strength	The force 10 seconds of 9.8N (1.0kg) is applied to each terminal in axial direction.	No damage and cutting off
4	Vibration	Buzzer shall be measured after being applied vibration of amplitude of 1.5mm with 10 to 55hz band of vibration frequency to each of 3 per-pendicular directions for 2 hours.	The value of oscillation frequency/ current consumption should be in 10% compared with initial ones .The SPL should be in $\pm 10\text{dB}$ compared with initial one.
5	Drop test	The part only shall be dropped from a height of 75cm onto a 40mm thick wooden board 3 times in 3 axes (X.Y.Z). (a total of 9 times).	

G. ENVIRONMENT TEST

No	Item	Test Condition	Evaluation standard
1	High temp. test	After being placed in a chamber at +105°C for 240 hours	Being placed for 4 hours at +25°C, buzzer shall be measured. The value of oscillation frequency/ current consumption should be in ±10% compared with initial ones. The SPL should be in ±10dB compared with initial one.
2	Low temp. test	After being placed in a chamber at -40°C for 240 hours	
3	Humidity test	After being placed in a chamber at +40°C and 90±5% relative humidity for 240 hours	
4	Temp. cycle test	<p>The part shall be subjected to 5 cycles. One cycle shall be consist of::</p>	

H. RELIABILITY TEST

No.	Item	Test condition	Evaluation
1	Operating life test	<p>1. Continuous life test 48 hours continuous operation at +90°C with rated voltage applied.</p> <p>2. Intermittent life test A duty cycle of 1 minute on, 1 minutes off, a minimum of 5000 times at room temp.(+25 ±2°C)and rated voltage applied</p>	Being placed for 4 hours at +25°C, buzzer shall be measured. The value of oscillation frequency/ current consumption should be in ±10% compared with initial ones. The SPL should be in ±10dB compared with initial one.

TEST CONDITION.

Standard Test Condition: a) Temperature : +5 ~ +35°C b) Humidity : 45-85%

Judgement Test Condition: a) Temperature : +25 ± 2°C b) Humidity : 60-70%

c) Pressure : 860-1060mbar

c) Pressure : 860-1060mbar