



Soft-start modules



Instruction Leaflet

Size 0.55...2.2 kW
1.1...5.5 kW

RS stock no. 212-8683
212-8699

Figure 1 Connection diagram

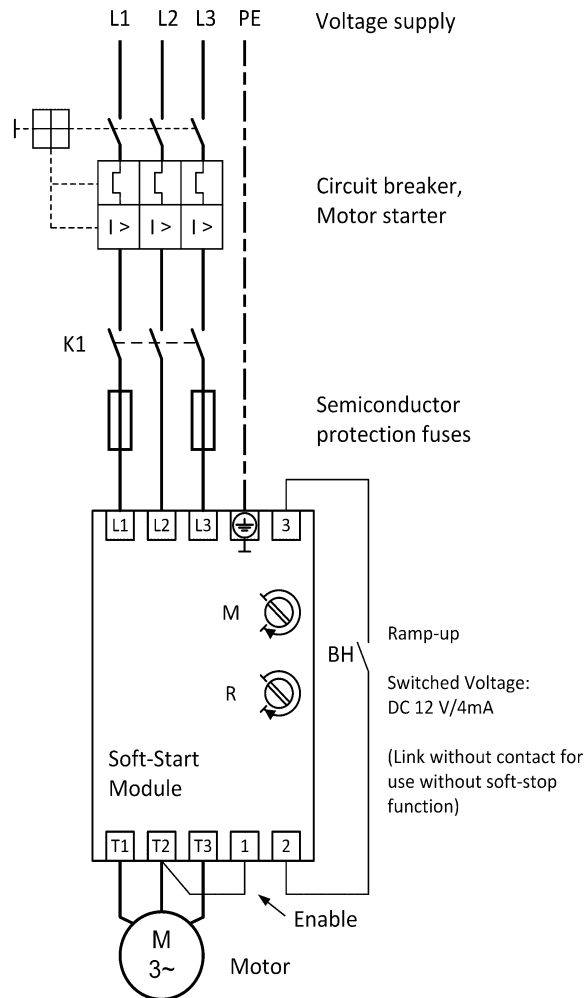

General

The problems associated with starting shock of DOL started induction motors can be cured with the help of **RS** Soft-Start Modules. **RS** Soft-Start Modules are suitable for use with three-phase induction motors up to 5.5 kW. The compact size and easy connection of these modules makes retrofitting simple. The adjustments of switch-on torque and run-up ramp time enable easy adjustment for a particular application.

This gives the user the benefits of:

- Mechanical**
 - Reduced cost of transmission components
 - Low adjustable starting torque
- Conveyer belts**
 - Falling over, banging or slipping of products eliminated
- Electrical**
 - Reduced starting current

Adjustment procedure

1. Set potentiometer M (starting torque) and potentiometer R (run-up ramp), both fully counter clockwise.
2. Increase potentiometer M in a clockwise direction until the switch-on torque is enough to start the drive immediately on connection of the power.
3. Increase potentiometer R in a clockwise direction until the drives ramps up smoothly. Turn as far clockwise as possible whilst retaining a smooth soft-start characteristic. The module is correctly adjusted if the internal bridging relay is heard to close as soon as the drive has ramped up.

Adjustment ranges

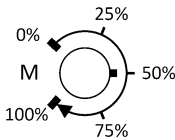
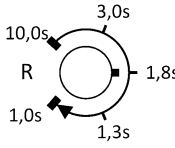
Designation, Meaning	Scaling	Explanation
M - Switch-on torque		Rated torque
R - Ramp		Time until bridging relay closes

- Suggestion for initial setting (initial factory setting)
The above values are approximate values only

Control inputs

Signal Terminal	open	closed	Remarks
BF - Command "Enable" T2-1	Inhibited	Enable	Caution, supply voltage
BH - Command "Ramp-up" 2-3	Ramp-down	Ramp-up	Switched voltage DC12V

Indicating LEDs

	dark	light
ME - Monitoring signal "In operation"	Fault, not enabled, no supply	In operation
MH - Monitoring signal "End of ramp"	Any other condition	End of ramp

Technical specifications

Electrical	RS Stock no. 212-8683	RS Stock no. 212-8699
Rated Voltage	3AC 400 V +10-15 %	
Rated Frequency	50/60 Hz ±2 %	
Rated Motor Power	2.2 kW	5.5 kW
Min. Motor Power	0.55 kW	1.1 kW
Rated current	5.5 A	12 A
Max starting duty* at 4 I _N : - side-by-side - intermediate spacing 10 mm	10 % 12 %	4 % 5 %
EN 60947-4-2: - Utilization category - Form designation	5.5 A:AC-53b: 4-10: 90 1 (Soft starting with soft stop)	12 A: AC-53b: 4-10: 240 1 (Soft starting with soft stop)
Loss after ramp up	3 W	4 W
Overvoltage category to EN 60664-1/ Rated insulation voltage to PE	III / AC 230 V	only for use with TT/TN supplies with earthed neutral
Terminals	1.0...2.5 mm ² multistrand with end ferrules	
D style semiconductor protection fuse type gR, recommended RS Stock No. (for prospective short-circuit current up to 50 kA)	20 A 422-551	35 A 421-520

* Starting duty refers to the percentage of operating time the RS Soft-Start Module is performing soft starting.

Environment	Permissible temperatures:	Operation: 0... +40 °C Storage: -25... +55 °C Transport -25... +70 °C	
	Climatic conditions:	Class 3K3 to EN 60721-3-3 (5...85 % relative humidity). The cooling air must have little dust and be non-corrosive and non-flammable.	
	Pollution:	Degree 2 to EN 60664-1: Dry non conducting dust or particles, infrequent light condensation when switched off permissible	
	Altitude:	max. 2000 m NN above sea level, ≥ 1000 m: 1,5 % / 100 m power derating	
Safety	Relevant standards:	EN 60947-4-2, EN 50178)	
	Protective class:	I to EN 61140 i.e. basic insulation with PE connection (protective earth). The user is responsible for the PE connection.	
	IP Protection:	IP20 to EN 60529 Finger protection	
	Signal and control terminals:	The control circuit is protected by basic insulation from the supply voltage. Any components connected to the control circuit (e.g. external push buttons) must be protected against direct contact by additional insulation.	
Installation	Weight (approx.)	450 g	
	Dimensions:	Height	75 mm
		Width	45 mm
		Depth	120 mm
General	Technical data subject to change without notice		

Planning the installation

Intended use:

RS Soft Start Modules are specifically designed for use with three-phase induction motors.

RS Soft-Start Modules are equipment to be mounted in a suitable enclosure (e.g. equipment cabinet) as part of a machine or electrical system.

The technical data as well as information concerning the supply conditions are to be taken from rating plate and from this data sheet and must be strictly observed.

RS Soft-Start Modules should not be used in conjunction with capacitive loads as damage to the power semiconductors can occur. However, power factor correction at the module input is allowed.

Starting performance:

The achievable soft-start characteristic is influenced by the inertia and friction of the load. Run-up times of a few seconds are only possible if the load has significant inertia.

Voltage supply system:

To meet the requirements of the LOW-VOLTAGE DIRECTIVE these **RS** Soft-Start Modules may only be used with earthed neutral TT/TN supply systems.

Short-circuit protection of controller:

Fast semiconductor fuses are required for protection of the **RS** Soft-Start Module against short circuits on the output terminals of the controller (see Technical Data).

Wiring protection:

Short-circuit and overload protection of the wiring corresponding to the size of cable used (e.g. as in EN 60439-1, EN 60204-1 for machines) must be provided for. A circuit breaker, motor starter, or additional fuses are required.

Thermal considerations:

RS Soft-Start Modules are designed for continuous operation with motors up to the indicated power. Overload protection of the controller and the motor must be provided for. Suitable protection can be provided by a thermal overload relay, a motor starter or thermistor protection of the motor. Thermistor motor protection is recommended for motors with frequent starting.

Values of starting duty as in the Technical Data should not be exceeded (check spacing).

EN 60947-4-2:

EN 60947-4-2 is a standard for Soft-Start Modules. Information on the following data must be provided:

- Utilization category: 12 A: AC-53b: 2.5-15: 110;
with 12 A: Rated current I_N
AC-53b: Soft start with bypass during running
2.5-15: Max. starting current is 2.5 I_N for 15 s
110: Minimum time [s] between a completed
or a new soft-start at maximum starting duty
- Form designation: 1 i.e. Soft start with soft stop

Pole-change motors:

Reset times of 0.25 s must be allowed for.

The following alternatives can be used for fast changing between speeds:

- Allow for reset time as above
- Provide a soft starter for each winding

Insulation tests:

The use of test equipment with a high voltage (e.g. Megger) can damage the module. Remove all connections to the soft-start modules before using such equipment.

Interference suppression:

When opening contactor or relay coils, or electric brakes, high energy R.F. interference can occur. In extreme conditions this can result in a malfunction of the **RS** Soft-Start Module. For this reason, the coils should be fitted with suitable interference suppressors:

- DC coils: Suppressor diodes
- AC coils: RC-suppressors

Obtaining maximum immunity:

Control inputs and outputs should be wired as short as possible and away from supply, motor or control cables which could carry significant interference. A direct connection to equipment external to the metal enclosure should not be made.



Warnings and safety information



In operation electronic **RS** Soft-Start Modules, depending on their degree of protection, may have live, uninsulated and hot surfaces.

In case of improper use, incorrect installation or maloperation, there is a danger of serious personal injury and damage to property.

These electronic **RS** Soft-Start Modules can affect the movement of dangerous machinery or moving constructions. The following safety precautions must be taken before commissioning:

- Provide adequate means of preventing persons from coming within the dangerous areas of machinery or moving constructions
- Verify that all measures to comply with the EMC DIRECTIVE are complied with.
- Verify if all requirements of the LOW-VOLTAGE DIRECTIVE are adhered to.
- Verify that all requirements of the MACHINERY DIRECTIVE are adhered to and that safety-relevant equipment (e.g. EMERGENCY STOP) is functioning correctly.

The successful and safe operation of this equipment is dependent on proper transport, storage, planning and as installing well as commissioning. Hazardous voltages are present in this electrical equipment during operation.

Equipment showing transport or other damage, or with insulating distances altered must not be used.

Never operate with the cover removed. Non-observance of the warning or safety instructions can result in severe personal injury or property damage.

Only *qualified trained persons* may work in an enclosure on or near these controllers. For the purpose of this documentation a "*qualified trained person*" is one who is familiar with the technical data, recommendations for planning and installing, commissioning instruction and recommended connections contained herein and the hazards involved. In addition, this person has the following qualifications:

- Is trained in the requirements to comply with the EMC DIRECTIVE
- Is trained in the requirements to comply with the LOW-VOLTAGE DIRECTIVE
- Is trained in the requirement of the MACHINERY DIRECTIVE (e.g. EN 60204-1)
- Is trained and authorized to energize, de-energize, clear, ground and tag circuits and equipment in accordance with established safety practices
- Is trained in the appropriate wiring and installation regulations including local regulations where applicable.
- Is trained in the proper care and use of protective equipment in accordance with established safety practices
- Is trained in rendering first aid

Suitable standards (IEC 364 or CENELEC 384 or DIN VDE 0100 and IEC-Report 664 or DIN 0110) are to be used to establish if a person is suitably qualified.

EC directives and regulations

'CE' marking

The 'CE' marking of the electronic RS Soft-Start Modules is at the date at which this Product Manual is issued valid for the EU DIRECTIVES

- 2014/30/EU EMC DIRECTIVE
- 2014/35/EU LOW-VOLTAGE DIRECTIVE

Manufacturers of apparatus and machines sold as functional units are fully responsible for issuing a Declaration of Conformity and applying the 'CE' mark.

EMC directive

RS Soft-Start Modules are components with a function which is determined by the construction and layout of the complete installation. It is the responsibility of user to ensure that the EMC DIRECTIVE is adhered to. The following standards are particularly relevant:

Product Standard for	EN 60947-4-2
AC semiconductor motor starters:	
RF Interference:	EN 55011
Immunity:	EN 61000-4-2/-3/-4/-5

Declaration of Conformity:

A Declaration of Conformity declaring conformance of these electronic RS Soft-Start Modules with the EMC DIRECTIVE based on the Product Standard EN 60947-4-2 which references the above standards for RF Interference and Immunity is available on request. Particular reference should be made to the instructions for planning the installation concerning interference suppression and immunity.

During continuous operation Interference Limit B for use in residential, commercial and light industry supplied directly from public electricity supply (including public buildings, banks, hospitals etc.) is adhered to.

Other important information:

The user should be conversant with the following issues:

- EMC 'CE' Responsibility, and in particular the CEMEP recommendations for application of the EMC DIRECTIVE to electronic power drive equipment
- Limit values of permissible EMC interference when used in:
 - Residential areas (Class B)
 - Industrial areas with own transformer station (Class A)
- Responsibility of manufacturers of apparatus and machines sold as complete functional units

Low-voltage directive

It is the responsibility of the user to ensure that the complete installation adheres to the LOW-VOLTAGE DIRECTIVE. The following standards should be considered as is appropriate:

- Product Standard for AC semiconductor motor starters: EN 60947-4-2
- Installation with power electronic equipment: EN 50178
- Installation regulations in electrical enclosures: EN 60439-1
- Electrical equipment of machines: EN 60204-1

Declaration of Conformity:

A Declaration of Conformity declaring conformance of these electronic RS Soft-Start Modules with the LOW-VOLTAGE DIRECTIVE based on the product standard EN 60947-4-2 and EN 50178 is available on request. Particular reference should be made to the Technical Data and to the instructions for planning the installation.

Machinery directive

Electronic RS Soft-Start Modules are components to be incorporated into machinery and may not be operated alone. Pay particular reference to the following standard:

- Electrical equipment of machines EN 60204-1

Disposal

During transport, our products are protected by packaging as far as necessary. The packaging consists entirely of environmentally compatible material that should be taken for central disposal as valuable secondary raw materials.

Contact the relevant Local Authority department to find out about disposal, including disposal of old appliances.

Table for fault finding

Fault	Possible cause	Cure
1. Motor does not start	<ul style="list-style-type: none"> ● Enable link missing ● Command "Ramp-up" BH not activated 	<ul style="list-style-type: none"> - Connect enable link T2-1 - Connect BH
2. Drive accelerates in an uncontrolled manner	<ul style="list-style-type: none"> ● End of ramp with full voltage comes too early ● Controller faulty 	<ul style="list-style-type: none"> - Adjustment M/R too high, turn M/R ccw. - Return controller to supplier
3. Controller suspected to be faulty (e.g. following short circuit)	<ul style="list-style-type: none"> ● LEDs do not light even though supply present and enable and BH links bridged. ● Power semiconductors damaged. Check the terminals do not have a short circuit using an Ω-meter. 	<ul style="list-style-type: none"> - Return controller to supplier
4. Everything tried without success		<ul style="list-style-type: none"> - Send circuit diagram of application and potentiometer settings by fax to your supplier

The information provided in RS instruction leaflet is believed to be accurate and reliable, however RS Components assumes no responsibility for inaccuracies or omissions, or for the use of this information, and all use of such information shall be entirely at the user's own risk.

No responsibility is assumed by RS Components for any infringements of patents or other rights of third parties which may result from its use.

Specifications shown in RS Components instruction leaflets are subject to change without notice.

RS Components Ltd., Birchington Road, Corby, NN179RS, United Kingdom
 RS Components GmbH, Mainzer Landstraße 180, 60327 Frankfurt/Main, Germany