

▼ Shown from left to right: EP-206, EP-108



- Patented 'Safety Cage' jaw retention system
- Roll threaded shafts for less effort when applying high torque
- Slim tapered jaws for improved gripping in tight spots
- Available in 2 and 3 jaw design and inside and outside pulling configuration
- More efficient pulling, as one man can do the job where manual pullers often require two operators.



◀ EP-204 2 jaw puller positioned to pull a water pump drive pulley.

For Safer and Faster Pulling



Long Jaws

Long Jaws are used to increase the reach and spread of manual pullers. They maintain the same pulling capacity as the standard jaws, but reduce clamping force to 25%.

Page: 151



Shaft Attachments

Shaft protectors and extenders are live centers that fit over the standard puller shaft for tip protection and additional reach.

Page: 151

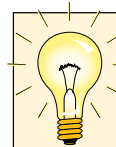

Application Tip

Because of the unique safety cage design, Posi Lock® pullers will grip on surfaces where normal pullers would slip off; e.g. tapered bearings.

Posi Lock® Mechanical Grip Pullers

External Posi Lock® Pullers

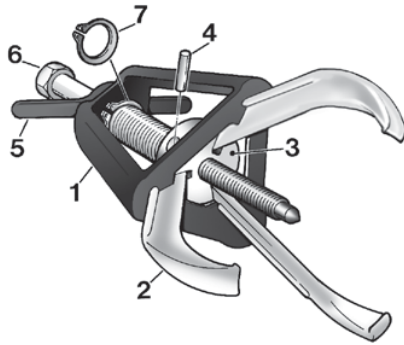

- 1 Patented 'Safety Cage' guides jaws, holding them securely onto the part.
- 2 Durable forged jaws provide positive grip.
- 3 Jaw head provides pivot and reaction point for jaws.
- 4 Pin, for easy jaw removal and replacement.
- 5 T-handle provides control of the puller jaws.
- 6 Drive bolt with rolled threads for increased force with reduced input torque.
- 7 Snap-ring retains cage to drive bolt and provides quick removal for easy service.

EP EPP Series



Capacity:

2 - 40 ton

Maximum Reach:

101 - 355 mm

Spread Range:

12 - 635 mm

▼ QUICK SELECTION CHART EXTERNAL PULLERS

For quick technical information see next page.

Number of Jaws	Maximum Reach (mm)	Spread (min. - max.) (mm)	Capacity (ton (kN))	Model Number	Center Bolt Diameter (mm)	 (kg)
2	101	12 - 127	2 (17)	EP-204	14	1,4
3	101	12 - 127	5 (45)	EP-104	14	1,8
2	152	12 - 178	6 (53)	EP-206	16	3,2
3	152	12 - 178	10 (89)	EP-106	16	3,6
2	203	19 - 304	12 (106)	EP-208	20	5,4
3	203	19 - 304	17 (151)	EP-108	20	6,4
2	245	25 - 381	14 (124)	EP-210	20	5,9
3	245	25 - 381	20 (178)	EP-110	20	7,3
2	304	63 - 457	25 (222)	EP-213	29	17,2
3	304	63 - 457	30 (267)	EP-113	29	20,0
2	355	76 - 635	35 (311)	EP-216	31	25,8
3	355	76 - 635	40 (356)	EP-116	31	30,8



IMPORTANT!

Always wear Safety Goggles while using pullers.

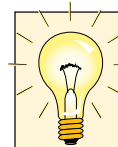

Application Tip

In determining the correct manual puller capacity for your application, use the following rule:

The center bolt diameter of the puller should be at least 1/2 the diameter of the shaft being pulled on.

Example:

A part being pulled from a shaft with a diameter of 38 mm would require a puller with a center bolt diameter of at least 19 mm.

Internal Posi Lock® Puller

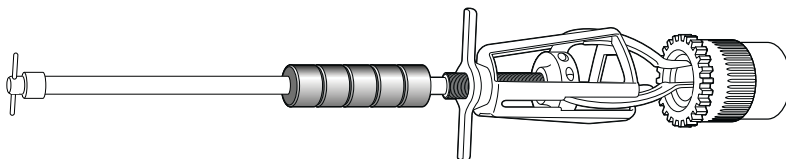

▼ QUICK SELECTION CHART INTERNAL PULLERS

Number of Jaws	Maximum Reach (mm)	Spread min. - max. (mm)	Jaw Style	Model Number	Jaw Length (mm)	 (kg)
3	168	14 - 101	Standard	EPPMI-6	168	3,9
	218	25 - 133	Long		218	3,9

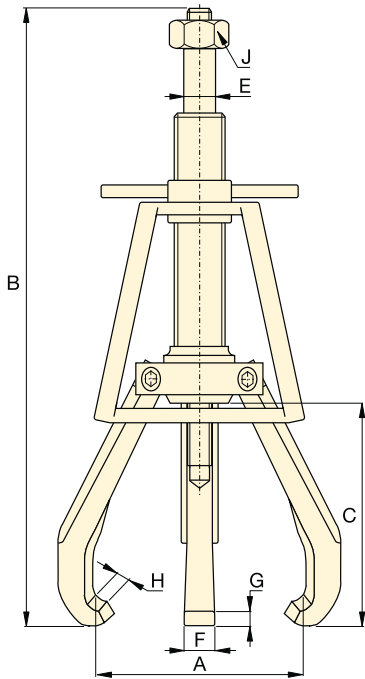

**2 and 3 Jaw External Puller
EP-Series**

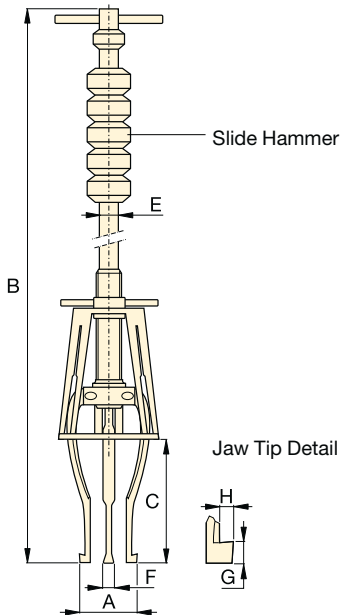

**Internal Puller
EPPMI-6**

▼ **QUICK SELECTION CHART EXTERNAL PULLERS**

Number of Jaws	Maximum Reach (mm)	Spread min. - max. (mm)	Capacity ton (kN)	Model Number	Center Bolt Diameter (mm)	Maximum Torque (Nm)
2	101	12 - 127	2 (17)	EP-204	14	27
3	101	12 - 127	5 (45)	EP-104	14	54
2	152	12 - 178	6 (53)	EP-206	16	102
3	152	12 - 178	10 (89)	EP-106	16	176
2	203	19 - 304	12 (106)	EP-208	20	203
3	203	19 - 304	17 (151)	EP-108	20	298
2	245	25 - 381	14 (124)	EP-210	20	237
3	245	25 - 381	20 (178)	EP-110	20	373
2	304	63 - 457	25 (222)	EP-213	29	644
3	304	63 - 457	30 (267)	EP-113	29	814
2	355	76 - 635	35 (311)	EP-216	31	1085
3	355	76 - 635	40 (356)	EP-116	31	1153

▼ **QUICK SELECTION CHART INTERNAL PULLERS**

Number of Jaws	Maximum Reach (mm)	Spread min. - max. (mm)	Jaw Style	Model Number	Jaw Style (mm)	Slide-hammer weight (kg)
3	168	14 - 101	Standard	EPPMI-6	168	1,1
	218	25 - 133	Long		218	1,1

Posi Lock® Mechanical Pullers



Shaft Attachments

Shaft protectors and extenders are live centers that fit over the standard puller shaft for tip protection and additional reach.



Long Jaws

Long Jaws are used to increase the reach and spread of pullers. They maintain the same pulling capacity as the standard jaws, but reduce clamping force to 25% of rating.

EP EPP Series



Capacity:

2 - 40 ton

Maximum Reach:

101 - 355 mm

Spread Range:

12 - 635 mm



▼ SHAFT ATTACHMENTS

Length (mm)	Dia- meter (mm)	Increases Center Bolt Length (mm)	Model Number
25	19	9	EPP-4
50	19	38	EPX-4
31	22	12	EPP-6
50	22	38	EPX-6
31	25	12	EPP-10
50	25	38	EPX-10
50	35	21	EPP-1316

▼ LONG JAWS

Spread min. - max. (mm)	Max. Reach (mm)	Model Number
57 - 381	245	EP-11054
38 - 558	400	EP-11054L
38 - 762	508	EP-11354L
25 - 133	218	EP-10554L*

* for EPPMI-6 only

Dimensions (mm)								Model Number	Optional Accessories		
Spread min. - max. A	Overall Length B	Max. Reach C	Center Bolt Diam. E	Jaw Width F	Tip Clearance G	Tip Depth H	Hex Socket Size (inch) J				
12 - 127	245 - 323	101	14	15	4,1	4,6	7/8	EP-204	EPP-4	EPX-4	-
12 - 127	245 - 323	101	14	15	4,1	4,6	7/8	EP-104	EPP-4	EPX-4	-
12 - 178	323 - 476	152	16	19	8,1	6,1	1 ¹ / ₁₆	EP-206	EPP-6	EPX-6	-
12 - 178	323 - 476	152	16	19	8,1	6,1	1 ¹ / ₁₆	EP-106	EPP-6	EPX-6	-
19 - 304	412 - 615	203	20	22	6,4	9,1	1 ¹ / ₄	EP-208	EPP-10	EPX-10	EP-11054
19 - 304	412 - 615	203	20	22	6,4	9,1	1 ¹ / ₄	EP-108	EPP-10	EPX-10	EP-11054
25 - 381	489 - 736	245	20	25	6,4	9,1	1 ¹ / ₄	EP-210	EPP-10	EPX-10	EP-11054L
25 - 381	489 - 736	245	20	25	6,4	9,1	1 ¹ / ₄	EP-110	EPP-10	EPX-10	EP-11054L
63 - 457	660 - 965	304	29	31	12,7	9,7	1 ¹¹ / ₁₆	EP-213	EPP-1316	-	EP-11354L
63 - 457	660 - 965	304	29	31	12,7	9,7	1 ¹¹ / ₁₆	EP-113	EPP-1316	-	EP-11354L
76 - 635	800 - 1155	355	31	36	13,5	11,7	1 ¹³ / ₁₆	EP-216	EPP-1316	-	EP-11654L
76 - 635	800 - 1155	355	31	36	13,5	11,7	1 ¹³ / ₁₆	EP-116	EPP-1316	-	EP-11654L

Note: Overall length (B) is dependent on position of center bolt.

Dimensions (mm)							Model Number
Spread min. - max. A	Overall Length B	Max. Reach C	Slide Rod Dia. E	Jaw Width F	Tip Clearance G	Tip Depth H	
14 - 101	736	168	14,2	8	3,0	1,5	EPPMI-6
25 - 133	787	218	14,2	8	7,6	4,6	



Always wear Safety Goggles while using pullers.