

* = Conical form tapering downward.
 Untoleranced dimensions per GTA 13/5 DIN 1688

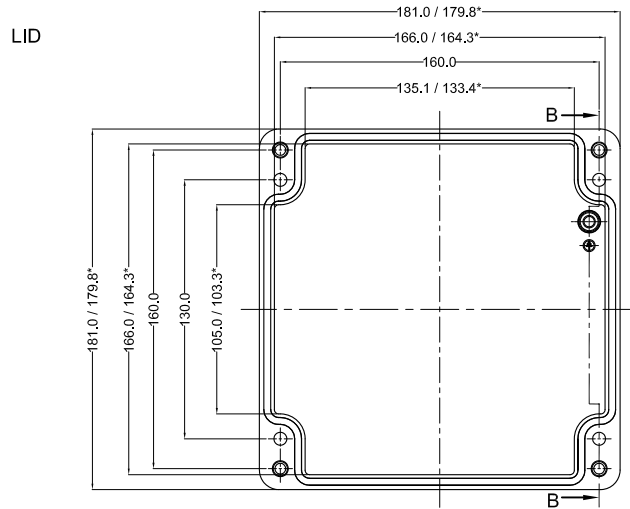

Cylinder Screw
 M6 x 35/10 similar to DIN 84

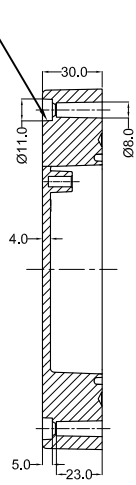

SECTION B-B

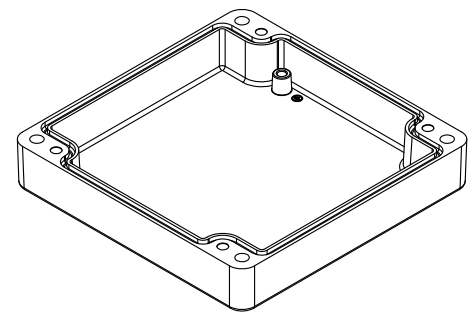

OPTIONAL ACCESSORIES		
PART NAME	QTY.	AVILABILITY
MOUNTING PLATE	1	Y
EXTERNAL HINGE	2	Y
INTERNAL HINGE	2	Y
MOUNTING BRACKETS	4	Y
NEOPRENE/SILICON GASKET	1	Y
DIN RAIL TS15	-	N
DIN RAIL TS35	1	Y

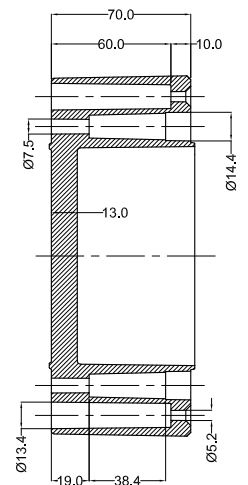
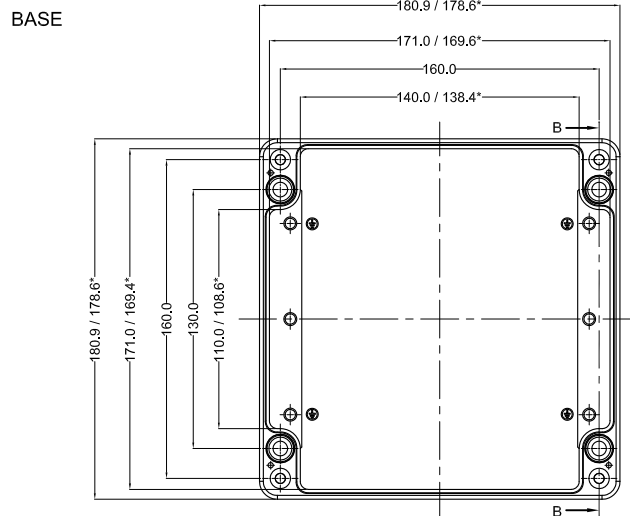

SECTION B-B

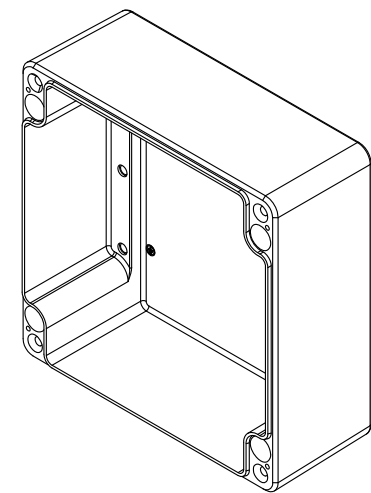

QUANTITY	MATERIAL :-	MACH.NAME	DATE	SIGN	NAME	
-	Alsi12 Din230	-	30/04/18		RRPL	DESIGN
			30/04/18		MANOJ	DRAWN
			30/04/18		PAWAN	CHECKED
					S . D .	APPROVED
TOLERANCE		WEIGHT: FINISH:	TITLE :-			
±0.2	DIMENSIONS	- NATURAL	JUNCTION BOX			
±0.2	HOLES		180 x 180 x 100			
±1.0°	ANGLES	RJ 28	SCALE			
ALL DIMENSION ARE IN MM						