

XB5AG41C0

Selector switch, Harmony XB5, key 455 2 pos stay put key release cp grey



Main

| | |
|-------------------------------|--|
| Range of product | Harmony XB5 |
| Product or component type | Selector switch |
| Device short name | XB5 |
| Bezel material | Plastic colour plated grey |
| Head type | Standard |
| Mounting diameter | 22 mm |
| Sale per indivisible quantity | 1 |
| Shape of signaling unit head | Round |
| Type of operator | Stay put |
| Operator profile | Black key switch |
| Operator position information | 2 positions 90° |
| Type of keylock | Key 455 |
| Contacts type and composition | 1 NO |
| Contact operation | Slow-break |
| Connections - terminals | Screw clamp terminals, $\leq 2 \times 1.5 \text{ mm}^2$ with cable end conforming to IEC 60947-1 Screw clamp terminals, $\geq 1 \times 0.22 \text{ mm}^2$ without cable end conforming to IEC 60947-1 |

Complementary

| | |
|--|--|
| Height | 42 mm |
| Width | 30 mm |
| Depth | 96 mm |
| Terminals description ISO n°1 | (13-14)NO |
| Net weight | 0.831 kg |
| Resistance to high pressure washer | 7000000 Pa at 55 °C, distance : 0.1 m |
| Key withdrawal position | In any position |
| Contacts usage | Standard contacts |
| Positive opening | Without |
| Torque value | 0.14 N.m NO changing electrical state |
| Mechanical durability | 1000000 cycles |
| Tightening torque | 0.8...1.2 N.m conforming to IEC 60947-1 |
| Shape of screw head | Cross compatible with Philips no 1 screwdriver Cross compatible with pozidriv No 1 screwdriver Slotted compatible with flat Ø 4 mm screwdriver Slotted compatible with flat Ø 5.5 mm screwdriver |
| Contacts material | Silver alloy (Ag/Ni) |
| Short-circuit protection | 10 A cartridge fuse type gG conforming to IEC 60947-5-1 |
| [I _{th}] conventional free air thermal current | 10 A conforming to IEC 60947-5-1 |
| [U _i] rated insulation voltage | 600 V (pollution degree 3) conforming to IEC 60947-1 |
| [U _{imp}] rated impulse withstand voltage | 6 kV conforming to IEC 60947-1 |
| [I _e] rated operational current | 3 A at 240 V, AC-15, A600 conforming to IEC 60947-5-1 6 A at 120 V, AC-15, A600 conforming to IEC 60947-5-1 0.1 A at 600 V, DC-13, Q600 conforming to IEC 60947-5-1 0.27 A at 250 V, DC-13, Q600 conforming to IEC 60947-5-1 0.55 A at 125 V, DC-13, Q600 conforming to IEC 60947-5-1 1.2 A at 600 V, AC-15, A600 conforming to IEC 60947-5-1 |

The information provided in this documentation contains general descriptions and/or technical characteristics of the performance of the products contained herein. This documentation is not intended as a substitute for and is not to be used for determining suitability or reliability of these products for specific user applications. It is the duty of any such user or integrator to perform the appropriate and complete risk analysis, evaluation and testing of the products with respect to the relevant specific application or use thereof. Neither Schneider Electric Industries SAS nor any of its affiliates or subsidiaries shall be responsible or liable for misuse of the information contained herein.

| | |
|------------------------|--|
| Electrical durability | 1000000 Cycles, AC-15, 2 A at 230 V, operating rate <3600 cyc/h, load factor: 0.5 conforming to IEC 60947-5-1 appendix C 1000000 Cycles, AC-15, 3 A at 120 V, operating rate <3600 cyc/h, load factor: 0.5 conforming to IEC 60947-5-1 appendix C 1000000 Cycles, AC-15, 4 A at 24 V, operating rate <3600 cyc/h, load factor: 0.5 conforming to IEC 60947-5-1 appendix C 1000000 Cycles, DC-13, 0.2 A at 110 V, operating rate <3600 cyc/h, load factor: 0.5 conforming to IEC 60947-5-1 appendix C 1000000 cycles, DC-13, 0.5 A at 24 V, operating rate <3600 cyc/h, load factor: 0.5 conforming to IEC 60947-5-1 appendix C |
| Electrical reliability | $\Lambda < 10\exp(-6)$ at 5 V, 1 mA in clean environment conforming to IEC 60947-5-4 $\Lambda < 10\exp(-8)$ at 17 V, 5 mA in clean environment conforming to IEC 60947-5-4 |
| Device presentation | Complete product |

Environment

| | |
|---------------------------------------|--|
| Protective treatment | TH |
| Ambient air temperature for storage | -40...70 °C |
| Ambient air temperature for operation | -40...70 °C |
| Electrical shock protection class | Class II conforming to IEC 60536 |
| IP degree of protection | IP66 conforming to IEC 60529 IP67 |
| NEMA degree of protection | NEMA 13 NEMA 4X |
| IK degree of protection | IK04 conforming to IEC 50102 |
| Standards | IEC 60947-5-1 CSA C22.2 No 14 UL 508 IEC 60947-1 IEC 60947-5-4 JIS C8201-5-1 JIS C8201-1 |
| Product certifications | CSA UL LROS (Lloyds register of shipping) BV GL DNV |
| Vibration resistance | 5 gn (f= 2...500 Hz) conforming to IEC 60068-2-6 |
| Shock resistance | 30 gn (duration = 18 ms) for half sine wave acceleration conforming to IEC 60068-2-27 50 gn (duration = 11 ms) for half sine wave acceleration conforming to IEC 60068-2-27 |

Offer Sustainability

| | |
|----------------------------|---|
| REACH Regulation | REACH Declaration |
| EU RoHS Directive | Pro-active compliance (Product out of EU RoHS legal scope) EU RoHS Declaration |
| Mercury free | Yes |
| China RoHS Regulation | China RoHS Declaration |
| RoHS exemption information | Yes |
| WEEE | The product must be disposed on European Union markets following specific waste collection and never end up in rubbish bins |

Dimensions

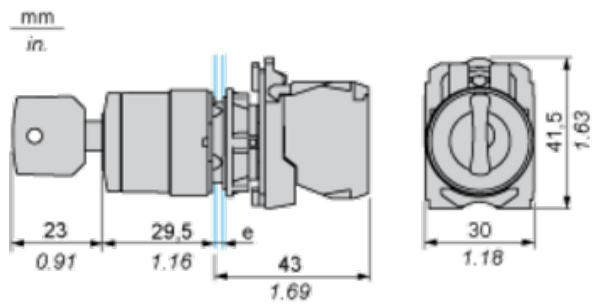

e: clamping thickness: 1 to 6 mm / 0.04 to 0.24 in.

Panel Cut-out for Pushbuttons, Switches and Pilot Lights (Finished Holes, Ready for Installation)

Connection by Screw Clamp Terminals or Plug-in Connectors or on Printed Circuit Board



- (1) Diameter on finished panel or support
- (2) For selector switches and Emergency stop buttons, use of an anti-rotation plate type ZB5AZ902 is recommended.
- (3) $\varnothing 22.5$ mm recommended ($\varnothing 22.3_0^{+0.4}$) / $\varnothing 0.89$ in. recommended ($\varnothing 0.88$ in. $_0^{+0.016}$)

| Connections | a in mm | a in in. | b in mm | b in in. |
|---|---------|----------|---------|----------|
| By screw clamp terminals or plug-in connector | 40 | 1.57 | 30 | 1.18 |
| By Faston connectors | 45 | 1.77 | 32 | 1.26 |
| On printed circuit board | 30 | 1.18 | 30 | 1.18 |

Detail of Lug Recess

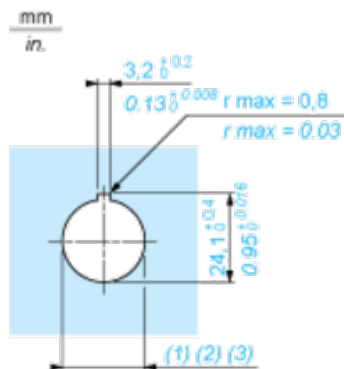

- (1) Diameter on finished panel or support
- (2) For selector switches and Emergency stop buttons, use of an anti-rotation plate type ZB5AZ902 is recommended.
- (3) $\varnothing 22.5$ mm recommended ($\varnothing 22.3_0^{+0.4}$) / $\varnothing 0.89$ in. recommended ($\varnothing 0.88$ in. $_0^{+0.016}$)