

Datasheet

RS PRO RS- H3A.P Heavy Duty Housing

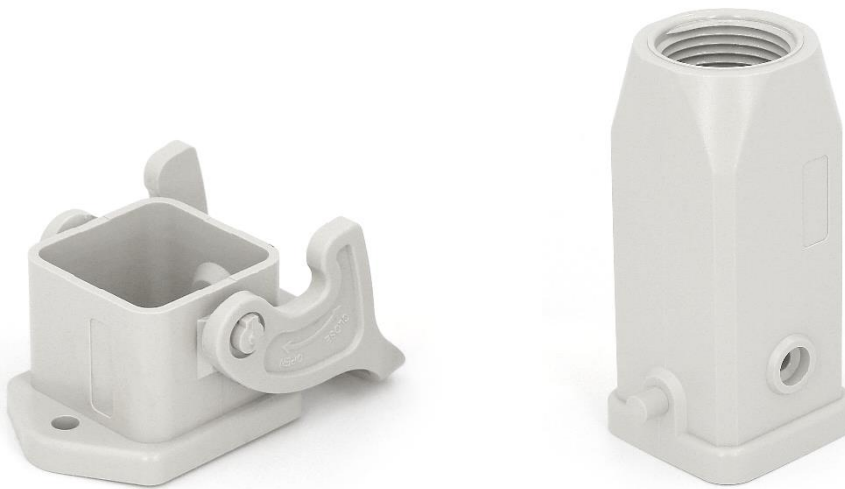

The RS PRO Heavy-Duty Connector series is a full range of heavy-duty inserts, housings, crimps and accessories. The housing is produced from corrosion resistant, powder coated, die cast Aluminium with locking levers made from galvanized Iron. These are available in standard or tall variations with both single and double locking options and offer IP65 protection. Created for applications that are subjected to harsh environments or where high vibration can cause standard connectors to fail makes these connectors ideal for food & beverage manufacturing, packaging machines, conveyor belt systems, railway, oil & gas processing and other industrial automation. The entire range of connectors are RoHS compliant and as with all RS PRO products, offer exceptional value for money.

Features & Benefits:

- Polycarbonate Housing
- IP65
- For use with PG or M style Cable Glands
- Fits RS PRO Heavy Duty Inserts

Quality Standards



Dimensional line drawings

H3A.P Plastic Bulkhead Mount 1 Locking Lever 208-4209

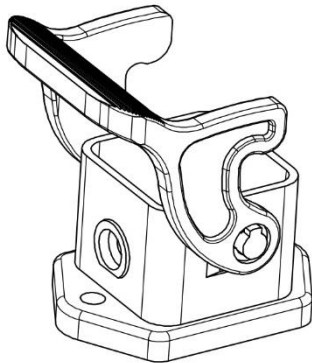
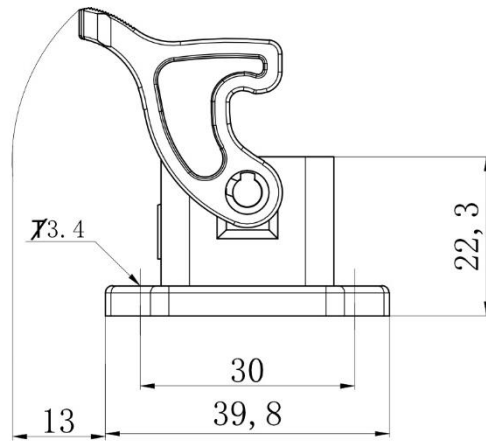
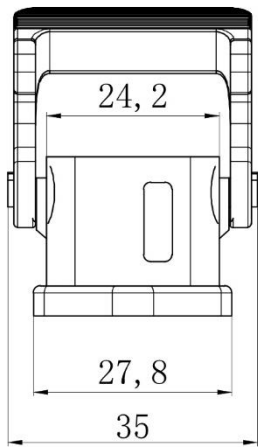

Dimensional line drawings

Plastic Bulkhead Mount Side Entry 1 Locking Lever 208-4210

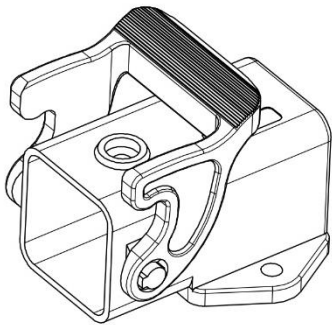
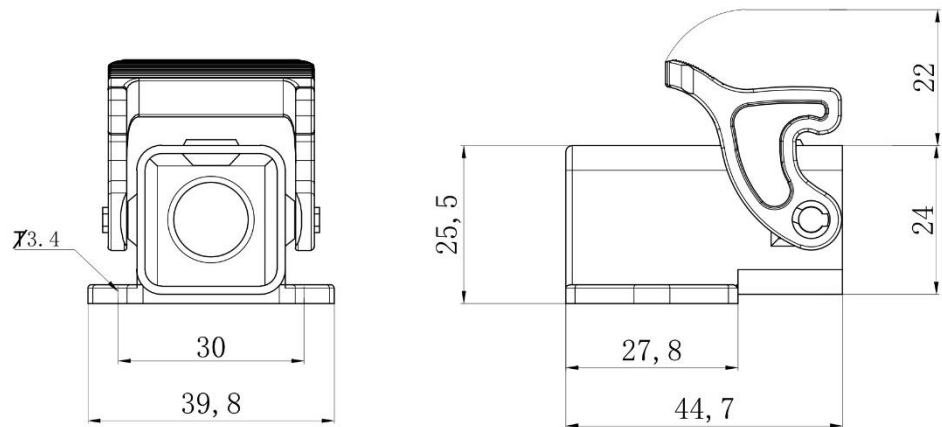

Dimensional line drawings

Plastic Cable to Cable 1 Locking Lever

M20 = 208-4211

PG11 = 208-4212

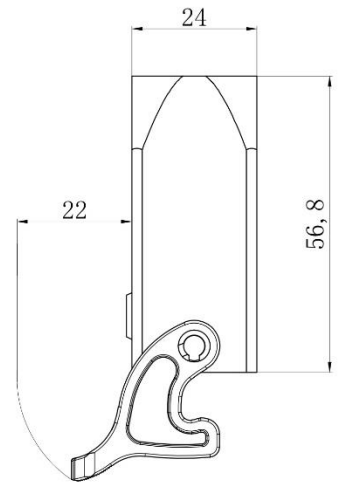
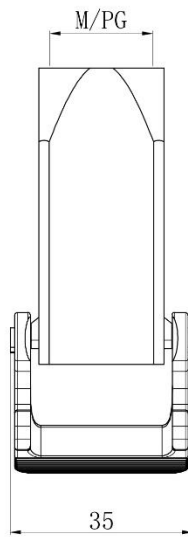
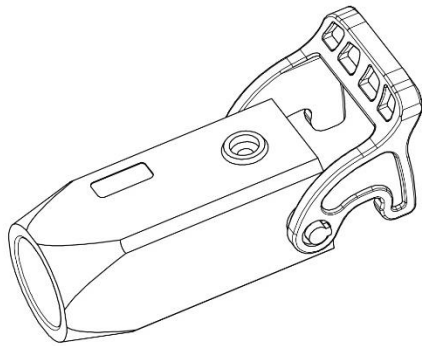

Dimensional line drawings

Plastic Side Entry Hood 2 Locking Points

M20 = 208-4213

PG11 = 208-4214

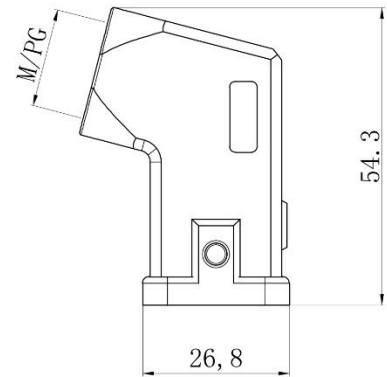
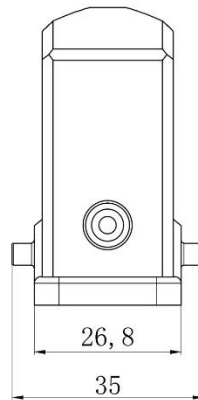
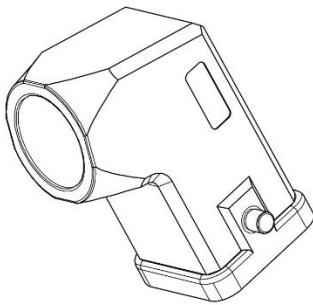

Dimensional line drawings

Plastic Surface Mount 1 Locking Lever

M20 = 208-4215

PG11 = 208-4216

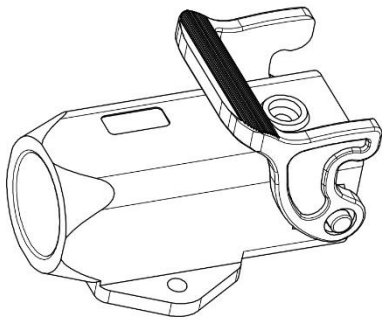
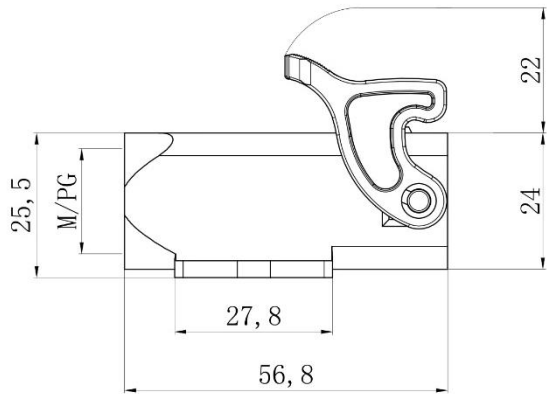
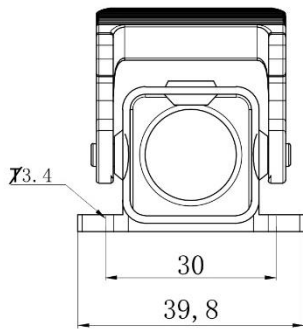

Dimensional line drawings

Plastic Top Entry Hood 2 Locking Points

M20 = 208-4217

PG11 = 208-4219

