

# Datasheet

## RS PRO Piezo Audio Indicator

EN



### A. SCOPE

This specification applies piezo audio indicator 1812657

### B. SPECIFICATION

No.	Item	Unit	Specification	Condition
1	Resonant frequency	KHz	4.0 ± 0.5	
2	Operating Volt. range	VDC	3~ 15	
3	Current consumption	mA	MAX 12	at 12VDC
4	Sound pressure level	dB	MIN 95	at 10cm/12VDC
5	Rated Voltage	VDC	12	
6	Tone		Continuous	
7	Operating temp.	°C	-40 ~ +85	
8	Storage temp.	°C	-40 ~ +90	
9	Dimension	mm	φ 22.0 x H7.0	See appearance drawing
10	Weight (MAX)	gram	2.8	
11	Material		PPS ( BLACK )	
12	Terminal		SMD type (Plating Sn)	See appearance drawing
13	Environmental Protection Regulation		RoHS2.0	
14	Storage life	month	6	6 months preservation at room temp.(25±3°C), Humidity40% .

### C. APPEARANCE DRAWING

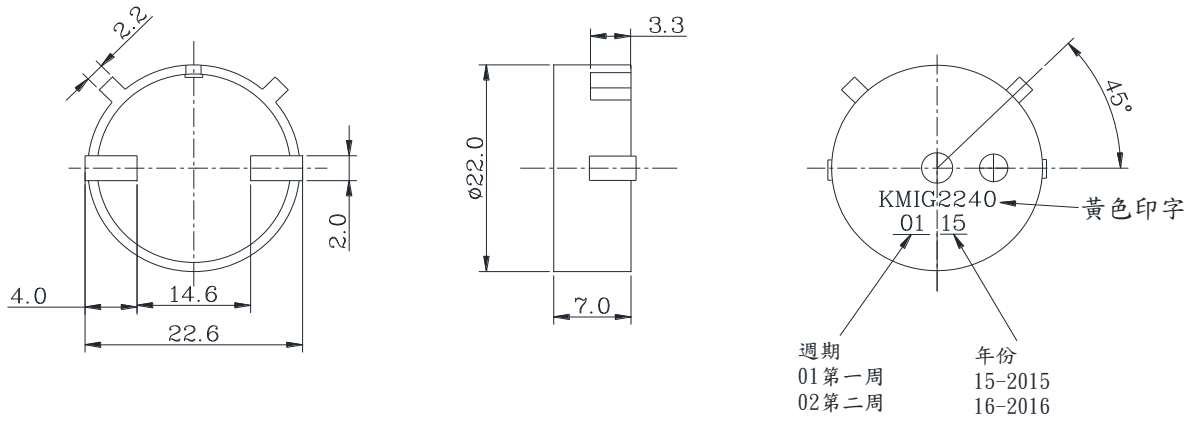

**Tol : ± 0.5 , Unit : mm**

### D. MEASURING METHOD

S.P.L. Measuring Circuit

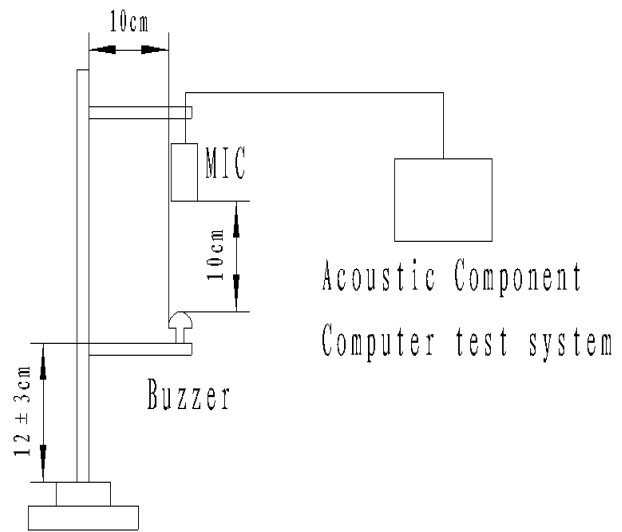
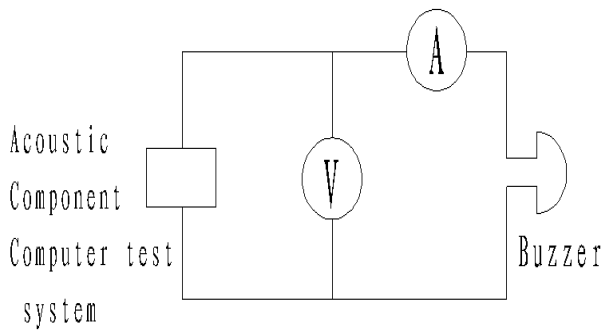

Mic : RION S.P.L meter UC30 or equivalent

Mic : RION UC30

## E.VOLTAGE:SOUND PRESSURE LEVEL / VOLTAGE: CURRENT CONSUMPTION CHARACTERISTICS

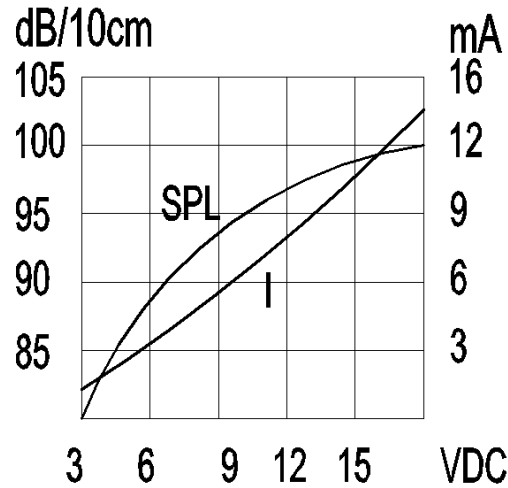

## F. MECHANICAL CHARACTERISTICS

No.	Item	Test Condition	Evaluation standard
1	Solderability	Lead terminals are immersed in rosin for 5 seconds and then immersed in solder bath of $+270\pm 5^{\circ}\text{C}$ for $3\pm 1$ seconds.	90% min. lead terminals shall be wet with solder. (Except the edge of terminal)
2	Soldering Heat Resistance	Lead terminal are immersed up to 1.5mm from sounder's body in solder bath of $+300\pm 5^{\circ}\text{C}$ for $3\pm 0.5$ seconds or $+260\pm 5^{\circ}\text{C}$ for $10\pm 1$ seconds.	No interference in operation .
3	Terminal Mechanical Strength	The force 10 seconds of 9.8N (1.0kg) is applied to each terminal in axial direction.	No damage and cutting off
4	Vibration	Buzzer shall be measured after being applied vibration of amplitude of 1.5mm with 10 to 55hz band of vibration frequency to each of 3 per-pendicular directions for 2 hours.	The value of oscillation frequency/ current consumption should be in 10% compared with initial ones .The SPL should be in $\pm 10\text{dB}$ compared with initial one.
5	Drop test	<b>The part only shall be dropped from a height of 70cm onto a 10mm thick wooden board 3 times in 3 axes (X.Y.Z). (a total of 9 times).</b>	

## G. ENVIRONMENT TEST

No.	Item	Test Condition	Evaluation standard
1	High temp. test	After being placed in a chamber at +90°C for 120 hours	Being placed for 4 hours at +25°C, buzzer shall be measured. The value of oscillation frequency/ current consumption should be in ±10% compared with initial ones. The SPL should be in ±10dB compared with initial one.
2	Low temp. test	After being placed in a chamber with -40°C for 120 hours	
3	Humidity test	After being placed in a chamber at +40°C ±2°C and 90~95% relative humidity for 120 hours	
4	Temp. cycle test	<p>The part shall be subjected to 5 cycles. One cycle shall be consist of :</p> <p>The diagram shows a temperature cycle test profile. It starts at -40±2°C for 0.5hr, rises to +40±5°C for 0.5hr, reaches a peak of +90±2°C for 0.25hr, falls back to +40±5°C for 0.5hr, and finally returns to -40±2°C for 0.25hr. The total duration of one cycle is 3 hours. This cycle is repeated 5 times.</p>	

## H. RELIABILITY TEST

No.	Item	Test condition	Evaluation
1	Operating life test	<p>1. Continuous life test 48 hours continuous operation at +70°C with rated voltage applied..</p> <p>2. Intermittent life test A duty cycle of 1 minute on, 1 minutes off, a minimum of 5000 times at room temp.( +25±2°C) and rated voltage applied.</p>	Being placed for 4 hours at +25°C, buzzer shall be measured. The value of oscillation frequency/ current consumption should be in ±10% compared with initial ones. The SPL should be in ±10dB compared with initial one.

### TEST CONDITION.

Standard Test Condition : a) Temperature : +5 ~ +35°C b) Humidity : 45-85%

c) Pressure : 860-1060mbar

Judgement Test Condition : a) Temperature : +25 ± 2°C b) Humidity : 60-70%

c) Pressure : 860-1060mbar

# I. Recommended Temperature Profile for Reflow Oven

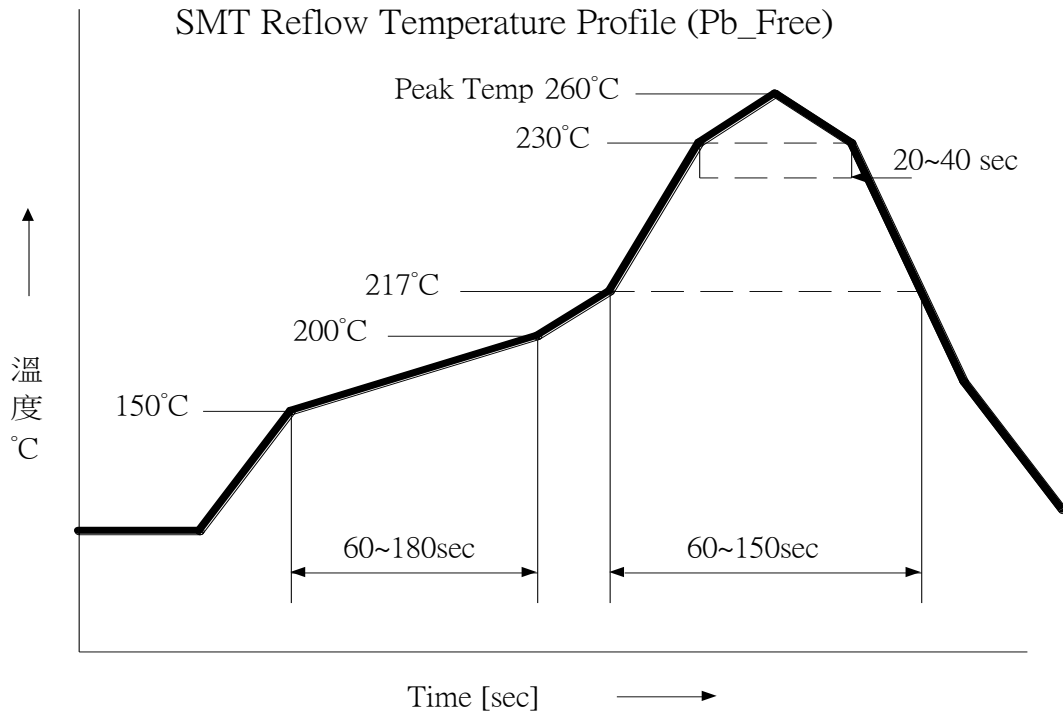

# J. Recommended land pattern

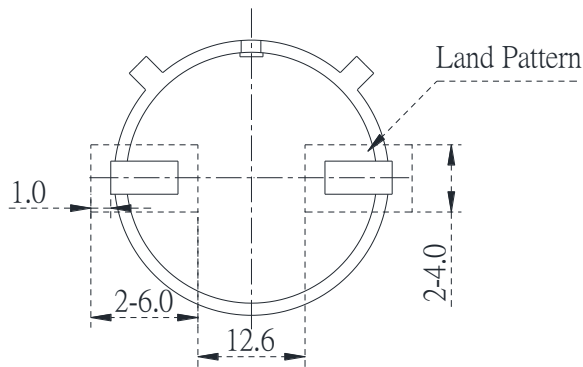

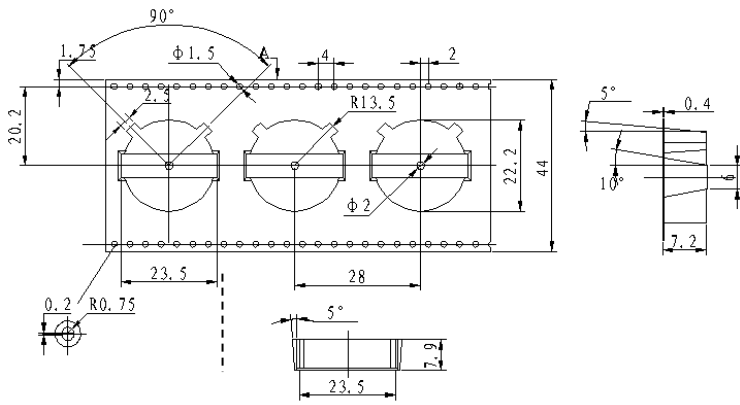

NOTE:

1. 10 sprocket hole pitch cumulative tolerance  $\pm 0.2$ mm.
2. All dimensions meet EIA-481-D requirements.
3. Thickness:  $0.4 \pm 0.05$ mm.
4. Component loaded per 13" reel: 300pcs.

