

## FEATURES

- 1 x Adjustable extension anvil
- 2 x Standard collars
- 2 x Setting rod support collars
- Supplied in fitted case with adjustment tools

# Mechanical Interchangeable Anvil Micrometer Tubular Frame DIN863

RS Stock No.: 2614512

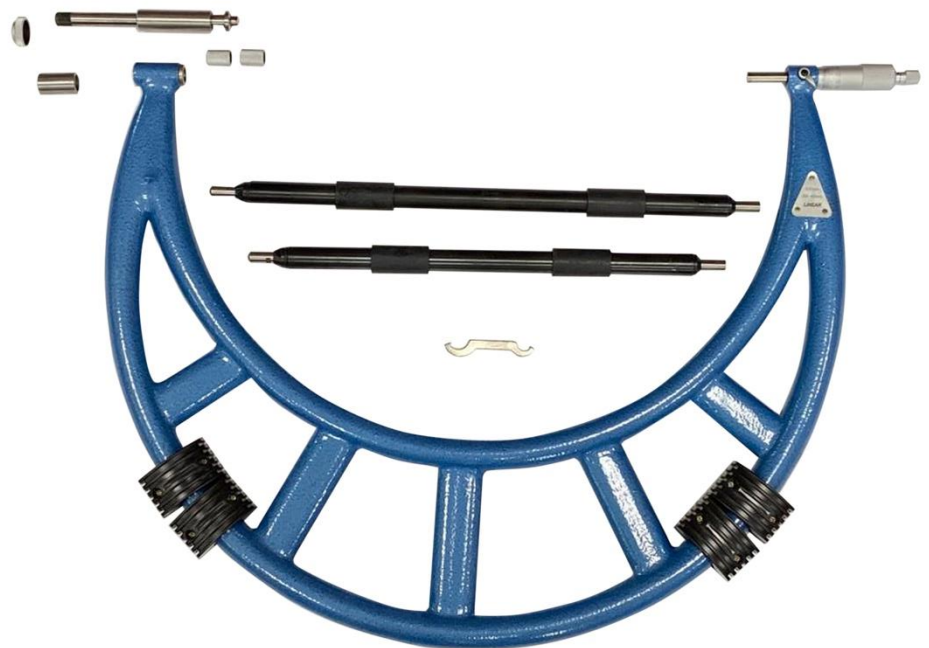

RS Professionally Approved Products bring to you professional quality parts across all product categories. Our product range has been tested by engineers and provides a comparable quality to the leading brands without paying a premium price.

## Product Description

- Micro fine graduations for accurate reading.
- Tungsten carbide measuring faces.
- Tubular frame.
- Spindle locking lever.
- Ratchet stop.
- Non-glare satin chrome barrel and sleeve.
- Blue baked enamel hammer tone finish.

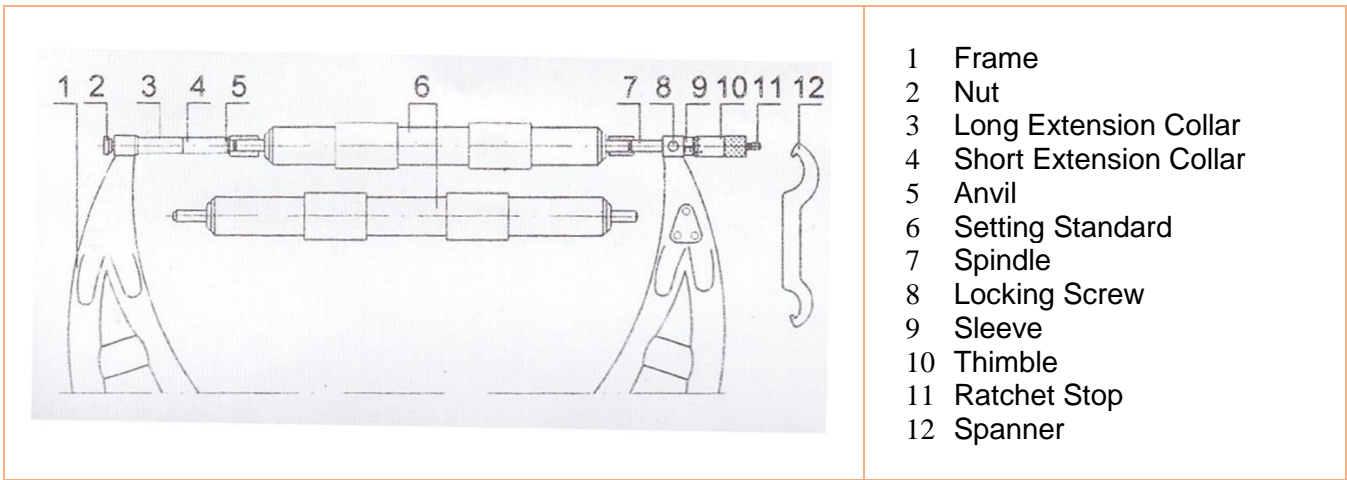

### Reading Example:

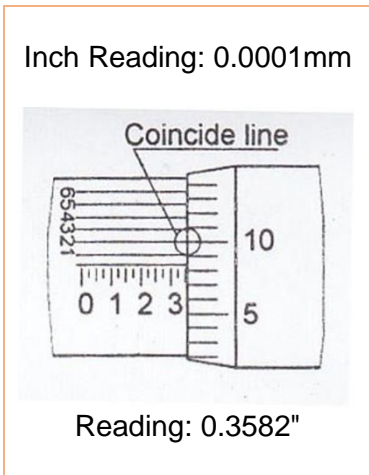

### Frame Deformation

Ensure that the Frame deformation is kept to a minimum by setting zero with the micrometer in the same position as it will be when taking measurements

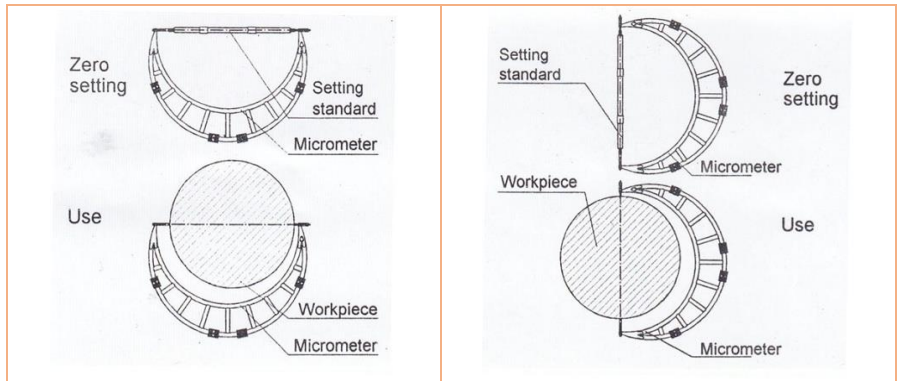

## Operating Instructions and Care

Check all new and in use micrometers for correct zero setting prior to use.

Clean micrometer spindle, extension anvil and collars with soft cloth or paper to remove any oil or particles which may affect the measurements.

Clean the extension anvil seat in the frame. Fit extension anvil and collars in place and clamp securely with knurled nut.

Ensure that the micrometer is thermally stabilised with the temperature where it is to be used.

Larger micrometers should be clamped in a suitable stand to make setting easier.

Ensure that the spindle lock is off.

Place a setting standard between the anvils using the support collars for safety and advance the spindle towards the setting rod. Use the ratchet stop to finally close the spindle onto the setting rod. Rotate the ratchet stop 1 ½ to 2 revolutions to exert a constant measuring force.

In the closed position the zero on the thimble should coincide with the horizontal line on the sleeve.

If the two lines do not coincide, small adjustments can be made by using the "C" spanner provided.

Insert the "C" spanner into the hole at the back of the sleeve and gently turn the sleeve in the direction required to achieve line up.

The micrometer is now set and ready for use.

Clean micrometers and check zero position regularly during use to ensure their continued accuracy.

After use always clean and replace the micrometer in its box.

### General Specifications

<b>Manufacturer's code</b>	2614512
<b>Range</b>	20"-24"
<b>Graduations</b>	0.001"
<b>Adjustable Extension</b>	1
<b>Setting Rods</b>	2
<b>Accuracy</b>	0.0006"

### Mechanical Specifications

--	--

### Electrical Specifications

--	--

### Protection Category

--	--

### Classification

eCl@ss (Version)	
UNSPSC (Version)	

### Approvals

Declarations	
Hazardous Area Certification	
Standards Met	

### Similar Products

Stock No.	Brand	Product Name	Attribute 1	Attribute 2	Attribute 3