

"A" OK FOR END INSERT MOLD MODIFICATION.
 "B" MUST BE A MACHINED MODIFICATION.

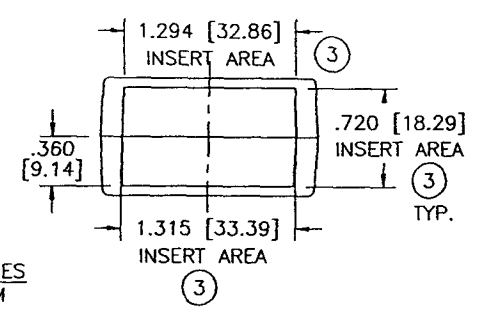

INCHES
MM

- 1. EXTERIOR INSERT AREA, FOR IN MOLD MODIFICATION.
- 2. INTERIOR INSERT AREA, FOR IN MOLD MODIFICATION.
- 3. END INSERT AREA, FOR IN MOLD MODIFICATION, TYP. BOTH SIDES AND BOTH ENDS.
- 4. P.C. CARD 1.40 [35.56] W X 2.20 [55.88] L X .062 [1.57] THK.

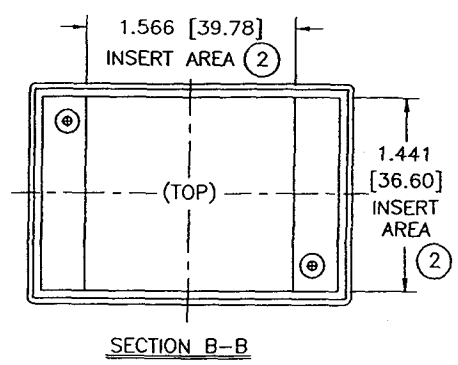
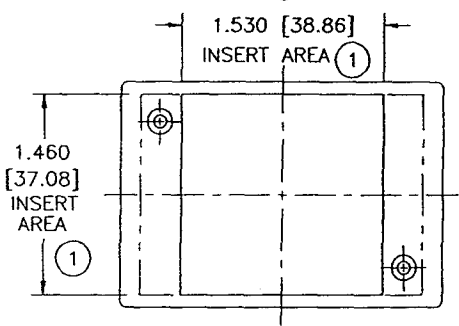
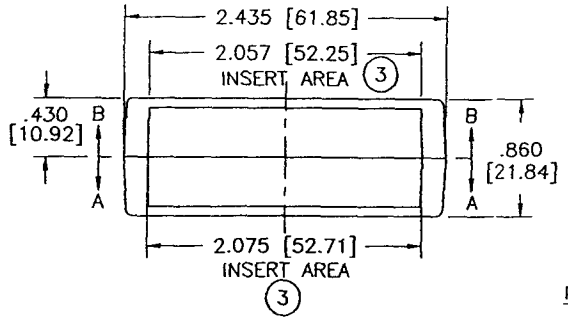
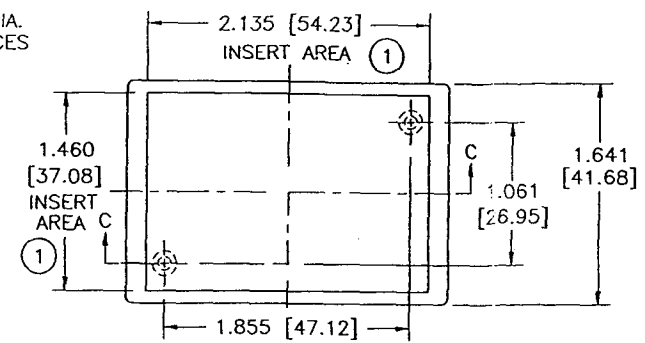
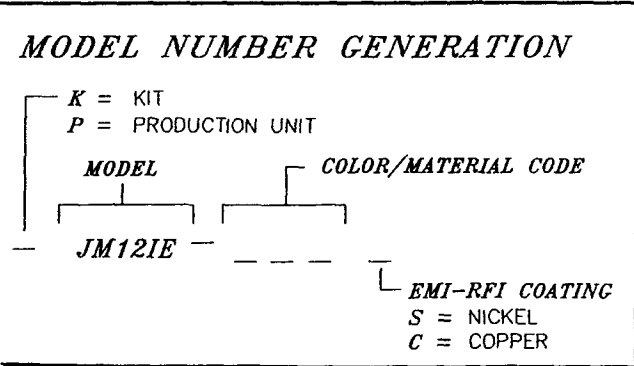
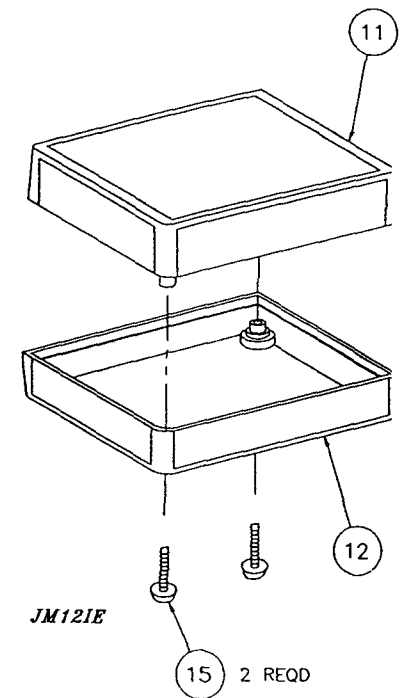

COLOR / MATERIAL CODE		
COLOR	94HB	94VO
BLACK	000	028
*GREY	001	024
*TAN	002	025
P.C.BONE	039	060

*SEE FACTORY FOR AVAILABILITY

ITEM	PART NUMBER	DESCRIPTION	QUANTITY	
			PROD	KIT
15	60228-08	SCREW, P.H. # 2X. .38LG	2	2
12	72258-01-XXX	BOTTOM COVER	1	1
11	72257-01-XXX	TOP COVER	1	1

