

MAX14919A Evaluation Kit

Evaluates: MAX14919A

General Description

The MAX14919A evaluation kit (EV kit) provides a proven design to evaluate the MAX14919A industrial-grade quad low-side switch with 140mΩ (typ) R_{ON} and $\pm 1\text{kV}/42\mu\text{s}$ surge protection.

The MAX14919A EV kit features an isolated power and signal interface to provide pin-level control of the four low-side switches in the MAX14919A. The EV kit also features reverse-current detection and status indication caused by miswiring faults at output and return terminals.

The EV kit comes with the MAX14919AATP+ (20 TQFN-EP, 4mm x 5mm footprint) device installed.

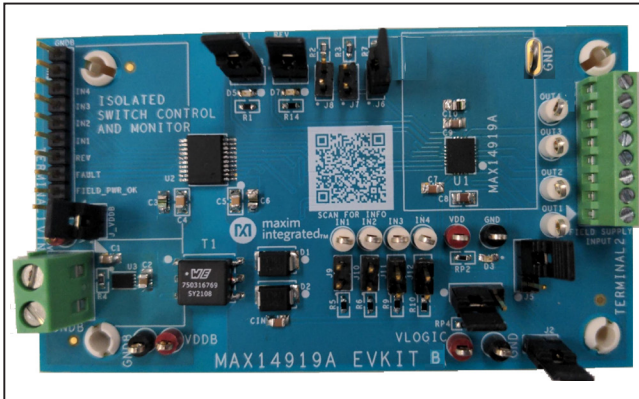

Features

- Robust Operation with a Wide Range of Input Voltages and Load Conditions
- Surge Protection with Up To $\pm 1\text{kV}$ IEC61000-4-5 at Optional Field Supply Input and Output to Ground
- LED Indication of Fault and Reverse-Current Detect Conditions
- Multiple Fault-Condition Indications
 - Reverse-Current Detection
 - Undervoltage Lockout on V5 Output
 - Short Detection on RCLIM Control Input
 - Thermal Shutdown Fault
- Inrush Current Control to Allow up to Two Times the Maximum Load Current
- Resistor-Selectable Options to Set Maximum Allowable Load Current
- +1.8V to +5.5V Wide Logic-Voltage Range
- +3V to +5.5V Isolated Supply Input Range
- Proven PCB Layout
- Fully Assembled and Tested

Ordering Information appears at end of data sheet.

Block Diagram

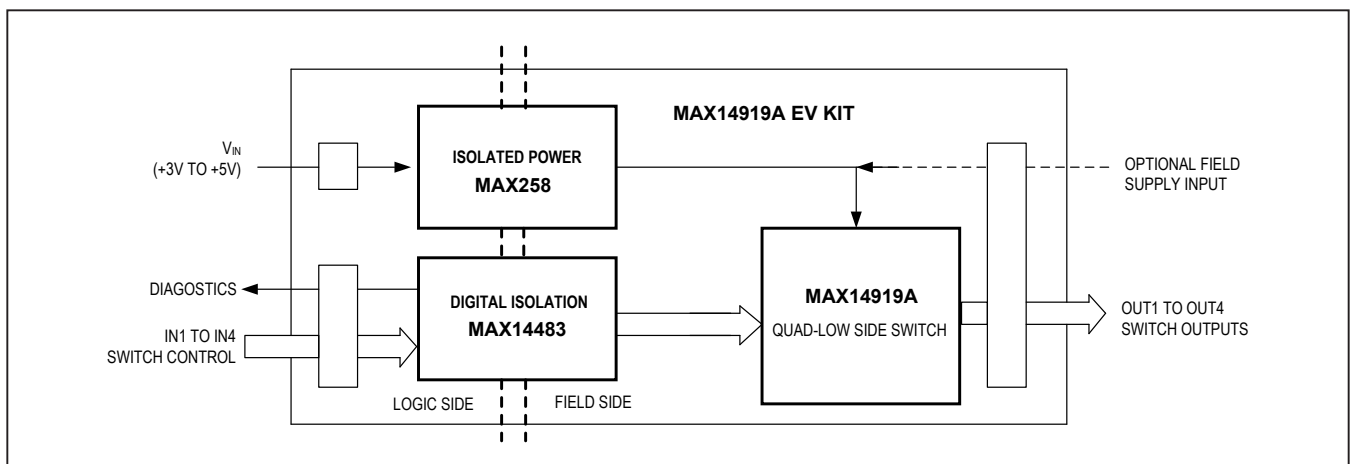

Quick Start

Required Equipment

- MAX14919A EV kit
- +5.5V DC power supply
- 1.8V to 5.5V DC power supply
- +24V DC power supply
- Signal generator
- Resistive load (10kΩ)
- Oscilloscope

Procedure

The EV kit is fully assembled and tested. Follow the steps to verify board operation:

See [Table 1](#) for Jumper Positions and Configurations.

See [Table 2](#) for Terminal Description.

- 1) Verify that all jumpers are in default positions ([Table 1](#)).
- 2) Connect the EV kit V_{IN} terminal Pin 1 and Pin 2 to the 5V output of external DC power. Connect the positive output of the power supply at Pin 1 and the negative/return terminal at Pin 2. Do not turn on the power supply.
- 3) Connect the EV kit Terminal 1, Pin1 to the positive terminal of a +1.8V external DC power supply. Connect the negative/return terminal of the power supply to Terminal 1, Pin 10. Do not turn on the power supply.
- 4) With the power supply output disabled, connect the positive terminal of the +24V power supply to one end

- of the 10kΩ resistive load. Connect the other end of the resistive load to OUT1 or Terminal 2, Pin 2 on the field side.
- 5) Connect the negative/return terminal of the +24V power supply to Terminal 2, Pin 8 of the EV kit.
- 6) Connect the positive output of the signal generator to ISO_IN1 or Terminal 1, Pin 5 of the logic side, and the return output of the signal generator wire to GNDB (Terminal 1, Pin 9 and Pin 10).
- 7) With the output disabled, set the signal generator output at 1kHz square wave with V_{HIGH} of 1.8V and V_{LOW} of 0V.
- 8) Connect a scope probe at OUT1 with respect to the COM signal.
- 9) Turn on the +5V and +1.8V power supplies and verify that the green LEDs D3 and D6 are illuminated, indicating that the V_{DD} and V_L supply inputs to MAX14919A are present. Turn on/enable the +24V power supply.
- 10) Turn on/enable the signal generator output, which is connected to ISO_IN1.
- 11) Using the scope, verify that the MAX14919A OUT1 switch is turned ON and is switching at 1kHz rate.
- 12) Disable the signal generator output and repeat steps 9 through 11 by connecting the control power supply to ISO_IN2 to ISO_IN4 to evaluate each channel.
- 13) Disable the signal generator and all power supplies, in that order, after evaluation.

Table 1. MAX14919A EV Kit Shunt Positions and Settings

HEADER	SHUNT POSITION	FUNCTION DESCRIPTION
J_VDDDB	Not Installed*	Separate power supply inputs must be provided at V_{DDB} input at Terminal 1, Pin 1 and V_{IN} terminal. This is useful when V_{DDB} and ISO_INx signals are lower than +3V, to allow a standard +1.8V interface signals from a microcontroller to be directly connected to the MAX14919A EV kit.
	1-2	Installing this jumper connects the V_{DDB} supply to V_{IN} . With a shunt installed, the EV kit can be powered from one common supply either at V_{IN} or Terminal 1, Pin 1. This supply must be between 3V and 5.5V.
J1	Not Installed*	The V_{DD} supply input of MAX14919A is not connected.
	1-2	Connects the V_{DD} supply input of MAX14919A to the unregulated isolated power supply output.
	2-3	Connects the V_{DD} supply input of MAX14919A to the field power supply connection from Terminal 2, Pin 1.

Table 1. MAX14919A EV Kit Shunt Positions and Settings (continued)

HEADER	SHUNT POSITION	FUNCTION DESCRIPTION
J2	1-2*	Connects the V ₅ regulator supply output to the V _L input of MAX14919A (logic supply input). The power supply rail V _{LOGIC} powers Side A of the MAX14483 digital isolator and 74HC08 AND gate.
	Not Installed	The V ₅ regulator output/logic supply is not connected to the logic supply input V _L of MAX14919A. An external source must be supplied through the V _{LOGIC} test point and GND. This option can be used to evaluate with different logic supply voltages from +1.8V to +5.5V.
J3	1-2*	Connects the FAULT logic output to the pullup resistor and red fault indication LED D5.
	Not Installed	Disconnects the pullup resistor. The FAULT indication function is not in use.
J4	1-2*	Connects the REV (reverse-current detection) logic output to the pullup resistor and red fault indication LED D7.
	Not Installed	Disconnects the pullup resistor. The REV indication function is not in use.
J5	1-2*	Enables INRUSH mode, allowing up to two times the maximum current limit for up to 10ms.
	2-3	Disables INRUSH mode.
J6	1-2*	Sets current limit for all channels to 600mA.
	Not Installed	Disconnects resistor R7.
J7	1-2	Sets current limit for all channels to 300mA.
	Not Installed*	Disconnects resistor R3.
J8	1-2	Sets current limit for all channels to 100mA.
	Not Installed*	Disconnects resistor R2.
J9	Not Installed*	Default condition using the isolated interface at Terminal 1. The output of the logical AND gate is connected to the IN1 input of MAX14919A. The signal controlling the IN1 switch is from ISO_IN1. See Table 3 .
	1-2	If the MAX14919A is evaluated without the isolated interface, resistor R8 must be removed and OUT1 is controlled by applying a signal to test point IN1. Installing a shunt across 1-2 pulls the IN1 input high. See the Evaluating Only the MAX14919A Device section.
J10	Not Installed*	Default condition using the isolated interface at Terminal 1. The output of the logical AND gate is connected to the IN2 input of MAX14919A. The signal controlling the IN2 switch is from ISO_IN2. See Table 3 .
	1-2	If MAX14919A is evaluated without the isolated interface, resistor R11 is removed and OUT2 is controlled by applying a signal to test point IN2. Installing a shunt across 1-2 pulls the IN2 input high. See the Evaluating Only the MAX14919A Device section.
J11	Not Installed*	Default condition using the isolated interface at Terminal 1. The output of the logical AND gate is connected to the IN3 input of MAX14919A. The signal controlling the IN3 switch is from ISO_IN3. See Table 3 .
	1-2	If MAX14919A is evaluated without the isolated interface, resistor R13 is removed and OUT3 is controlled by applying a signal to the test point IN3. Installing a shunt across 1-2 pulls the IN3 input high. See the Evaluating Only the MAX14919A Device section.
J12	Not Installed*	Default condition using the isolated interface at Terminal 1. The output of the logical AND gate is connected to the IN4 input of MAX14919A. The signal controlling the IN4 switch is from ISO_IN4. See Table 3 .
	1-2	If MAX14919A is evaluated without the isolated interface, resistor R12 is removed and OUT4 is controlled by applying a signal to the test point IN4. Installing a shunt across 1-2 pulls the IN4 input high. See the Evaluating Only the MAX14919A Device section.

*Default position.

Table 2. MAX14919A EV Kit Terminal Description

TERMINAL	POSITION	NAME	FUNCTION DESCRIPTION
VIN	1	Isolated Power Input	Positive supply input for isolated power, +3V to +5V.
	2	Isolated Power GND/Return	Negative/return of the supply for isolated power.
TERMINAL 1	1	V _{DDB}	V _{DDB} : The V _{DDB} supply input connected to MAX14483 for signal isolation.
	2	FIELD_PWR_OK	FIELD_PWR_OK: Output from Digital Isolator. Default high, indicating power good signal from the field side. When the field side is not present, the signal goes low, indicating a fault. This signal is driven from MAX14919A from the field side.
	3	ISO_FAULT	ISO_FAULT: Isolated fault-detect logic-side output for user control/monitor. Signal driven from the field side in the presence of a fault condition. (Jumper J3 is installed) See Table 3 .
	4	ISO_REV	ISO_REV: Isolated reverse-current-detect logic output for user control/monitor. Signal driven from the field side in the presence of a reverse-load connection. (Jumper J4 is installed). See Table 3 .
	5	ISO_IN1	ISO_IN1: Input to digital isolator. Input logic side to control MAX14919A IN1 switch input (field side). See Table 3 .
	6	ISO_IN2	ISO_IN2: Input to digital isolator. Input logic side to control MAX14919A IN2 switch input (field side).
	7	ISO_IN3	ISO_IN3: Input to digital isolator. Input logic side to control MAX14919A IN3 switch input (field side).
	8	ISO_IN4	ISO_IN4: Input to digital isolator. Input logic side to control MAX14919A IN4 switch input (field side).
	9, 10	GNDB	Ground/return signals for V _{DDB} supply.
TERMINAL 2	1	+24V_FIELD_SUPPLY_	FIELD_SUPPLY_INPUT: When MAX14919A chosen to power from field supply input, Jumper J1 is installed across 2-3 to connect this input to VDD of MAX14919A.
	2	OUT1	OUT1: Output of low-side switch channel 1. This terminal is connected to the load.
	3	OUT2	OUT2: Output of low-side switch channel 2. This terminal is connected to the load.
	4	OUT3	OUT3: Output of low-side switch channel 3. This terminal is connected to the load.
	5	OUT4	OUT4: Output of low-side switch channel 4. This terminal is connected to the load.
	6, 7, 8	COM	Load return signal. This signal must be lower than load potential.

Detailed Description of Hardware

The MAX14919A EV kit provides an easy-to-use and flexible solution for evaluating the MAX14919A, a quad low-side switch for industrial applications. The EV kit comes with a field-side terminal to enable the connection of loads to evaluate the device and the system.

The EV kit comes with surge protection of up to $\pm 1.2\text{kV}/42\Omega$ at optional field supply input and load output to ground.

Isolated Analog and Logic Supply

Terminal VIN allows a +3V to +5V supply input to power the MAX14919A using a MAX258 transformer driver and transformer T1 to provide isolated power. The output of the MAX258 transformer driver is an unregulated supply that feeds supply input to VDD of MAX14919A through Jumper J1. If the MAX14919A is powered from the isolated side (VIN), install Jumper J1 across 1-2. If the MAX14919A is powered from the field supply (+24V field supply), install Jumper J1 across 2-3.

Install Jumper J_VDDDB when interfacing to systems with +3.3V or +5V levels. Installing Jumper J_VDDDB connects VIN to VDDDB (power supply input) to U2 (MAX14483). Alternatively, if the user wishes to interface with a +1.8V system, leave jumper shunt at J_VDDDB uninstalled and use a separate supply input at VIN from +3V to +5V. Power the VDDDB supply input of U2 with +1.8V.

MAX14919A Switch Control

MAX14919A switch inputs IN1 to IN4 are controlled through the switch controller inputs Terminal (1) input Pin 5 to Pin 8. These signals are isolated using the MAX14483 device before being sent to the MAX14919A. Each MAX14919A low-side switch input can be controlled using the individual control pin ISO_IN1 to ISO_IN4. [Table 3](#) shows the truth table of switch output states.

Power Good Signal

When both the logic side (Side B) and isolated field side (Side A) are powered and the system is in normal operation, FIELD_PWR_OK signal is high. If the logic side is powered with no power applied to the VDD supply input of MAX14919A, the FIELD_PWR_OK signal goes low, indicating that no power is applied to MAX14919A. This function is enabled by MAX14483 which monitors the power level of both sides (SAA, SBA), indicating a logic-low level signal for no power present or logic-high for power present.

Connecting the Load to MAX14919A Switch Outputs

Terminal 2, Pin 2 through Pin 5 (field side) are the switch outputs (OUT1–OUT4) for connecting the appropriate loads. The COM inputs in Terminal 2, Pin 6 through Pin 8 are the power returns from the loads to MAX14919A EV kit.

No Power Applied on Logic Side

If the logic side (B side) loses power or if power is not applied to the VDDB of the MAX14483 isolator when the MAX14919A is powered, the SBA logic output of MAX14483 goes low, pulling the outputs of all the quad two-input AND gates low. This pulls all four inputs of MAX14919A low, making sure the switch outputs are OFF. Regardless of the levels present in subsequent input IN[1:4], the outputs are pulled low to ensure a fail-safe mechanism of maintaining a link with the logic side and preventing unwanted triggering of switch outputs. When the VDDA and VDDDB power inputs of MAX14483 are available, inputs at Terminal 1, Pin 5 through Pin 8 (ISO_IN1 to ISO_IN4) are driven to IN1 through IN4 of MAX14919A.

Evaluating Only the MAX14919A Device

If the MAX14919A device is to be evaluated without the isolated power and signal devices, removing the 0Ω shunts R8, R11, R12, and R13 after the logical AND gates (U4) ensures the isolator is disconnected from the MAX14919A device. Switch-control inputs IN[1:4] can be used to set individual channels to logic high by installing jumper shunts J9 to J12 to turn the switch on. MAX14919A device inputs IN1 through IN4 have weak internal pull-downs, and removing the jumper shunts J9 through J12 pulls the corresponding individual switch input IN[1:4] low to turn the intended channel off.

Table 3. MAX14922 Switch Control Truth Table

TERMINAL 1 CONTROL INPUT	LOGIC LEVEL	ASSOCIATED MAX14919A INPUT	OUTPUT STATUS
ISO_IN1	0	IN1	OFF
	1		ON
ISO_IN2	0	IN2	OFF
	1		ON
ISO_IN3	0	IN3	OFF
	1		ON
ISO_IN4	0	IN4	OFF
	1		ON

Using External Field Supply to Power MAX14919A

If the load and the MAX14919A share the same field supply, the MAX14919A is powered from the field supply and not through isolated power. Using power input at Terminal 2, Pin 1 as the supply input and installing a shunt across positions 2-3 on Jumper 1 selects the field supply input.

Diagnostic Features

The MAX14919A EV kit features on-board diagnostics to monitor faults. Jumpers J3 and J4 allow the user to view the diagnostic outputs through red status LEDs. Alternatively, test points are provided for each diagnostic output for probe (measurement). When the status LEDs are not required, removing the jumper disables the LEDs from the diagnostic output.

[Table 4](#) shows the features of the diagnostic outputs.

Current Limit Setting

Use jumpers J6, J7, and J8 to set the maximum allowable current through each switch output. Load current limit setting can be done from a minimum of 100mA to a maximum of 600mA. Jumper J6 selects a 25kΩ resistor, setting 600mA as the current limit. Jumper J7 selects a 49.9kΩ resistor, setting 300mA as the current limit. Jumper 8 selects a 124kΩ resistor, setting 120mA as the current limit.

Selectable Inrush mode

Installing a shunt across 1-2 on Jumper J5 pulls the inrush input high, enabling inrush mode on all channels. During inrush mode, each of the switches can handle twice the set limiting current for up to 10ms. Installing a shunt across 2-3 pulls inrush input low, disabling the feature.

Table 4. MAX14922 EV kit Diagnostic Output Features

DIAGNOSTIC FEATURE	JUMPER	TEST POINT	FUNCTION DESCRIPTION
Fault	J3	FAULT	Active-low fault. Fault is asserted low under any of the following conditions: <ul style="list-style-type: none"> Any of the switch outputs is in thermal overload Overtemperature shutdown Short detected on RCLIM input UVLO on V₅ (undervoltage lockout) Reverse current detected at load
Reverse Current Detect	J4	REV	Active-Low Output. REV status output goes low when reverse load current is detected.

Ordering Information

PART	TYPE
MAX14919AEVKIT#	EV KIT

#Denotes a RoHS-compliant part.

MAX14919A EV Kit Bill of Materials

ITEM	REF_DES	DNI/DNP	QTY	MFG PART #	MANUFACTURER	VALUE	DESCRIPTION	COMMENTS
1	C1	-	1	GRM21BR71C105KA01; GCM219R71C105KA37	MURATA;MURATA	1UF	CAP; SMT (0805); 1UF; 10%; 16V; X7R; CERAMIC	
2	C2	-	1	CL21B106KOQNNN; GRM21BZ71C106KE15; GMC21X7R106K16NT	SAMSUNG;MURATA,CAL-CHIP	10UF	CAP; SMT (0805); 10UF; 10%; 16V; X7R; CERAMIC	
3	C3, C6, C10, C16	-	4	ECP-U1C104MA5	PANASONIC	0.1UF	CAP; SMT (0805); 0.1UF; 20%; 16V; FILM CAPACITOR	
4	C4, C5, C15	-	3	GRM21BR72E103KW03; C0805C103KARAC; C2012X7R2E103K125AA	MURATA;KEMET;TDK	0.01UF	CAP; SMT (0805); 0.01UF; 10%; 250V; X7R; CERAMIC	
5	C7, CIN	-	2	GRM21BR71H105KA12; CL21B105KBFNNN; C2012X7R1H105K085AC; UMK212B7105KG	MURATA;SAMSUNG ELECTRONICS;TDK;TAIYO YUDEN	1UF	CAP; SMT (0805); 1UF; 10%; 50V; X7R; CERAMIC	
6	C8	-	1	C2012X7S2A105K125AB; GRJ21BC72A105KE11; GRM21BC72A105KE01	TDK;MURATA;MURATA	1UF	CAP; SMT (0805); 1UF; 10%; 100V; X7S; CERAMIC	
7	C9	-	1	C0805C103F1GAC	KEMET	0.01UF	CAP; SMT (0805); 0.01UF; 1%; 100V; C0G; CERAMIC	
8	D1, D2	-	2	MBRS230LT3G	ON SEMICONDUCTOR	MBRS230LT3G	DIODE; SCH; SMB (DO-214AA); PIV=30V; IF=2A	
9	D3, D6	-	2	APT1608CGCK	KINGBRIGHT	APT1608CGCK	DIODE; LED; STANDARD; GREEN; SMT (0603); PIV=2.1V; IF=0.02A; -40 DEGC TO +85 DEGC	GREEN
10	D5, D7	-	2	APT1608LSECK/J3-PRV	KINGBRIGHT	APT1608LSECK/J3-PRV	DIODE; LED; HYPER RED WATER CLEAR; RED; SMT (0603); VF=1.8V; IF=0.002A	RED
11	D8	-	1	MBRA210LT3G	ON SEMICONDUCTOR	MBRA210LT3G	DIODE; SCH; SMA (DO-214AC); PIV=10V; IF=2A	
12	D9	-	1	BAS16HT3G	ON SEMICONDUCTOR	BAS16HT3G	DIODE; SWT; SOD-323; PIV=200V; IF=0.2A	
13	D10	-	1	SMAJ33CA	VISHAY GENERAL SEMICONDUCTOR	33V	DIODE; TVS; SMA (DO-214AC); VRM=33V; IPP=7.5A	
14	FAULT, IN1-IN4, OUT1-OUT4, REV	-	10	5007	KEystone	N/A	TEST POINT; PIN DIA=0.125IN; TOTAL LENGTH=0.35IN; BOARD HOLE=0.063IN; WHITE; PHOSPHOR BRONZE WIRE SILVER PLATE FINISH;	
15	GND3, GND6, GNDB	-	3	5006	KEystone	N/A	TEST POINT; PIN DIA=0.125IN; TOTAL LENGTH=0.35IN; BOARD HOLE=0.063IN; BLACK; PHOSPHOR BRONZE WIRE SILVER PLATE FINISH;	
16	J1, J5	-	2	PCC03SAAN	SULLINS	PCC03SAAN	CONNECTOR; MALE; THROUGH HOLE; BREAKAWAY; STRAIGHT THROUGH; 3PINS; -65 DEGC TO +125 DEGC	
17	J2-J4, J6-J12, J_VDDB	-	11	PCC02SAAN	SULLINS	PCC02SAAN	CONNECTOR; MALE; THROUGH HOLE; BREAKAWAY; STRAIGHT THROUGH; 2PINS; -65 DEGC TO +125 DEGC	
18	MH1-MH4	-	4	9032	KEystone	9032	MACHINE FABRICATED; ROUND-THRU HOLE SPACER; NO THREAD; M3.5; 5/8IN; NYLON	
19	R1, R14	-	2	CRCW06035K60FK	VISHAY DALE	5.6K	RES; SMT (0603); 5.6K; 1%; +/-100PPM/DEGC; 0.1000W	
20	R2	-	1	CRCW0603124KFK	VISHAY DALE	124K	RES; SMT (0603); 124K; 1%; +/-100PPM/DEGC; 0.1000W	
21	R3	-	1	CRCW060349K9FK; ERJ-3EKF4992	VISHAY DALE;PANASONIC	49.9K	RES; SMT (0603); 49.9K; 1%; +/-100PPM/DEGC; 0.1000W	
22	R4, R8, R11-R13	-	5	RC1608J000CS; CR0603-JJ-000ELF; RC0603JR-070RL	SAMSUNG ELECTRONICS; BOURNS;YAGEO PH	0	RES; SMT (0603); 0; 5%; JUMPER; 0.1000W	
23	R5, R6, R9, R10	-	4	CRCW060310K0FK; ERJ-3EKF1002; AC0603FR-0710KL; RMCF0603FT10K0	VISHAY DALE;PANASONIC; YAGEO	10K	RES; SMT (0603); 10K; 1%; +/-100PPM/DEGC; 0.1000W	

MAX14919A EV Kit Bill of Materials (continued)

ITEM	REF_DES	DNI/DNP	QTY	MFG PART #	MANUFACTURER	VALUE	DESCRIPTION	COMMENTS
24	R7	-	1	PNM0603E2502BS	VISHAY DALE	25K	RES; SMT (0603); 25K; 0.10%; +/-25PPM/DEGC; 0.1500W	
25	R15-R18	-	4	CRCW0603100KFK; RC0603FR-07100KL; RC0603FR-13100KL; ERJ-3EKF1003; AC0603FR-07100KL	VISHAY DALE;YAGEO; YAGEO;PANASONIC	100K	RES; SMT (0603); 100K; 1%; +/-100PPM/DEGC; 0.1000W	
26	RP2, RP5	-	2	MCR03EZPF2002; ERJ-3EKF2002; CR0603-FX-2002ELF; CRCW060320K0FK	ROHM;PANASONIC; BOURNS;VISHAY DALE	20K	RES; SMT (0603); 20K; 1%; +/-100PPM/DEGC; 0.1000W	
27	RP4	-	1	RCW06033K30FK; RC0603FR-073K3L; RK73H1J3301F	VISHAY;YAGEO;VISHAY	3.3K	RES; SMT (0603); 3.3K; 1%; +/-100PPM/DEGC; 0.1000W	
28	SU2, SU4, SU5, SU7-SU9, SU12	-	7	NPC02SXON-RC	SULLINS ELECTRONICS CORP.	NPC02SXON-RC	CONNECTOR; FEMALE; MINI SHUNT; 0.100IN CC; OPEN TOP; JUMPER; STRAIGHT; 2PINS	
29	T1	-	1	750316769	WURTH ELECTRONICS INC	750316769	TRANSFORMER; SMT; 3.45:1 ;	
30	TERMINAL1	-	1	TSW-110-07-G-S	SAMTEC	TSW-110-07-G-S	CONNECTOR; MALE; THROUGH HOLE; 0.025 IN SQ POST HEADER; STRAIGHT; 10PINS	
31	TERMINAL2	-	1	OSTVN08A150	ON-SHORE TECHNOLOGY INC.	OSTVN08A150	CONNECTOR; FEMALE; THROUGH HOLE; SCREW TYPE; GREEN TERMINAL BLOCK; RIGHT ANGLE; 8PINS	
32	U1	-	1	MAX14919AATP+	MAXIM	MAX14919A	EVKIT PART - IC; PACKAGE CODE: T2045+1C; PACKAGE OUTLINE: 21-0726; LAND PATTERN: 90-100091; TQFN20-EP	
33	U2	-	1	MAX14483AAP+	MAXIM	MAX14483AAP+	IC; DISO; 6-CHANNEL; LOW-POWER; 3.75KV RMS SPI DIGITAL ISOLATOR; SSOP20	
34	U3	-	1	MAX258ATA+	MAXIM	MAX258ATA+	IC; DRV; 0.5A; PUSH-PULL TRANSFORMER DRIVER FOR ISOLATED POWER SUPPLY; TDFN8-EP 2X3	
35	U4	-	1	74HC08D	NXP	74HC08D	IC; AND; QUAD 2-INPUT AND GATE; NSOIC14	
36	VDD, VDDb, VIN1, VLOGIC1	-	4	5005	KEYSTONE	N/A	TEST POINT; PIN DIA=0.125IN; TOTAL LENGTH=0.35IN; BOARD HOLE=0.063IN; RED; PHOSPHOR BRONZE WIRE SILVER PLATE FINISH;	
37	VIN	-	1	1729018	PHOENIX CONTACT	1729018	CONNECTOR; FEMALE; THROUGH HOLE; GREEN TERMINAL BLOCK; RIGHT ANGLE; 2PINS	
38	PCB	-	1	MAX14919A	MAXIM	PCB	PCB:MAX14919A	-
TOTAL			93					

MAX14919A EV Kit Schematic Diagram

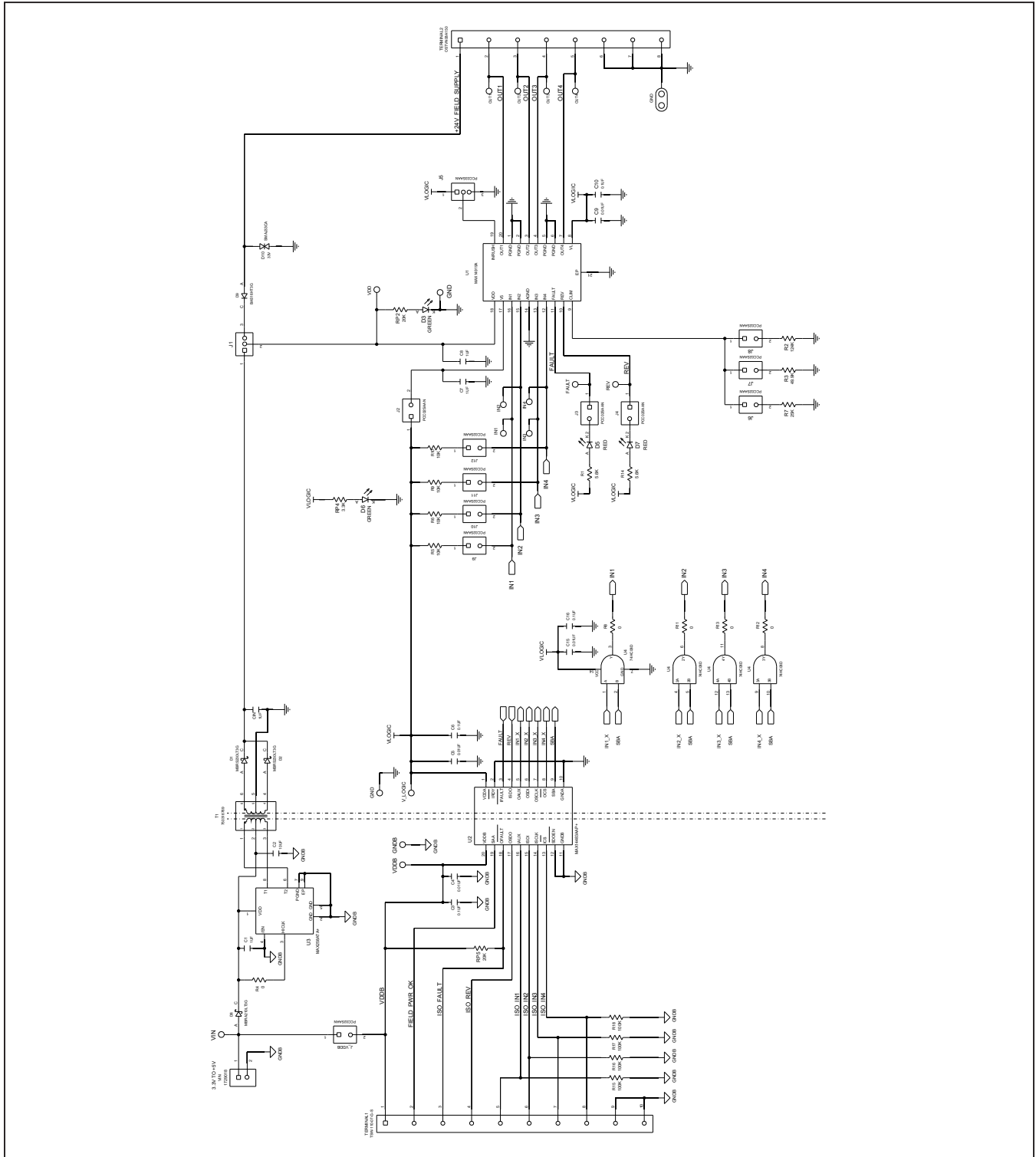

MAX14919A EV Kit PCB Layout

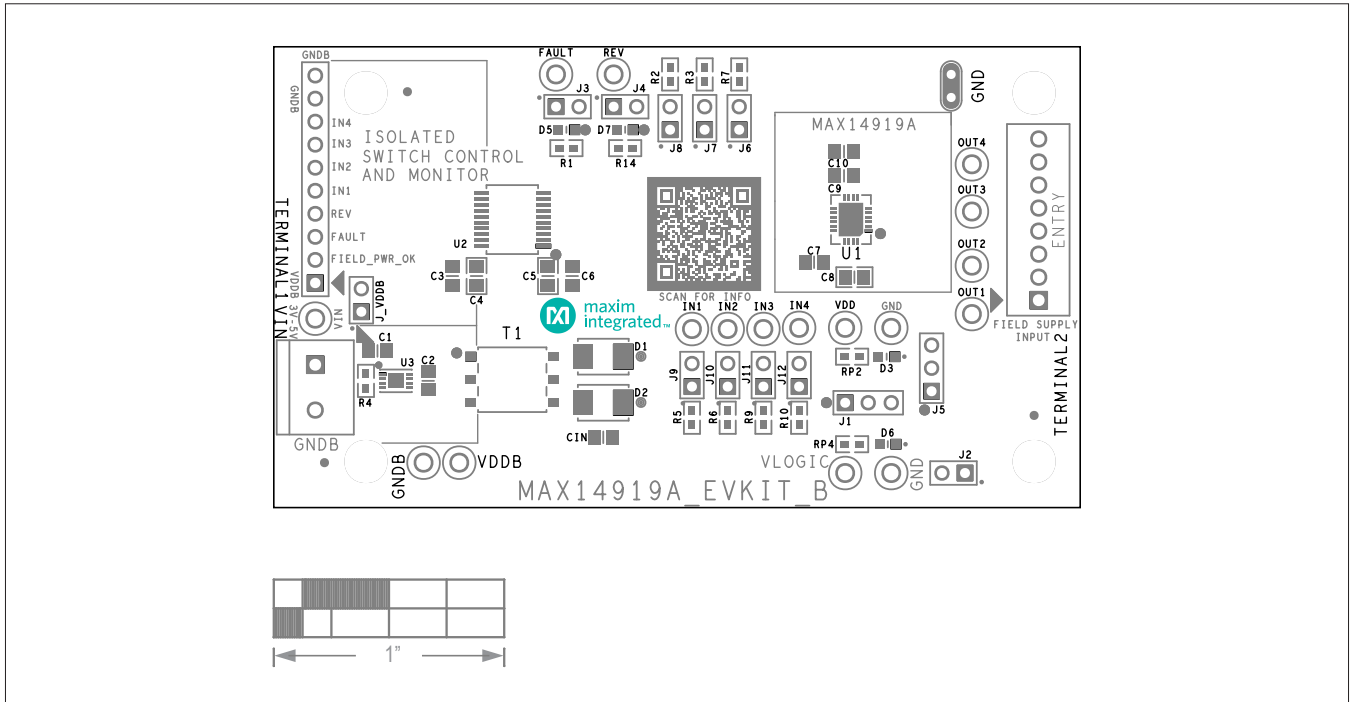

MAX14919A EV Kit PCB Layout—Top Silkscreen

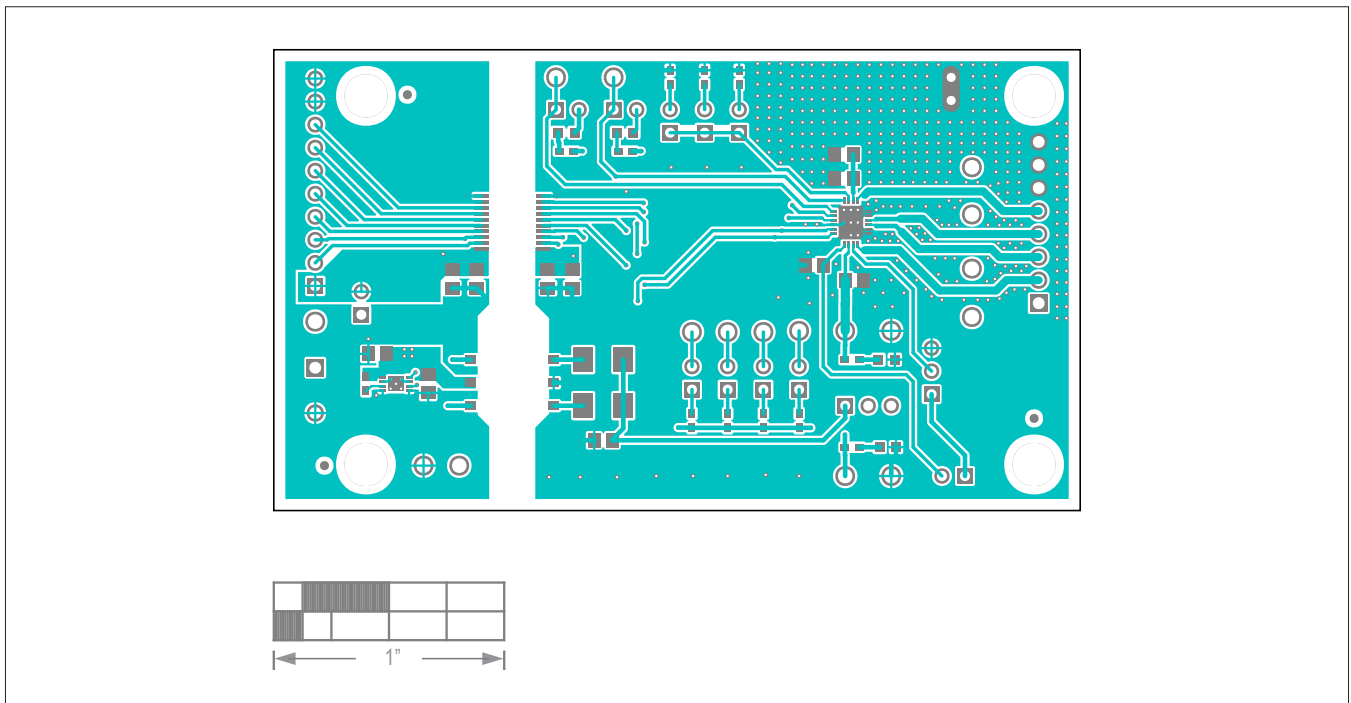

MAX14919A EV Kit PCB Layout—Top View

MAX14919A EV Kit PCB Layout (continued)

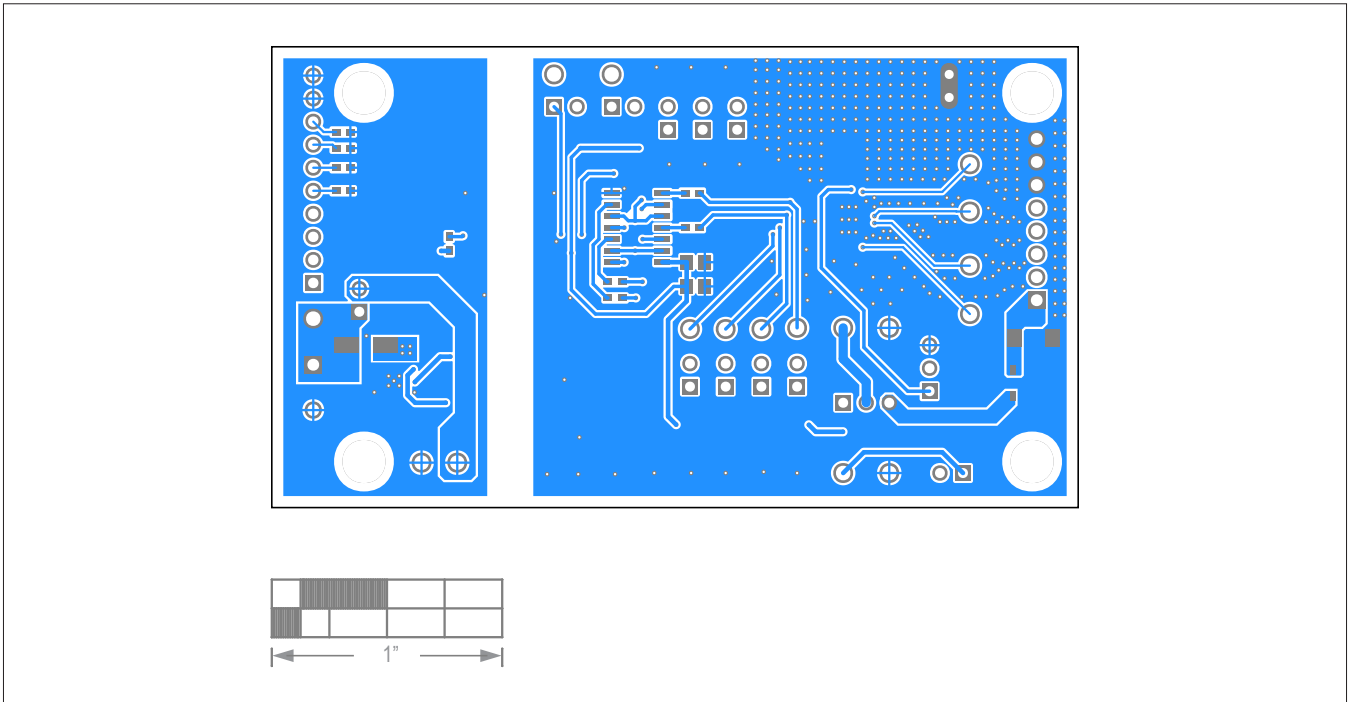

MAX14919A EV Kit PCB Layout—Bottom View

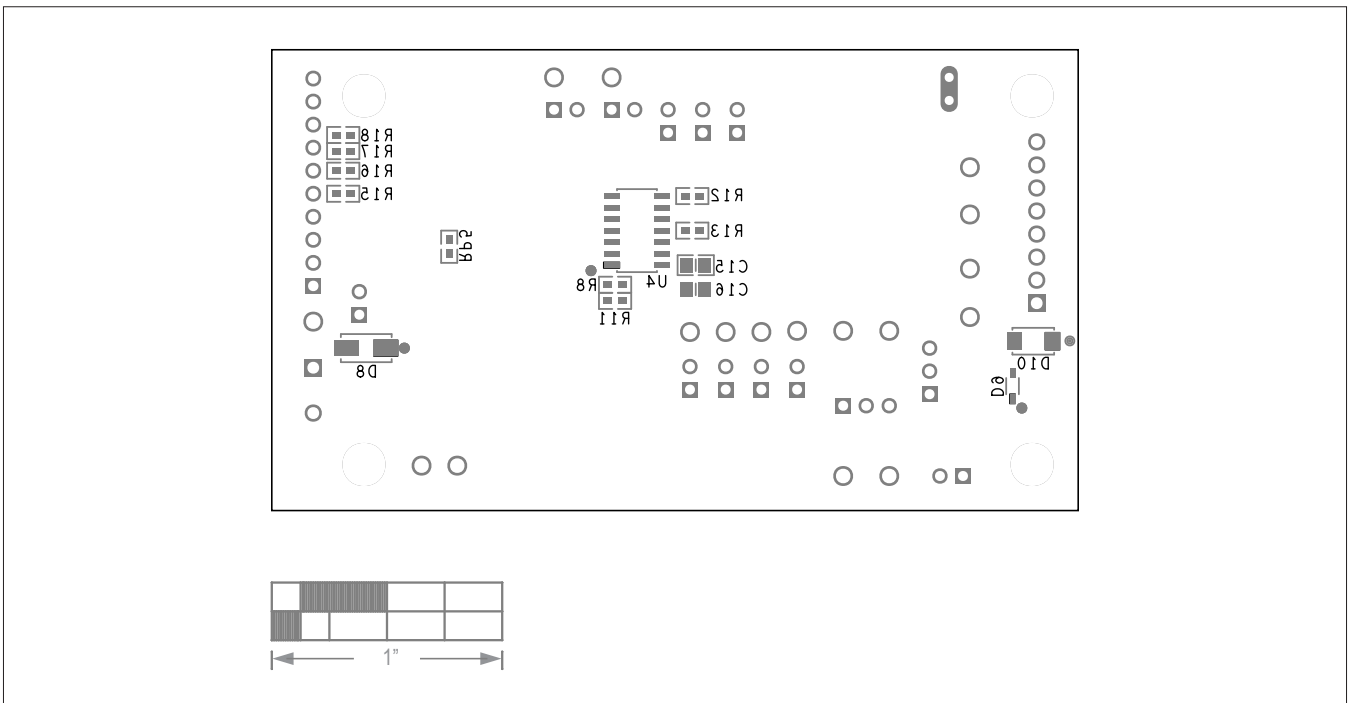

MAX14919A EV Kit PCB Layout—Bottom Silkscreen

Revision History

REVISION NUMBER	REVISION DATE	DESCRIPTION	PAGES CHANGED
0	7/21	Initial release	—

For pricing, delivery, and ordering information, please visit Maxim Integrated's online storefront at <https://www.maximintegrated.com/en/storefront/storefront.html>.

Maxim Integrated cannot assume responsibility for use of any circuitry other than circuitry entirely embodied in a Maxim Integrated product. No circuit patent licenses are implied. Maxim Integrated reserves the right to change the circuitry and specifications without notice at any time.