

Datasheet

Single tier modular shelving system



RS modular shelving

This storage system is the latest in modular racking and has been designed as a fully integrated system, in which each bay is easy to assemble and can be slotted together into standard modules.

With such flexibility, a wide range of layouts and designs may be created to accommodate the smallest workshop to the largest stores or office. The system is quick and easy to erect without the need for time-consuming nut and bolt assembly. All the major components are manufactured from 18swg steel and epoxy powder coated in either medium or dark grey stove enamel. This shelving system is also compatible with the older RS rack system – brown and beige in colour.

This modular system provides a cost effective and adaptable solution to the problem of mass storage.

This data sheet shows how easy it is to build the system in a step by step guide including some of the safety precautions that are essential in building any shelving system.

Site requirements

The proposed site should have a reasonably level floor (small local variations may be accommodated by the use of packing shims, one supplied with each upright). The base material should be concrete or any other suitable flooring which can withstand the loadings.

Tools you will need

To aid the quick construction of the basic and additional bays the following tools will be required.

- Spirit level
- Small screwdriver
- Small set of steps
- Soft headed hammer.

The major components

The following components are used to build the individual bays and the additional bays.

Base unit

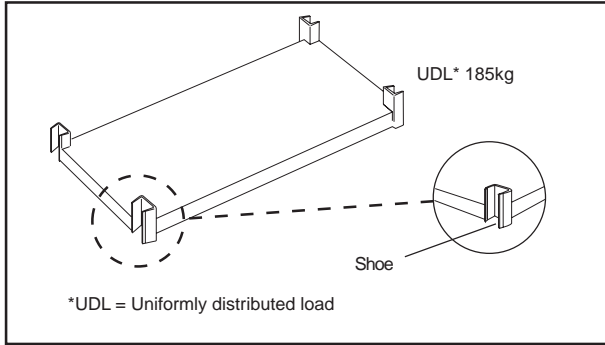

The base unit is used to hold the uprights or CV (Centrafour Vertical). The base unit also helps maintain the bay dimensions, acts as a lower storage level and is integral to the overall strength of the unit.

The steel base shelf has four shoes welded one at each corner and a groove at the rear of the base. This unit is used on all basic bays and additional bays.

Top cover

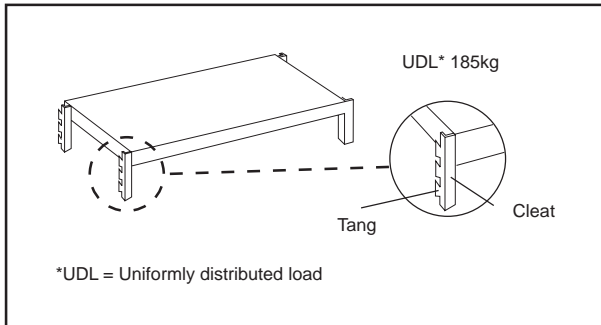

The top cover is used to hold the CV rigid and maintain the top bay dimensions. The steel cover has four shoes welded one at each corner.

This item is used on all basic and additional bays.

Uprights (CV = Centrafour Vertical)

This structural component forms the **Shelves and clips**

framework of all bays. All shelves and ancillary equipment clip into this member.



Shelves and clips

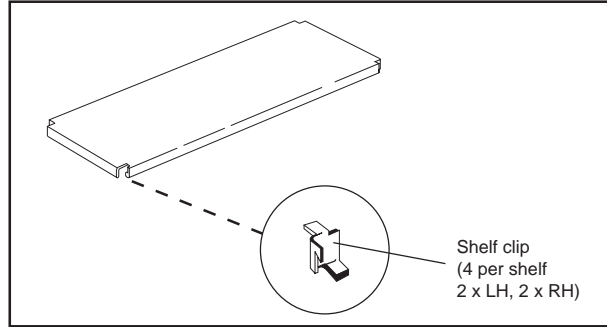

Shelves are manufactured in cold reduced steel CR4 to BS 1449 part 1, are 1.0m wide and 500mm deep. They have a thickness of 20swg and are available in a light grey stove enamel finish.

2.6mm clips are also available, 4 per shelf in each pack. There are two types, a left hand and right hand version, 2 of each required to fit a shelf. The clips locate in the slots of uprights (CVs).

Shelves can be adjusted using the clips at 50mm intervals on the uprights.

Top cap

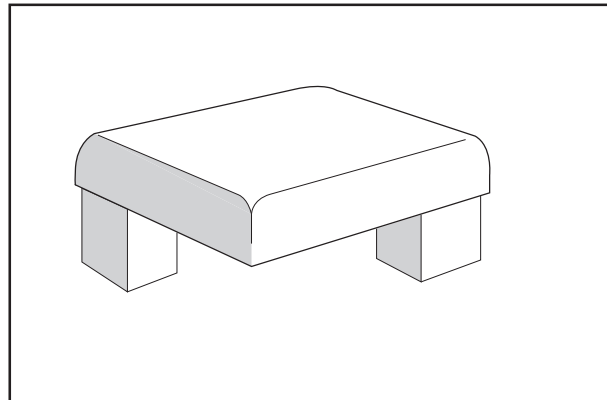

Manufactured from a durable polypropylene the upright or CV top cap forms a seal over the upright and enhances appearance. One supplied with each upright.

Packer (base plate)

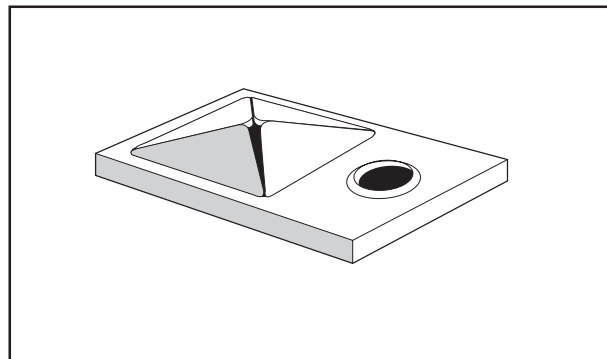

The packer or base plate should be fitted under the upright or CV to spread the load and prevent the section punching into the floor. Manufactured from 2.6mm CR4 steel.

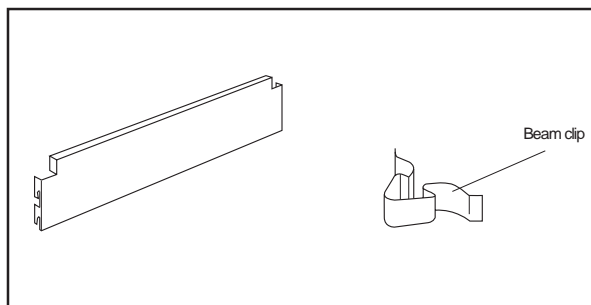
End of row and top shelf beams

Fitted at the top of each bay they maintain the bay dimensions to act as a top storage level. To prevent accidental dislodgement of cross members, the beam clip is simply locked into place on either side of the beam.

Calculating weight loadings for the RS modular shelving system

The basic and additional bays shown above must not have a combined UDL (uniformly distributed load) that exceeds 945kg. Therefore each bay must not exceed 945kg and the shelves must not individually exceed 135kg UDL.

The base and top covers must also not exceed 185kg UDL each.

The example shows two bays with different weight loadings. The bay on the left shows a wider spacing arrangement of shelves with 4 lots of shelving used and the top cover also used. The bay on the right shows 6 lots of shelving being used without the top cover loaded. If the top cover was used it would bring the overall weight over the maximum 945kg.

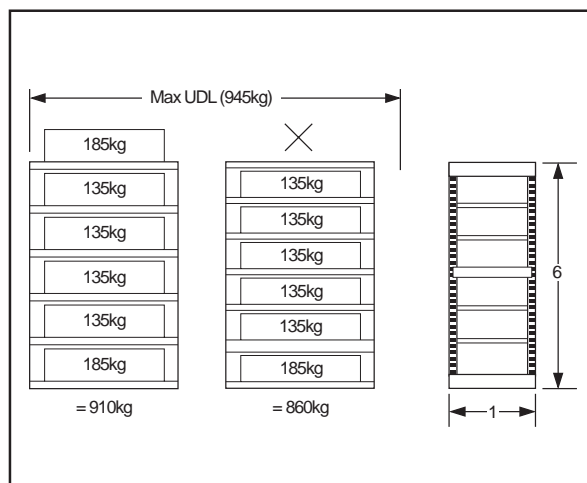

6:1 height to depth ratio

The total height of the bay must not exceed more than six times the bay depth, without securing the structure, ie. a bay 500mm deep must not exceed 3000mm high (6 × 500mm) without suitable wall or floor fixings.

Modular shelving system

The basic bay shown above is easily built and consists of four uprights, base, top, cross and side members. Each upright has slots on a 50mm pitch for shelf height adjustment on the four faces.

The bases can be easily ganged together to form any number of bays on the same level. This is easily achieved by adding the additional bays.

Both the basic and additional bays are available in two depths according to your storage requirements. Each basic and additional bay is 2m high and 1m wide.

Description	Wt (kg)	RS stock no.
500mm deep bay	44	231-226
500mm additional bay	33	231-248

For the ends of the basic and additional bays it is possible to simply add a louvred panel to provide even greater storage density. The louvre will accept a wide range of polypropylene storage bins.

Description	Wt (kg)	RS stock no.
500mm louvre panel	23	231-282

Tough **RS** polypropylene storage bins are available in six different sizes and five different colours. They have been designed to either interstack or be mounted on louvred panels. The front face includes a card holder for identification.

Size	Bin dimensions			Louvres used
	W	D	H	
1	100	90	50	2
2	101	167	76	3
3	150	240	130	6
4	205	350	130	9
5	205	350	181	12
6	419	376	180	24

Bin size	Bin colour	RS stock no.
1	Red	551-716
1	Green	551-722
1	Orange	551-738
1	Blue	519-015
1	Yellow	515-861
2	Red	551-744
2	Green	551-750
2	Orange	551-766
2	Blue	519-021
2	Yellow	515-877
3	Red	551-772
3	Green	551-788
3	Orange	551-794
3	Blue	519-037
3	Yellow	515-883
4	Red	551-801
4	Green	551-817
4	Orange	551-823
4	Blue	519-043
4	Yellow	515-899
5	Red	556-468
5	Green	551-839
5	Orange	551-845
5	Blue	519-059
5	Yellow	515-906
6	Red	556-474
6	Green	551-851
6	Orange	551-867
6	Blue	519-065
6	Yellow	515-912

Shelf sets

High grade sheet steel shelves supplied in pairs ready to use with side members that slot into the shelf clips provided. One shelf is required per level providing a max weight loading of 135kg evenly distributed.

Standard epoxy coated shelves		
	Wt (kg)	RS stock no.
500mm deep	45	231-260



High density storage can be achieved using the polypropylene containers specifically designed for the storage of small parts. Each container comes complete with a range of labels for identification of contents.



Standard polypropylene component storage containers

Size	Container dimensions			RS stock no.	Divider type
	L	W	H		
1	400	94	80	515-287	A
2	400	188	80	515-293	B
3	400	188	115	515-300	C
4	500	94	80	515-316	A
5	500	188	80	515-322	B
6	500	188	115	515-338	C

Divider type	RS stock no.
A	515-344
B	515-350
C	515-366

Security bay/cabinet



The security pack is designed to fit any existing bay 2000mm high × 1000mm wide × 500mm deep, to create a cabinet with secure sides and back and provide a lockable door.

The cabinet comes complete with two equal sized doors plus fittings. The doors have hinged projections that fit into corresponding holes at the ends of the top and bottom beams to create a hinge. The lock mechanism is then fitted to the right hand door to complete.

The top and bottom beams may be placed at any suitable height within the bay as these beams simply clip into the upright. Retaining clips should be used when the height has been set.

Solid steel cladding is used for both the sides and back of the bay. These are supplied in two sections for ease of erection, and fit between the bay uprights rather like a picture frame. Retaining clips are used to prevent any movement of the cladding.

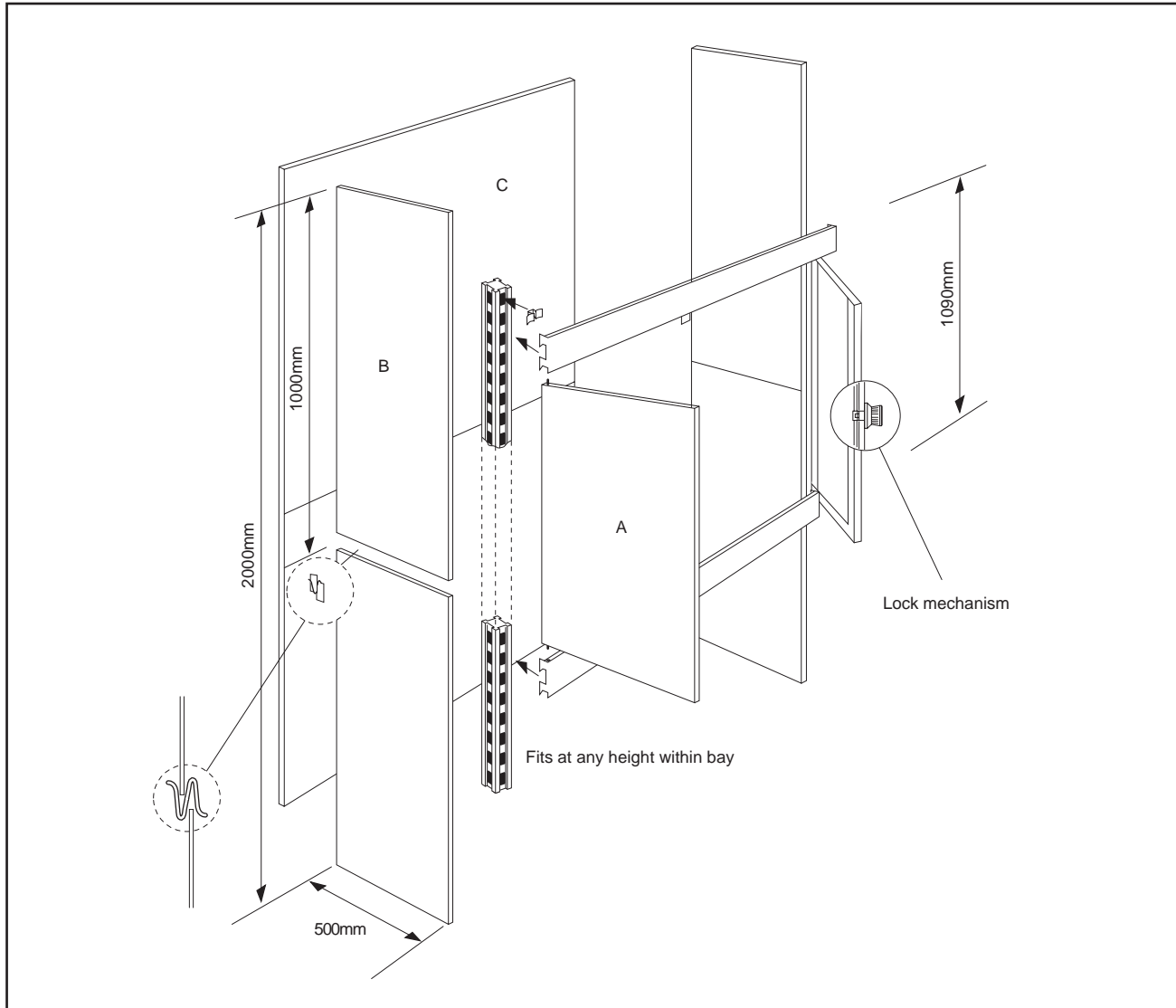
Shelves can be placed in the bay when doors and cladding are fitted. This enables many small parts to be stored and securely held in a separate location.



Secure cabinet **RS** stock no. 231-311

Weight of secure cabinet _____ 35 kg

Secure cabinet height _____ 1090mm

Depth of secure cabinet _____ 500mm