



Main

Range of product	Harmony XB5
Product or component type	Annunciator
Bezel material	Dark grey plastic
Mounting diameter	22 mm
Head type	Standard
Cap/operator or lens colour	Black

Complementary

Supply circuit type	AC/DC
Supply frequency	50/60 Hz
Signalling type	Continuous or intermittent tone
Noise level	90 dB 6.8 kHz 0.1 m +/- 10 %
Resistance to high pressure washer	9000000 Pa at 80 °C, distance : 0.1 m
Height	29 mm
Width	29 mm
Depth	55 mm
Product weight	0.024 kg
Current consumption	<= 28 mA
[Us] rated supply voltage	24 V +/- 10 %

Environment

Protective treatment	TH
Ambient air temperature for storage	-40...70 °C
Ambient air temperature for operation	-40...70 °C
Overvoltage category	Class II conforming to IEC 60536
Electrical shock protection class	Class II conforming to IEC 60536
NEMA degree of protection	NEMA 4X NEMA 13
Standards	IEC 60947-5-1 EN 60947-1 EN 60947-5-1 EN 60947-5-4 CSA C22.2 No 14 IEC 60947-5-4 IEC 60947-1 UL 508 JIS C8201-5-1 JIS C8201-1 IEC 60529 EN 50102 IEC 50102
Product certifications	UL listed CSA BV

IP degree of protection	IP20 IP66 IP67 IP69 IP69K
IK degree of protection	IK05 IK03

Packing Units

Unit Type of Package 1	PCE
Number of Units in Package 1	1
Package 1 Height	2.800 cm
Package 1 Width	3.000 cm
Package 1 Length	5.400 cm
Package 1 Weight	28 g
Unit Type of Package 2	S01
Number of Units in Package 2	88
Package 2 Height	15.000 cm
Package 2 Width	15.000 cm
Package 2 Length	40.000 cm
Package 2 Weight	2.696 kg

Offer Sustainability

Sustainable offer status	Green Premium product
REACH Regulation	REACH Declaration
EU RoHS Directive	Pro-active compliance (Product out of EU RoHS legal scope) EU RoHS Declaration
Mercury free	Yes
China RoHS Regulation	China RoHS Declaration
RoHS exemption information	Yes
Environmental Disclosure	Product Environmental Profile
WEEE	The product must be disposed on European Union markets following specific waste collection and never end up in rubbish bins
California proposition 65	WARNING: This product can expose you to chemicals including: Lead and lead compounds, which is known to the State of California to cause cancer and birth defects or other reproductive harm. For more information go to www.P65Warnings.ca.gov

Contractual warranty

Warranty	18 months
----------	-----------

Dimensions

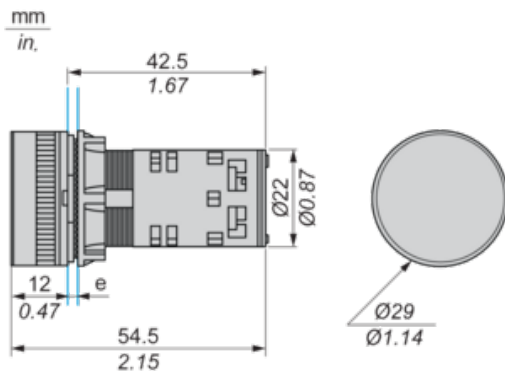

e: Clamping thickness: 1 to 6 mm / 0.04 to 0.24 in.

Panel Cut-out for Buzzer

Connection by Screw Clamp Terminals

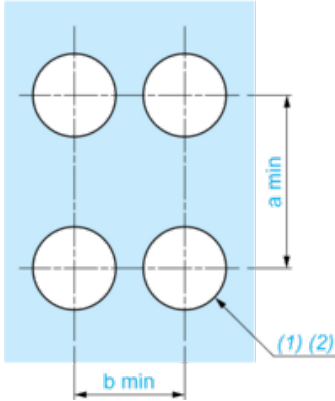

(1) Diameter on finished panel or support

(2) $\text{Ø}22.5 \text{ mm}$ recommended ($\text{Ø}22.3 \text{ }_0^{+0.4}$) / $\text{Ø}0.89 \text{ in.}$ recommended ($\text{Ø}0.88 \text{ in. }_0^{+0.016}$)

Connections	a in mm	a in in.	b in mm	b in in.
By screw clamp terminals or plug-in connector	40	1.57	30	1.18

Cabling of Annunciators

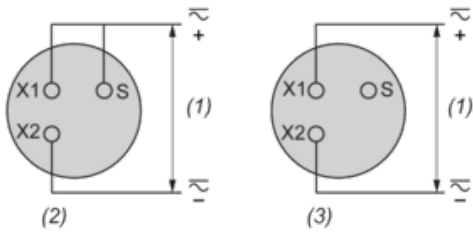

- (1) Supply
- (2) Intermittent
- (3) Continuous