

# Datasheet

## Steel External Circlip, 25mm Shaft Diameter, 23.9mm Groove Diameter

RS Stock number 289-310



**STANDARD EXTERNAL CIRCLIPS EUROPEAN SPECIFICATIONS**

**D1400** INCORPORATING DIN 471 & BS3673 Pt.4



All dimensions in mm

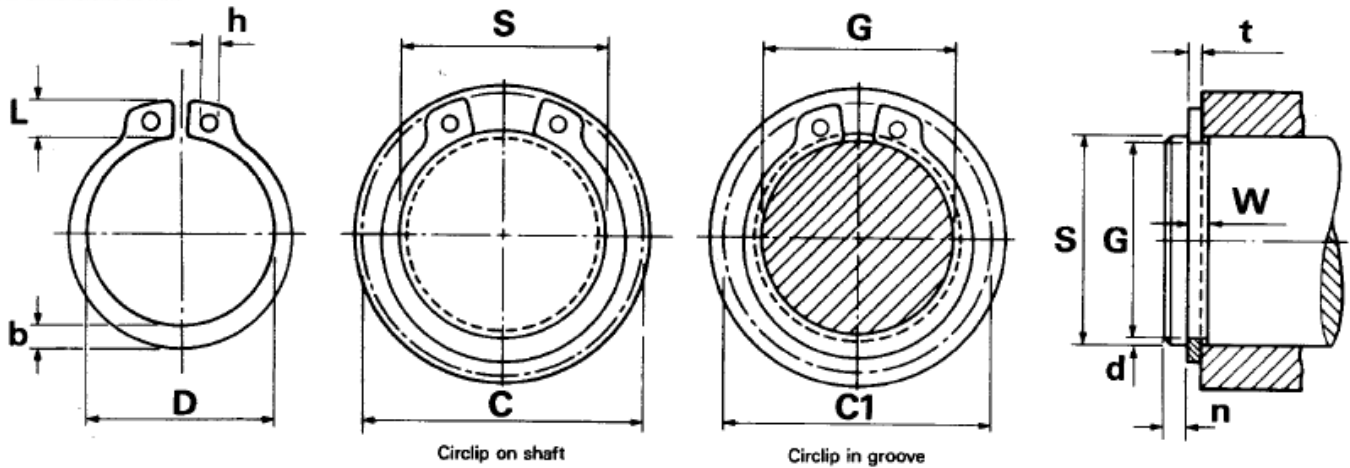

Lug for sizes 3 to 9 mm



Alternative lug for sizes 4-8 mm

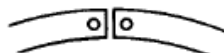

Most sizes over 185 mm are without lugs



Beam configuration on some larger sizes

Sizes printed in blue are preferred sizes

† Thrust load calculations see pages 9 & 10

Shaft S	Groove (G)						Circlip (F)									Wt. (kg/k)	Tc† (N)	Tg† (N)
	G	Tol.	W	Tol.	n (min)	d ~	t	Tol.	D	Tol.	C	C1	L (max)	b ~	h (min)			
3	2.8	+0.00 -0.04	0.50	+0.14 -0.00	0.3	0.10	0.40	+0.00 -0.05	2.7	+0.04 -0.15	7.0	6.6	1.9	0.8	1.0	0.02	1170	110
4	3.8	+0.00	0.50		0.3	0.10	0.40		3.7		8.6	8.2	2.2	0.9	1.0	0.03	1600	150
5	4.8		0.70		0.3	0.10	0.60		4.7		10.3	9.8	2.5	1.1	1.0	0.08	2900	190
6	5.7	-0.048	0.80		0.5	0.15	0.70		5.6		11.7	11.1	2.7	1.3	1.2	0.13	4100	340
7	6.7	+0.00 -0.06	0.90		0.5	0.15	0.80		6.5		13.5	12.9	3.1	1.4	1.2	0.18	5500	400
8	7.6		0.90		0.6	0.20	0.80		7.4		14.7	14.0	3.2	1.5	1.2	0.20	6200	600
9	8.6		1.10		0.6	0.20	1.00		8.4		16.0	15.2	3.3	1.7	1.2	0.32	8800	680
10	9.6	+0.00 -0.11	1.10		0.6	0.20	1.00		9.3		17.0	16.2	3.3	1.8	1.5	0.40	9700	750
11	10.5		1.10		0.8	0.25	1.00		10.2		18.0	17.1	3.3	1.8	1.5	0.41	10700	1040
12	11.5		1.10		0.8	0.25	1.00		11.0		19.0	18.1	3.3	1.8	1.7	0.45	11700	1130
13	12.4		1.10		0.9	0.30	1.00		11.9		20.2	19.2	3.4	2.0	1.7	0.52	12700	1470
14	13.4	+0.00 -0.13	1.10		0.9	0.30	1.00		12.9		21.4	20.4	3.5	2.1	1.7	0.56	13600	1580
15	14.3		1.10	1.1	0.35	1.00	13.8	22.6	21.5	3.6	2.2	1.7	0.62	14600	1980			
16	15.2		1.10	1.2	0.40	1.00	14.7	23.8	22.6	3.7	2.2	1.7	0.69	15600	2410			
17	16.2		1.10	1.2	0.40	1.00	15.7	25.0	23.8	3.8	2.3	1.7	0.77	16600	2560			
18	17.0	+0.00 -0.13	1.30	1.5	0.50	1.20	16.5	26.2	24.8	3.9	2.4	2.0	0.99	21000	3390			
19	18.0		1.30	1.5	0.50	1.20	17.5	27.2	25.8	3.9	2.5	2.0	1.10	22200	3580			
20	19.0		1.30	1.5	0.50	1.20	18.5	28.4	27.0	4.0	2.6	2.0	1.18	23400	3770			
21	20.0		1.30	1.5	0.50	1.20	19.5	29.6	28.2	4.1	2.7	2.0	1.26	24500	3960			
22	21.0		1.30	1.5	0.50	1.20	20.5	30.8	29.4	4.2	2.8	2.0	1.39	25700	4150			
23	22.0		+0.00 -0.21	1.30	1.5	0.50	1.20	21.5	32.0	30.6	4.3	2.9	2.0	1.54	26900	4340		
24	22.9	1.30		1.7	0.55	1.20	22.2	33.2	31.7	4.4	3.0	2.0	1.52	28000	4980			
25	23.9	1.30		1.7	0.55	1.20	23.2	34.2	32.7	4.4	3.0	2.0	1.70	29200	5180			
26	24.9	1.30		1.7	0.55	1.20	24.2	35.5	33.9	4.5	3.1	2.0	1.75	30400	5390			
27	25.6	1.30		2.1	0.70	1.20	24.9	36.7	34.8	4.6	3.1	2.0	1.89	31600	7130			
28	26.6	+0.00 -0.25		1.60	2.1	0.70	1.50	25.9	37.9	36.0	4.7	3.2	2.0	2.47	40900	7390		
29	27.6		1.60	2.1	0.70	1.50	26.9	39.1	37.2	4.8	3.4	2.0	2.75	42400	7650			
30	28.6		1.60	2.1	0.70	1.50	27.9	40.5	38.6	5.0	3.5	2.0	2.93	43800	7920			
32	30.3		1.60	2.6	0.85	1.50	29.6	43.0	40.7	5.2	3.6	2.5	3.02	46700	10300			
33	31.3		1.60	2.6	0.85	1.50	30.5	44.0	41.7	5.2	3.7	2.5	3.30	48200	10600			
34	32.3		+0.00 -0.30	1.60	2.6	0.85	1.50	31.5	45.4	43.1	5.4	3.8	2.5	3.72	49700	10900		
35	33.0	1.60		3.0	1.00	1.50	32.2	46.8	44.2	5.6	3.9	2.5	3.78	51100	13200			
36	34.0	1.85		3.0	1.00	1.75	33.2	47.8	45.2	5.6	4.0	2.5	4.55	51400	13600			
38	36.0	1.85		3.0	1.00	1.75	35.2	50.2	47.6	5.8	4.2	2.5	5.08	54800	14300			
40	37.5	1.85		3.8	1.25	1.75	36.5	52.6	49.5	6.0	5.0	2.5	5.54	56600	18800			
42	39.5	+0.00 -0.30		1.85	3.8	1.25	1.75	38.5	55.7	52.5	6.5	5.0	2.5	5.99	59500	19800		
45	42.5		1.85	3.8	1.25	1.75	41.5	59.1	55.9	6.7	5.0	2.5	6.75	63700	21200			
46	43.5		1.85	3.8	1.25	1.75	42.5	60.1	56.9	6.7	5.0	2.5	7.24	65100	21700			
47	44.5		1.85	3.8	1.25	1.75	43.5	61.3	58.1	6.8	5.0	2.5	7.30	66500	22100			
48	45.5		1.85	3.8	1.25	1.75	44.5	62.5	59.3	6.9	5.0	2.5	7.51	67900	22600			
50	47.0		+0.00 -0.30	2.15	4.5	1.50	2.00	45.8	64.5	60.8	6.9	5.5	2.5	9.88	80900	28300		
52	49.0	2.15		4.5	1.50	2.00	47.8	66.7	63.0	7.0	5.5	2.5	9.53	84100	29400			
54	51.0	2.15		4.5	1.50	2.00	49.8	69.0	65.2	7.1	5.5	2.5	10.30	87400	30500			
55	52.0	2.15		4.5	1.50	2.00	50.8	70.2	66.4	7.2	5.5	2.5	10.41	89000	31100			
56	53.0	2.15		4.5	1.50	2.00	51.8	71.6	67.6	7.3	5.5	2.5	10.50	90600	31700			
58	55.0	+0.00 -0.30		2.15	4.5	1.50	2.00	53.8	73.6	69.6	7.3	5.6	2.5	12.47	93800	32800		
60	57.0		2.15	4.5	1.50	2.00	55.8	75.6	71.8	7.4	5.8	2.5	13.69	97100	33900			
62	59.0		2.15	4.5	1.50	2.00	57.8	77.8	74.0	7.5	6.0	2.5	12.36	100000	35100			
63	60.0		2.15	4.5	1.50	2.00	58.8	79.0	75.2	7.6	6.2	2.5	13.10	102000	35600			
65	62.0		2.65	4.5	1.50	2.50	60.8	81.4	77.6	7.8	6.3	3.0	20.44	131000	36800			

Shaft S	Groove (G)						Circlip (F)									Wt. (kg/k)	Tc† (N)	Tg† (N)
	G	Tol.	W	Tol.	n (min)	d ~	t	Tol.	D	Tol.	C	C1	L (max)	b ~	h (min)			
67	64.0		2.65		4.5	1.50	2.50		62.5		83.6	79.8	7.9	6.4	3.0	20.43	135000	37900
68	65.0		2.65		4.5	1.50	2.50		63.5		84.4	81.0	8.0	6.5	3.0	19.55	138000	38500
70	67.0		2.65		4.5	1.50	2.50		65.5		87.0	83.2	8.1	6.6	3.0	22.13	142000	39600
72	69.0	+0.00	2.65	+0.14	4.5	1.50	2.50	+0.00	67.5		89.2	85.4	8.2	6.8	3.0	21.60	146000	40700
75	72.0	-0.30	2.65	-0.00	4.5	1.50	2.50	-0.07	70.5	+0.46	92.7	88.8	8.4	7.0	3.0	24.65	152000	42400
77	74.0		2.65		4.5	1.50	2.50		72.5	-1.10	94.9	91.0	8.5	7.2	3.0	24.26	156000	43500
78	75.0		2.65		4.5	1.50	2.50		73.5		96.1	92.2	8.6	7.3	3.0	28.10	158000	44100
80	76.5		2.65		5.3	1.75	2.50		74.5		98.1	93.7	8.6	7.4	3.0	26.68	162000	52800
82	78.5		2.65		5.3	1.75	2.50		76.5		100.3	95.9	8.7	7.6	3.0	28.35	166000	54100
85	81.5		3.15		5.3	1.75	3.00		79.5		103.3	98.9	8.7	7.8	3.5	35.40	206000	56100
88	84.5	+0.00	3.15		5.3	1.75	3.00	+0.00	82.5		106.5	102.0	8.8	8.0	3.5	39.85	214000	58100
90	86.5	-0.35	3.15		5.3	1.75	3.00	-0.08	84.5		108.5	104.0	8.8	8.2	3.5	38.89	218000	59400
95	91.5		3.15		5.3	1.75	3.00		89.5		114.8	111.0	9.4	8.6	3.5	42.39	231000	62700
98	94.5		3.15		5.3	1.75	3.00		91.5		118.6	114.0	9.8	9.0	3.5	54.00	238000	64700
100	96.5		3.15		5.3	1.75	3.00		94.5		120.2	116.0	9.6	9.0	3.5	48.86	243000	66000
102	98.0		4.15		6.0	2.00	4.00		95.0	+0.54	122.4	118.0	9.7	9.2	3.5	68.73	330000	76900
105	101.0		4.15		6.0	2.00	4.00		98.0	-1.30	126.2	122.0	10.1	9.3	3.5	73.16	340000	79200
108	104.0	+0.00	4.15		6.0	2.00	4.00		100.0		129.0	124.0	10.0	9.5	3.5	83.45	349000	81400
110	106.0	-0.54	4.15		6.0	2.00	4.00		103.0		131.2	127.0	10.1	9.6	3.5	75.24	356000	82900
115	111.0		4.15		6.0	2.00	4.00		108.0		137.3	133.0	10.6	9.8	3.5	78.65	327000	86700
120	116.0		4.15		6.0	2.00	4.00		113.0		143.1	138.0	11.0	10.2	3.5	85.58	388000	90500
125	121.0		4.15		6.0	2.00	4.00		118.0		149.0	144.0	11.4	10.4	4.0	99.62	404000	94200
130	126.0		4.15		6.0	2.00	4.00		123.0		154.4	150.0	11.6	10.7	4.0	98.10	421000	98000
135	131.0		4.15		6.0	2.00	4.00		128.0		159.8	155.0	11.8	11.0	4.0	113.40	437000	102000
140	136.0		4.15		6.0	2.00	4.00	+0.00	133.0		165.2	160.0	12.0	11.2	4.0	119.18	453000	106000
145	141.0		4.15		6.0	2.00	4.00	-0.10	138.0		170.6	166.0	12.2	11.5	4.0	128.53	470000	109000
150	145.0		4.15		7.5	2.50	4.00		142.0		177.3	171.0	13.0	11.8	4.0	132.80	485000	141000
155	150.0	+0.00	4.15	+0.18	7.5	2.50	4.00		146.0	+0.63	182.3	176.0	13.0	12.0	4.0	136.06	501000	146000
160	155.0	-0.63	4.15	-0.00	7.5	2.50	4.00		151.0	-1.50	188.0	182.0	13.3	12.2	4.0	137.50	518000	151000
165	160.0		4.15		7.5	2.50	4.00		155.5		193.4	187.0	13.5	12.5	4.0	151.96	534000	156000
170	165.0		4.15		7.5	2.50	4.00		160.5		198.4	192.0	13.5	12.9	4.0	169.00	550000	160000
175	170.0		4.15		7.5	2.50	4.00		165.5		203.4	197.0	13.5	12.9	4.0	173.70	566000	165000
180	175.0		4.15		7.5	2.50	4.00		170.5		210.0	204.0	14.2	13.5	4.0	188.00	582000	170000
185	180.0		4.15		7.5	2.50	4.00		175.5		215.2	209.0	14.3	13.5	4.0	193.00	598000	174000
190	185.0		4.15		7.5	2.50	4.00		180.5		220.0	214.0	14.2	14.0	4.0	203.00	615000	179000
195	190.0		4.15		7.5	2.50	4.00		185.5		225.0	219.0	14.2	14.0	4.0	209.50	631000	184000
200	195.0		4.15		7.5	2.50	4.00		190.5		230.0	224.0	14.2	14.0	4.0	214.00	647000	188000
205	199.0	+0.00	5.15		9.0	3.00	5.00		193.0		235.0	228.0	14.2	14.0	4.0	278.00	721000	232000
210	204.0	-0.72	5.15		9.0	3.00	5.00		198.0	+0.72	240.0	233.0	14.2	14.0	4.0	285.00	739000	238000
220	214.0		5.15		9.0	3.00	5.00		208.0	-1.70	250.0	243.0	14.2	14.0	4.0	298.50	775000	249000
230	224.0		5.15		9.0	3.00	5.00	+0.00	218.0		260.0	253.0	14.2	14.0	4.0	312.00	809000	260000
240	234.0		5.15		9.0	3.00	5.00	-0.12	228.0		270.0	263.0	14.2	14.0	4.0	326.00	844000	271000
250	244.0		5.15		9.0	3.00	5.00		238.0		280.0	272.0	14.2	14.0	4.0	340.00	880000	283000
260	252.0		5.15		12.0	4.00	5.00		245.0		294.0	285.0	16.2	16.0	5.0	414.00	915000	392000
270	262.0		5.15		12.0	4.00	5.00		255.0		304.0	295.0	16.2	16.0	5.0	430.50	950000	407000
280	272.0	+0.00	5.15		12.0	4.00	5.00		265.0	+0.81	314.0	305.0	16.2	16.0	5.0	446.50	985000	422000
290	282.0	-0.81	5.15		12.0	4.00	5.00		275.0	-2.00	324.0	315.0	16.2	16.0	5.0	463.00	1020000	437000
300	292.0		5.15		12.0	4.00	5.00		285.0		334.0	325.0	16.2	16.0	5.0	479.00	1056000	452000
310	300.0		6.20		15.0	5.00	6.00		293.0		352.2	341.0	20.2	20.0	6.0	710.50	1309000	584000
320	310.0		6.20		15.0	5.00	6.00		303.0		362.2	351.1	20.2	20.0	6.0	734.00	1351000	603000
330	320.0		6.20	+0.22	15.0	5.00	6.00		313.0		372.2	361.0	20.2	20.0	6.0	757.00	1393000	622000
340	330.0		6.20	-0.00	15.0	5.00	6.00	+0.00	323.0		382.2	371.0	20.2	20.0	6.0	780.00	1436000	641000
350	340.0		6.20		15.0	5.00	6.00	-0.18	333.0		392.2	381.0	20.2	20.0	6.0	805.00	1478000	660000
360	350.0	+0.00	6.20		15.0	5.00	6.00		343.0	+1.00	402.2	391.0	20.2	20.0	6.0	827.00	1520000	679000
370	360.0	-0.89	6.20		15.0	5.00	6.00		353.0	-2.50	412.2	401.0	20.2	20.0	6.0	850.00	1562000	697000
380	370.0		6.20		15.0	5.00	6.00		363.0		422.2	411.0	20.2	20.0	6.0	873.00	1604000	716000
390	380.0		6.20		15.0	5.00	6.00		373.0		432.2	421.0	20.2	20.0	6.0	896.00	1646000	735000
400	390.0		6.20		15.0	5.00	6.00		383.0		442.2	431.0	20.2	20.0	6.0	919.00	1689000	754000