

2

1

DATE	REV	ECN	APP'D. BY
11-18-05	B4	7388	TRM
6-1-12	B5	9491	SMN

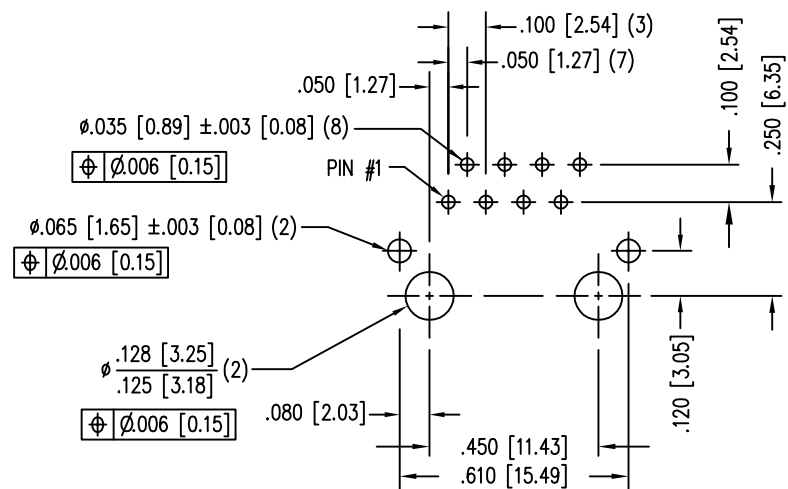
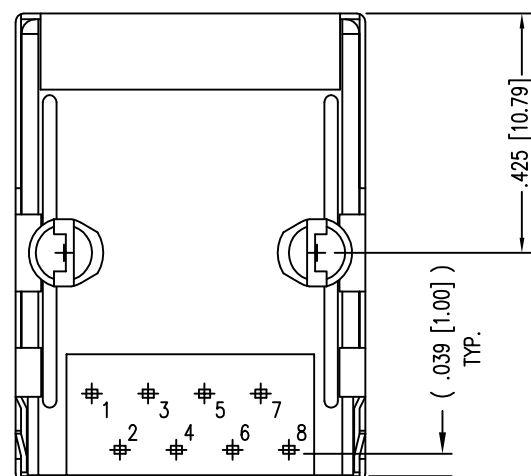
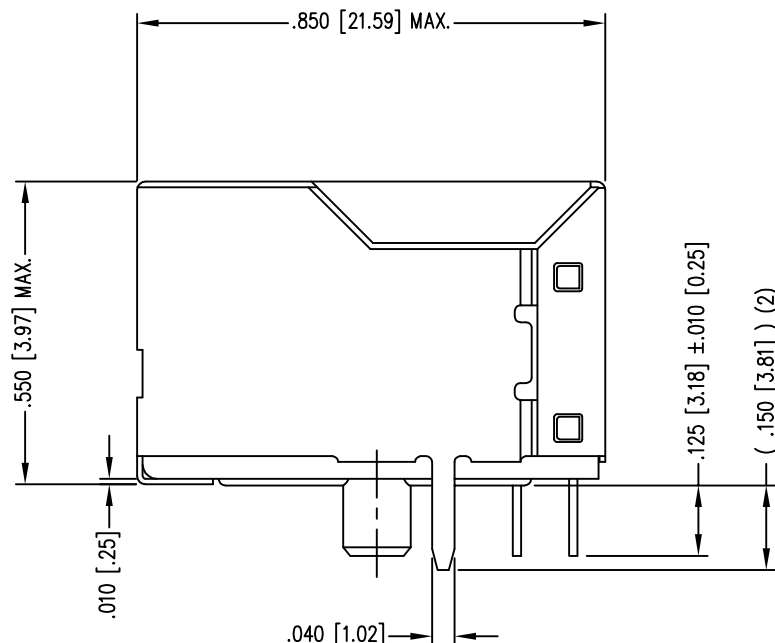
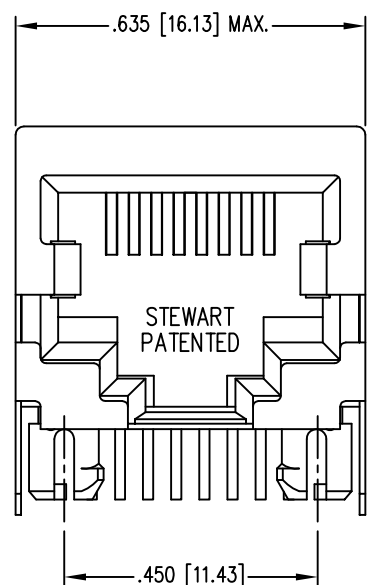

P.C.B. RECOMMENDED HOLE LAYOUT
SEEN FROM COMPONENT SIDE

ALL CENTERLINE DIMENSIONS ARE BASIC.

NOTES:

- CONNECTOR MATERIALS:
HOUSING: THERMOPLASTIC UL94 V-0
CONTACTS/SHIELD: COPPER ALLOY
SHIELD PLATING: NICKEL OR TIN
CONTACT PLATING: SELECTIVE GOLD IN CONTACT AREA
SEE CHART FOR PART NUMBER
- FOR PRODUCT SPECIFICATIONS SEE PRO22-01.
- TOLERANCES COMPLY WITH F.C.C. DIMENSION REQUIREMENTS.

30 MICRO-INCHES [0.76um]	SS-6488S-A-NF
CONTACT PLATING IN MATING AREA	PART NUMBER

THIRD ANGLE PROJECTION

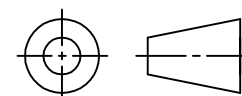

DO NOT SCALE DRAWING
DRAWING IS SUBJECT TO
CHANGE WITHOUT NOTICE

DIMENSIONS: INCHES [METRIC]

UNLESS OTHERWISE SPECIFIED
TOLERANCES ARE ±.005 [0.13]
ANGLES ARE ± 1°

SHEET NO. 1 OF 1

TITLE: EIGHT CONTACT, EIGHT POSITION, SHIELDED JACK
"-NF" NON-FLANGE

DRN BY: SAK	DATE 5-13-94
APPD BY: JW	DATE 9-23-94
DWG NO. CT640092	REV. B5

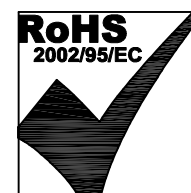

REV. 6/3/05

2

1