

SECTION B-B

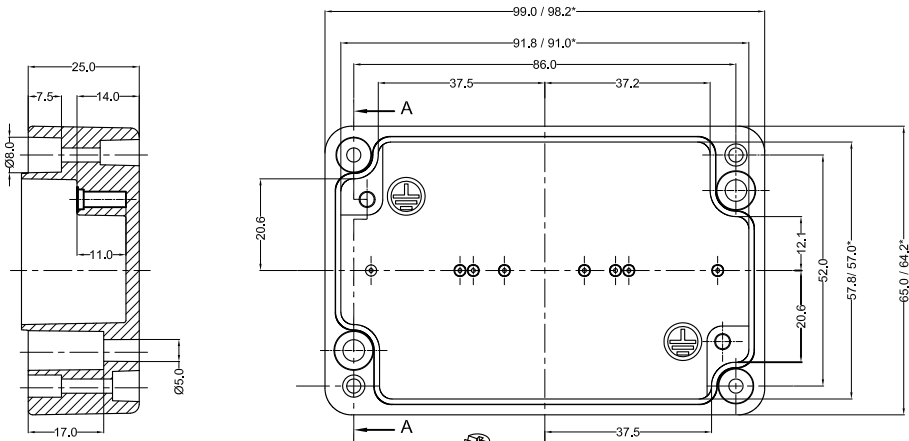

SECTION A-A

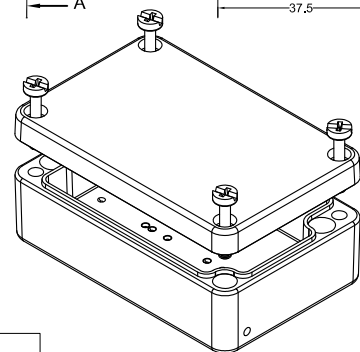

SR.NO.	PART NAME	DRAWING NO.	MATERIAL	QTY
5	SILICON GASKATE	-	SILICON	1
4	JB-EARTHING M4 SCREW	-	AISI 304 / AISI 316	4
3	JB-M4x20/7 SCREW	-	MS/304/316/COPPER	4
2	BASE JUNCTION BOX 98 X 64 X 34	Ex-R-986434-B	AISI 12	1
1	LID JUNCTION BOX 98 X 64 X 34	Ex-R-986434-L	AISI 12	1

B.O.M.

GENERAL SPECIFICATION AND AREA CLASSIFICATION:

- STANDARDS - IEC/EN 60079-0, IEC/EN 60079-7 & IEC/En 60079-31.
- MATERIAL COMPOSITION - AISI 12
- DEGREE OF PROTECTION IP66 AS PER IEC 60529 : 1989 +A1 : 2000
- GASKET MANUFACTURER - WACKER CHEMIE AG, MODEL: CENUSIL R 150 AND CONTINOUS OPERATING TEMPERATURE AS - 70 °C TO 200 °C
- MAGNESIUM, TITANIUM AND ZIRCONIUM CONTENTS ARE < 2%.
- SERVICE TEMPERATURE RANGE :- 50 °C to +135 °C
- ALL DIMENSIONS ARE IN mm. UNLESS STATED OTHERWISE.
- SURFACE WILL PLAIN FINISH OR POWDER COATED.
- THE JUNCTION BOX WILL BE MARKED WITH

II 2 G Ex e IIC Gb

II 2 D Ex tb III C Db IP 66 IP

0539

DEMKO 13 ATEX 1327771U

IECEX UL 13.0042U

10. TRADE MARK

11. TIGHTENING TORQUE - (2-3) NM

NOT TO BE REVISED WITHOUT NOTIFICATION TO THE ExCB/NOTIFIED BODY

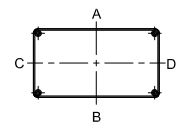

Opening Detail (Size)	NO OF HOLES SIDE A/B	Min. Distance between the opening for Side A/B (mm)	NO OF HOLES SIDE C/D	Min. Distance between the opening for Side C/D (mm)	Opening Detail (Size) PG	NO OF HOLES SIDE A/B	Min. Distance between the opening for Side A/B (mm)	NO OF HOLES SIDE C/D	Min. Distance between the opening for Side C/D (mm)	Min. Distance of last opening from the enclosure end on side A/B (mm)	Min. Distance of last opening from the enclosure end on side C/D (mm)
M12	4	7	1	-	Pg.7	4	7	1	-	15	25
M16	-	-	-	-	Pg.9	3	9	1	-	16	24
M20	-	-	-	-	Pg.11	-	-	-	-	-	-
M25	-	-	-	-	Pg.13.5	-	-	-	-	-	-
M32	-	-	-	-	Pg.16	-	-	-	-	-	-
M40	-	-	-	-	Pg.21	-	-	-	-	-	-
M50	-	-	-	-	Pg.29	-	-	-	-	-	-
M63	-	-	-	-	Pg.36	-	-	-	-	-	-
-	-	-	-	-	Pg.42	-	-	-	-	-	-
-	-	-	-	-	Pg.48	-	-	-	-	-	-

NO.	REV.NO.	DESCRIPTION	DATE	DRAWN	CHECKED

QUANTITY	MATERIAL :- AISI12 DIN230	MACH.NAME	DATE	SIGN	NAME
			17/02/14		RRPL DESIGN
			17/02/14		MANOJ DRAWN
			17/02/14		J.B. APPROVED

TOLERANCE	WEIGHT:	FINISH: NATURAL	TITLE :- JUNCTION BOX 98 x 64 x 34	SCALE	PARTNO. :-
±0.2 DIMENSIONS					
±0.2 HOLES					
±1.0° ANGLES		RJ 02			

Raychem RPG (P) Limited
 Ceal Mahesh Amnave,
 Dr. Annie Bessant Road,
 Worli, Mumbai 400030
 Web: www.raychemrpg.com

DRG. NO.
Ex-AJB-986434