



rpb[®] **T100 SERIES**[™]
SUPPLIED AIR RESPIRATOR

CONTENTS

Read all instructions and warnings before using this product.

Keep this manual for future reference.

APPROVAL LABEL	3
INTRODUCTION	4
RESPIRATORY COMPONENT CONCEPT	5
WARNINGS	6
RESPIRATOR OPERATION	8
SPECIAL OR CRITICAL USER'S INSTRUCTIONS	9
RESPIRATOR ASSEMBLY & SETUP	10
DONNING THE RESPIRATOR	12
DOFFING YOUR RESPIRATOR	15
BREATHING TUBE ASSEMBLY	16
INSPECTION CLEANING & STORAGE	17
PARTS LIST	18
NEW & REPLACEMENT T100 RESPIRATORS	20

RPB Safety Global Headquarters 2807 Samoset Rd, Royal Oak, MI 48073, USA.

T: 1-866-494-4599 F: 1-866-494-4509 E: sales.us@rpbsafety.com www.rpbsafety.com

RPB Safety Asia Pacific Headquarters 652 Halswell Junction Road, Hornby South 8042

New Zealand. T: +64-3-357-1761 F: +64-3-357-1763 E: sales.nz@rpbsafety.com

www.rpbsafety.com

RPB and Advancing Your Safety are registered trademarks of RPB Safety LLC.

For technical assistance contact our Customer Service Department
on 1-866-494-4599 or email: customerservice@rpbsafety.com

Form #: IO22
Rev: 2



RPB Safety
T. 1 866 494 4599 F. 1 866 494 4509 E. info@rpb-safety.com

TYPE C, CONTINUOUS FLOW, SUPPLIED-AIR RESPIRATOR
 THESE RESPIRATORS ARE APPROVED ONLY IN THE FOLLOWING CONFIGURATIONS

RESPIRATORY COMPONENTS																							
TC No.	Protection ¹	Model	Hood								Suspension		Breathing Tube	Alternate Flow Control Devices			Alternate Hoses			Accessories		Cautions and Limitations ²	
			07-110	07-110-S	07-110-X	07-110-SX	07-150	07-150-S	07-150-X	07-150-SX	07-920	07-126	NV2021 F	03-101	NV2016	4000-40	03-501	NV2028	NV2029	NV2027	07-123		07-926
19C-480	SA/CF	T100	X	X	X	X	X	X	X	X	X	X	X	X	X	X	X	X	X	X	X	X	ABCDEJMNO
19C-497	SA/CF	T100	X	X	X	X	X	X	X	X	X	X	X	X	X	X	X	X	X	X	X	X	ABCDEJMNO

1. PROTECTION

CF – Continuous Flow SA – Supplied Air

2. CAUTIONS AND LIMITATIONS

- A - Not for use in atmospheres containing less than 19.5% oxygen.
- B - Not for use in atmospheres immediately dangerous to life or health.
- C - Do not exceed maximum use concentrations established by regulatory standards.
- D - Air-line respirators can be used only when the respirators are supplied with respirable air meeting the requirements of CGA G-7.1 Grade D or higher quality.
- E - Use only the pressure ranges and hose lengths specified in the User’s Instructions.
- J - Failure to use and maintain this product properly could result in injury or death.
- M - All approved respirators shall be selected, fitted, used and maintained in accordance with MSHA, OSHA, and other applicable regulations.
- N - Never substitute, modify, and, or omit parts. Use only exact replacement parts in the configuration specified by the manufacturer.
- O - Refer to user instruction and/or maintenance manuals for information about use and maintenance of these respirators.
- S - Special or critical User’s Instructions and/or specific use limitations apply. Refer to User’s Instructions before donning.

rpb[®] T100 SERIES

INTRODUCTION

The T100 is approved by NIOSH as a Type C continuous flow supplied air respirator. It can be used for general purpose applications, including Pharmaceutical Manufacturing, Chemical and Pesticide Handling, Tank Cleaning, Spray Painting, and other industrial or agricultural applications in which respiratory protection is needed.

The T100 is available in two fit options, head suspension or hard hat which meets ANSIZ89.1 Type 1 Class E.

The table on pages 18-19 detail the different models, replacement hood style, material specification, Lens Protections, Bib style, Headgear and flow control devices.

The T100 has been designed for use in atmospheres that are NOT IMMEDIATELY DANGEROUS TO LIFE OR HEALTH (IDLH).

The T100 is approved for use with any one of the following flow control devices:

03-101 Constant Flow Valve (High Pressure)
NV2016 Flow Control Valve
4000-40 Cool Air Tube

WARRANTY

All RPB products are covered by a manufacturer's warranty of 3 months. The manufacturer's warranty covers defects in material, workmanship and does not cover damage caused by misuse or abuse. RPB's only obligation and your exclusive remedy shall be to repair, replace or refund the purchase price of such parts or products upon the presentation of proof of purchase. Maximum liability is in no case to exceed the value of the RPB Product involved.

RESPIRATORY COMPONENT CONCEPT

The T100 consists of 3 main components:

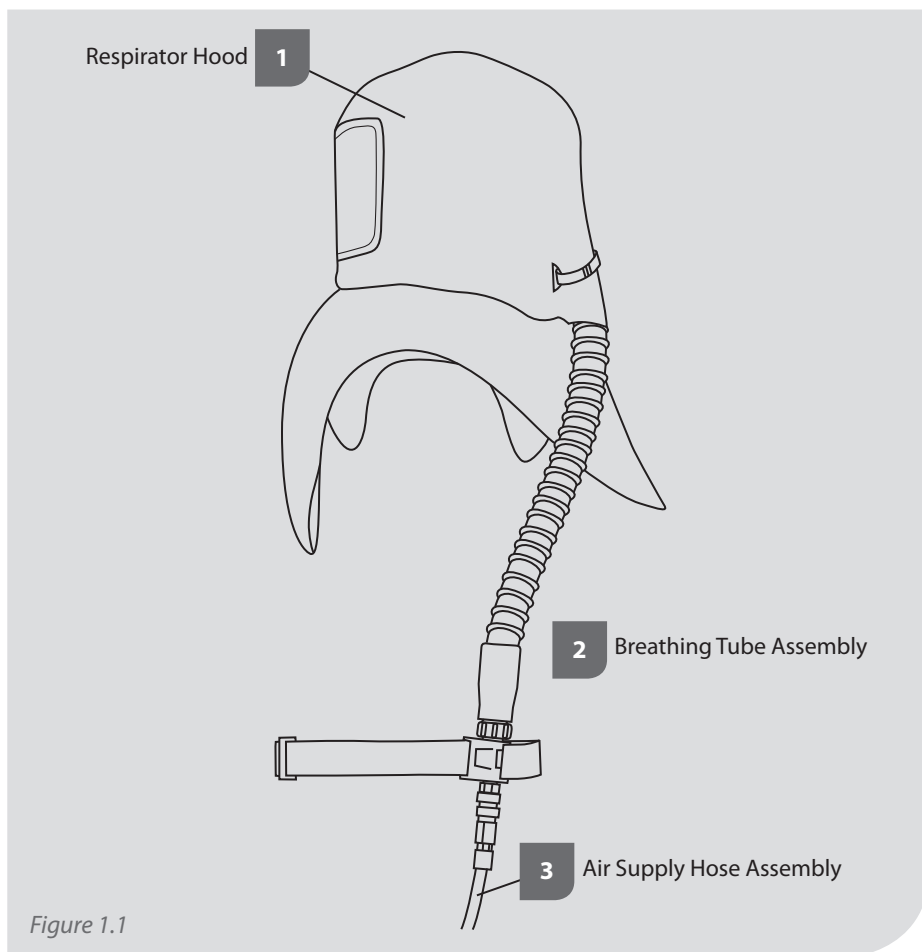

!WARNING! Failure to use genuine parts and components that are part of the NIOSH approved respirator assembly will void the approval of the entire respirator assembly.

!WARNINGS!

- 1.** Do not use this respirator until you have been trained in the respirators use, maintenance and limitations by a qualified individual (appointed by your employer) who has extensive knowledge of the T100 Series Respirator.
- 2.** Before using this respirator ensure your employer has determined that airborne contaminant concentrations do not exceed those allowed by applicable OSHA, EPA or NIOSH regulations and recommendations for continuous-flow supplied air respirators. Federal law requires that the employer measures and monitors airborne contaminant levels in the work area.
- 3.** DO NOT WEAR this respirator if any of the following conditions exist: - Atmosphere is immediately dangerous to your life or health. - You CAN NOT escape without the aid of the respirator. - Atmosphere contains less than 19.5% Oxygen. - Work area is poorly ventilated. - Contaminants are in excess of regulations or recommendations.
- 4.** Do not modify or alter this respirator. Use only parts and components that are part of the NIOSH approved respirator assembly. The use of non RPB parts voids the NIOSH approval of the entire respirator assembly.
- 5.** Inspect all components daily for signs of damage or wear that may reduce the level of protection originally provided.
- 6.** Do not use this respirator in abrasive blasting applications.
- 7.** Do not wear this respirator until you have passed a complete physical exam maybe including a lung X-ray conducted by qualified medical personnel.
- 8.** Improper use of this respirator may cause injury or death. Improper use may also cause life threatening delayed lung disease such as silicosis, pneumoconiosis or asbestosis.
- 9.** This respirator, when properly fitted and used, significantly reduces but does not completely eliminate the breathing of contaminants by the respirator wearer.
- 10.** Be certain your employer has determined that the breathing air source provides at least Grade D breathable air. The respirator must be supplied with clean breathable air at all times.
- 11.** Do not connect the respirator's air supply hose to nitrogen, toxic gases, inert gases or other non-breathable non Grade D air source. Check the air source before using the respirator. Failure to connect the supply hose to the proper air source could result in serious injury or death.
- 12.** DO NOT use this respirator in poorly ventilated areas or confined spaces unless the area is well ventilated and that the contaminant concentrations are below those recommended for this respirator. Follow all procedures for confined space entry, operation and exit as defined in applicable regulations and standards including 29 CFR 1910.146.
- 13.** Tychem® QC and SL are not flame-resistant and should not be used around heat, flame, sparks or in potential flammable or explosive environments. DuPont™ Tychem® Fabric is rated "Class 1: Normal Flammability" when tested as directed by the Flammable Fabrics Act -16 CFR Part 1610.

- 14. LEAVE WORK AREA IMMEDIATELY IF: - Any respirator component becomes damaged.
- Airflow stops or slows down. - Breathing becomes difficult. - You become dizzy, nauseous, too hot, too cold, or ill. - Vision is impaired.
- 15. The material that the respirator is made of may create static electricity under low humidity. Tychem® is coated in an antistatic agent that is water soluble so can be washed off with water. For more information regarding this Dupont® Tychem® QC, or SL, contact your employer or call 1-800-44-TYVEK.
- 16. This respirator does not provide head protection. Use 07-126 hard hat for ANSI Z89.1 head protection.
- 17. This respirator does not provide hearing protection. Approved ear muffs (ear defenders) or ear plugs must be properly fitted when exposed to noise levels that exceed OSHA permissible exposure levels.
- 18. This respirator does not provide eye protection. It is recommended that adequate eye protectors be worn at all times. 'S' models provide ANSI Z87+ eye protection.
- 19. This respirator provides only limited face protection. Use approved face protectors when exposed to face hazards. 'S' models provide ANSI Z87+ eye protection.

AIR FILTRATION & CARBON MONOXIDE MONITORING

It is an OSHA requirement that the T100 supplied air respirator be supplied with CGA G-7.1 Grade D air. To achieve this, RPB recommends using the Radex™ Airline Filter (04-900) and a Radex™ Carbon Monoxide Monitor (08-200). Further information is available by contacting RPB on 1-866-494-1599 or from your nearest authorized RPB distributor.

NIOSH – CAUTIONS & LIMITATIONS

- A) Not for use in atmospheres containing less than 19.5 percent oxygen.
- B) Not for use in atmospheres immediately dangerous to life or health.
- C) Do not exceed maximum use concentrations established by regulatory standards
- D) Air-line respirators can be used only when the respirators are supplied with respirable air meeting the requirements of CGA G-7.1 Grade D or higher quality.
- E) Use only the pressure ranges and hose lengths specified in the user's instructions
- J) Failure to properly use and maintain this product could result in injury or death.
- M) All approved respirators shall be selected, fitted, used and maintained in accordance with MSHA, OSHA, and other applicable regulations.
- N) Never substitute, modify, add or omit parts. Use only exact replacement parts in the configuration as specified by the manufacturer.
- O) Refer to user's instructions, and/or maintenance manuals for information on use and maintenance of these respirators.
- S) Special or critical user's instructions and/or specific limitations apply. Refer to user Instructions on page 9 (breathing air pressure table) before donning.

RESPIRATOR OPERATION

AIR QUALITY

This respirator must be supplied with clean breathable air at all times. Breathable air must at least meet the requirements for Type 1 gaseous air described in the Compressed Gas Association Commodity Specifications G.7.1 (Grade D or higher) and as specified by Federal Law 42 CFR 84, subpart J.84.141(b) and 29 CFR 1910.134 (i) the T100 does not purify air or filter contaminants.

AIR SOURCE

Locate the air source in a clean air environment; always use a filter on the inlet of your air source. Do not park vehicles beside your air inlet as this will cause carbon monoxide to be drawn into your air supply. Always use suitable after coolers / dryers with filters and carbon monoxide alarms to ensure clean breathable air is supplied at all times. The air should be regularly sampled to ensure that it meets Grade D requirements.

BREATHING AIR SUPPLY HOSES & FITTINGS

RPB air supply hoses and fittings that are part of the NIOSH approved respirator assembly must be used between the point of attachment and the respirator breathing air connection at the wearer's belt. The hose sections must be within the correct length and the amount of sections must be within

the number specified in the breathing air pressure table on page 9.

BREATHING AIR PRESSURE

The air pressure must be continually monitored at the point of attachment to confirm it meets Grade D requirements. Air pressure must be read from a reliable pressure gauge whilst the respirator has air flowing through it.

!WARNING!

Failure to supply the minimum required air pressure (for the length of air supply hose) at the point of attachment could result in contaminants being inhaled. This risk is due to the pressure in the helmet becoming negative when the peak inhalation flow (at high work rates) exceeds that of the supplied air.

The T100 Breathing Air Pressure table on page 9 defines the air pressure ranges needed to provide the respirator with a volume of air which falls in the required range of 6-15cfm (170-425 lts/min).

!WARNING!

Make sure you understand the Breathing Air Pressure table before using this respirator.

- Determine your air source (column 1)
- Identify your breathing tube assembly (column 2)
- Confirm the part number of the air supply hose you are using (column 3)
- Check your RPB Air Supply Hose is within the correct length (column 4)
- Set the air pressure at the point of attachment within the range specified (column 6) for your breathing tube assembly, hose length and number of hose sections. (column 5)).
- Make sure air is flowing through your respirator when setting the air pressure.

SPECIAL OR CRITICAL USER’S INSTRUCTIONS

BREATHING AIR PRESSURE TABLE

This table lists air pressure ranges needed to provide the T100 with the volume of air that falls within the required range of 6-15cfm or 170-425 lts/min according to U.S government regulations.

1. AIR SOURCE	2. BREATHING TUBE ASSEMBLY AND FLOW CONTROL DEVICES	3. AIR SUPPLY HOSE	4. SUPPLY HOSE LENGTH (FT)	5. MAX NUMBER OF SECTIONS	6. PRESSURE RANGE (PSIG)
Portable or Stationary Compressor	NV2021F / 03-101 Constant Flow Valve Assembly (High Pressure)	NV2027 (100ft) NV2028 (25ft) NV2029 (50ft)	25	1	10-14
			50	1	12-14
			100	2	17-19
			150	3	21-23
			200	4	25-27
			250	5	28-31
			300	6	31-34
Portable or Stationary Compressor	NV2021F / NV2016 Flow Control Valve Assembly	NV2027 (100ft) NV2028 (25ft) NV2029 (50ft)	25	1	27-28
			50	1	28-30
			100	2	30-33
			150	3	33-36
			200	4	36-38
			250	5	38-39
			300	6	39-43
Portable or Stationary Compressor	NV2021F / 4000-40 Climate Control Tube Assembly (Silenced Cooler)	NV2027 (100ft) NV2028 (25ft) NV2029 (50ft)	25	1	55-56
			50	1	55-57
			100	2	60-62
			150	3	65-67
			200	4	70-72
			250	5	75-77
			300	6	78-80

RESPIRATOR ASSEMBLY & SETUP

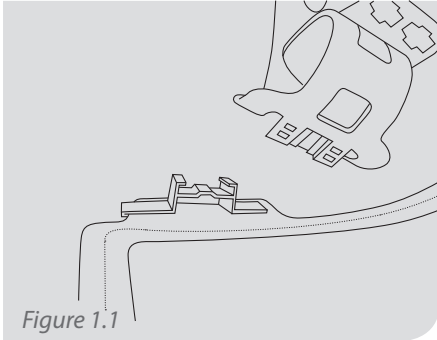

Attach 07-920 Head Suspension

Place the head suspension inside the respirator and connect it by sliding up into the two mounts located at the top of the lens.

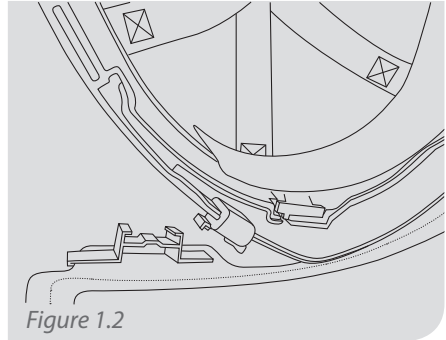

Attach 07-126 Hard Hat

Place the hard hat inside the respirator and connect it by sliding up into the two mounts located at the top of the lens.

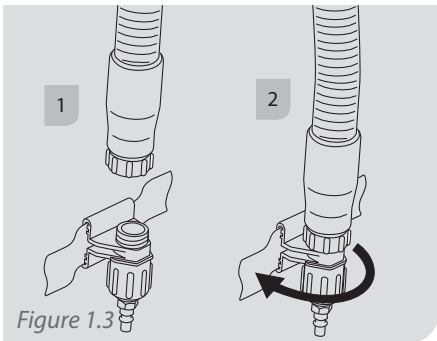

Attach Flow Control Devices

Thread on the loose running nut of the NV2021F Breathing Tube on to the Flow Control Device (03-101). Screw the running nut in a clockwise direction until tight.

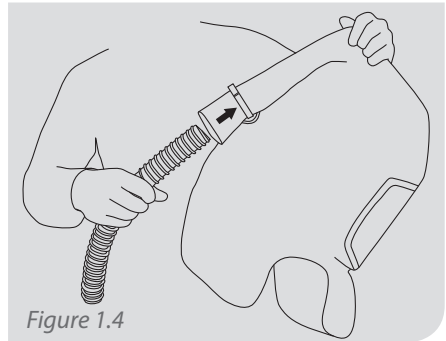

Connect Breathing Tube

Place the breathing tube into the inlet at the rear of the hood. Tighten the clamp to hold it in position. Test the connection by pulling down on the Breathing Tube.

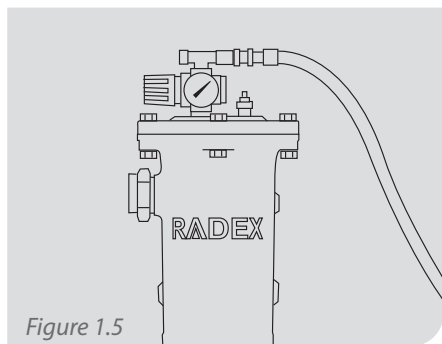

Figure 1.5

Connect air supply hose

Adjust the air pressure at the point of attachment according to the Breathing Air Pressure Table on page 9.

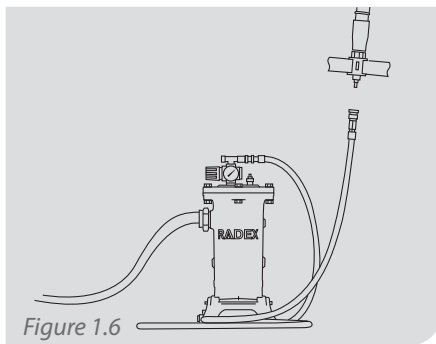

Figure 1.6

Adjust Air Pressure

Connect a RPB Air Supply Hose insuring the maximum sections and lengths are within the specifications on page 9.

PEEL OFF LENSES

Peel-off lenses (07-123) are optional and are used to increase the life of your main lens. Peel-off Lenses come in packets of 50 each with double sided tape already in place.

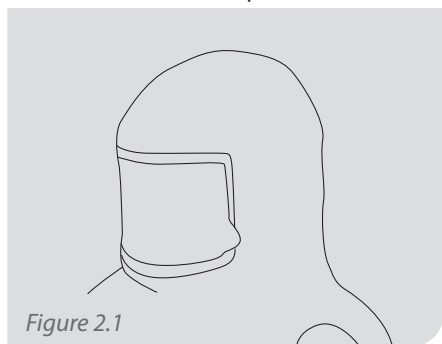

Figure 2.1

Apply Lens

Remove tape backing and adhere lens onto the center of the main lens on the respirator

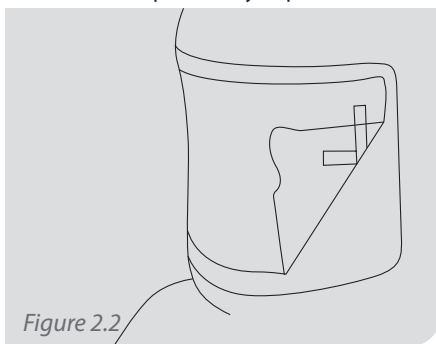

Figure 2.2

Remove Lens

Pull on the tab and the adhesive will give way.

DONNING THE RESPIRATOR

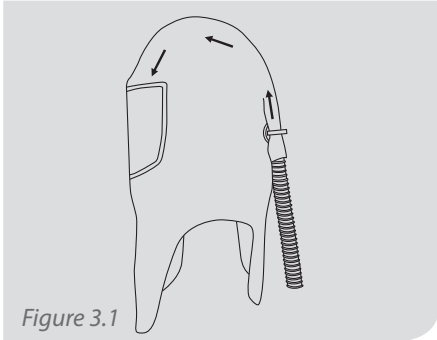

Figure 3.1

Check Air Flow

Before donning your 07-100, check that the air is flowing into it and it contains no dust, dirt or contaminates.

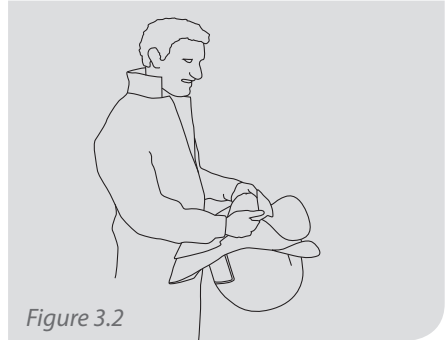

Figure 3.2

Put on Respirator

With air flowing, place the Respirator over your head, and make sure that the head suspension or hard hat is sitting comfortably and securely on your head.

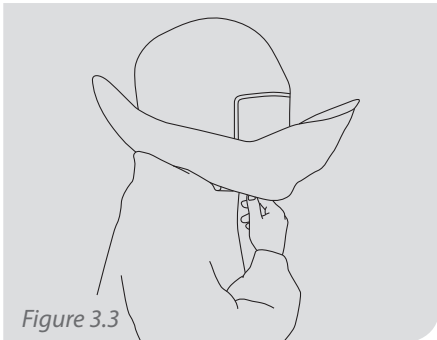

Figure 3.3

Tuck in the Collar

Tuck the inner collar into your clothing to create a positive pressure effect for the respirator. The air can also aide in cooling your body. Pull the outer collar down at the front, back and sides.

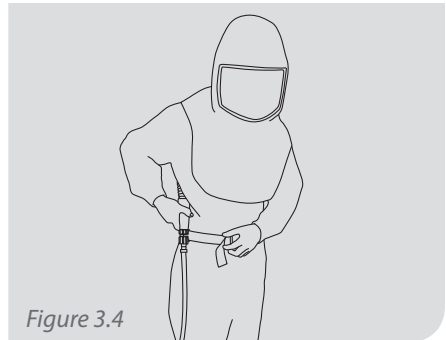

Figure 3.4

Fasten Belt

Connect the Flow Control device belt around your waist. It is recommended to have the device situated over your hip.

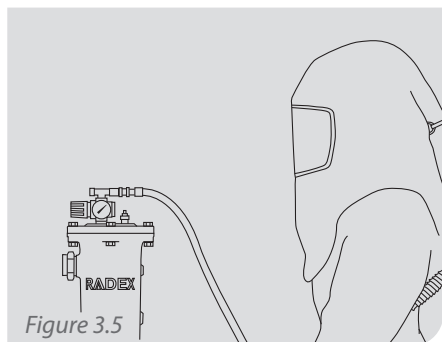

Figure 3.5

Check Air Pressure

Re-check the air pressure at the point of attachment and adjust it if necessary. Ensure you are comfortable with the flow of air inside the respirator.

YOU ARE NOW READY TO ENTER THE WORK AREA

IMMEDIATELY LEAVE THE WORK AREA AND REMOVE THE RESPIRATOR IF ANY OF THE FOLLOWING OCCUR:

- The flow of air ceases or decreases.
- You feel ill (nauseous, dizzy, hot or cold)
- You feel breathless or have difficulty breathing.
- Any component in the respirator assembly becomes damaged.
- The pressure at the point of attachment dips below that recommended.
- You can see, smell or taste contaminants inside the respirator.
- You cannot see clearly

rpb[®] T100 SERIES

NV2016 - ADJUSTING THE FLOW RATE

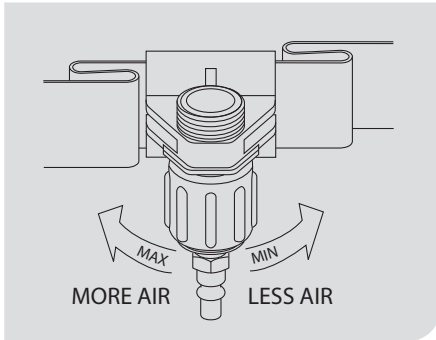

Air flowing into the respirator is controlled by the NV2016 as shown in the illustration to the left.

Note: With the pressure set according to the Breathing Air Pressure Table the flow rate of air through the respirator should always exceed the minimum of 170 l/min.

4000-40 - ADJUSTING THE TEMPERATURE

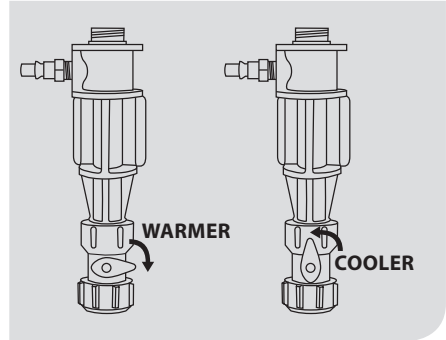

To obtain cooler air turn the regulator control knob anticlockwise so it is aligned along the length of the tube. This will increase the air flow out of the exhaust port. Similarly, turn the knob clockwise 90°, this will increase the temperature of the air closer to the ambient temperature of your air supply.

!WARNING! Do not use the 4000-40 when ambient temperature is below 68° (20°C) as ice could form in the cold air outlet resulting in insufficient airflow.

DOFFING YOUR RESPIRATOR

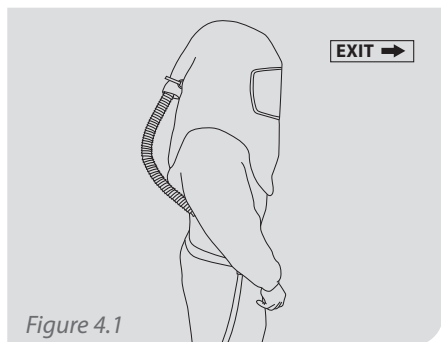

Leave Work Area

Leave the work area while still wearing the respirator. The air must be flowing into the respirator until you have departed from the contaminated area. Once in a clean environment, undo the belt and remove the respirator.

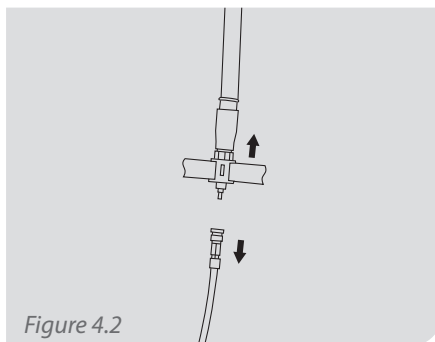

Disconnect Air Supply

It is now safe to disconnect the air supply hose using the quick disconnect coupler.

BREATHING TUBE ASSEMBLY

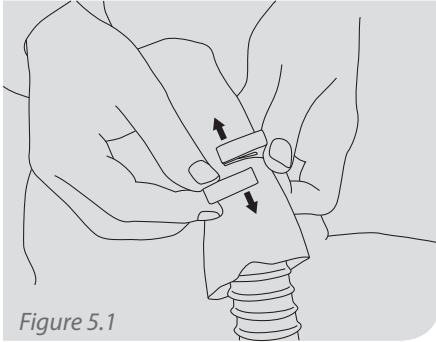

Remove Hose Clamp

Release the hose clamp by sliding the locks sideways in opposite directions.

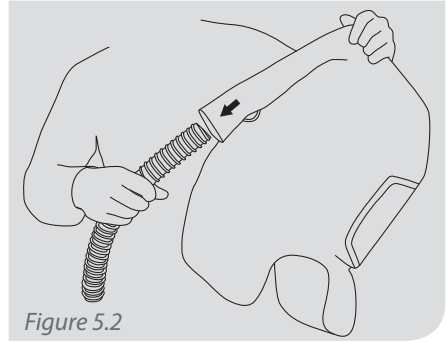

Detach Tube From Respirator

Remove the Breathing Tube from the respirator

!WARNING! Air Leaks will cause a drop in air flow resulting in less protection.

AIR SUPPLY HOSES

Inspect the Air Supply Hose for cuts, cracks, blisters and excessive wear. Ensure the hose has not been crushed or kinked and that fittings are tightly crimped to the hose so air cannot escape. Replace the hose immediately if there are any signs of damage or wear. Do not run water through the inside of the hose. Check Quick Disconnect Couplings and use compressed air to remove any particles that may jam the coupler.

STORAGE

After the respirator and the components have been inspected and cleaned, place them in an air tight container, or plastic bag. Store Respirator parts away from contaminants, direct sunlight, heat, extreme cold, moisture, or harmful chemicals.

INSPECTION, CLEANING & STORAGE

The T100 has a limited service life, and therefore a regular inspection and replacement program must be conducted. All components of this Respirator Assembly including the Air Supply Hoses should be inspected for damage and wear and tear, before use. If any damaged or worn parts are found, they should be replaced immediately, or the Respirator disposed of. Use only parts and components that are part of the NIOSH approved respirator assembly as set out in this instruction manual. Refer to the parts list on page 18-19 for the correct part numbers.

RESPIRATOR

- Inspect the material for rips, tears, or damage including loose or missing threads, that may reduce the protection of the respirator .
- Inspect the lenses for cracks, scratches, or distortions that may reduce the clarity or protection of the lens. Do not wipe the lens with strong solvents, as they may damage, or distort the lens.
- Inspect the inner bib for elasticity and to ensure that there are no tears, missing treads, or other damage.
- If any part is damaged, replace them with parts and components that are part of the NIOSH approved respirator assembly only, or dispose of the respirator, and replace it with a new one.
- Cleaning the Respirator is not recommended. When the Respirator becomes dirty, it should be replaced or disposed of.

HEAD SUSPENSION AND HARD HAT

- Remove the Head Suspension or Hard Hat from the Respirator. Inspect for cracks, worn adjustment slots, or broken parts. Any parts that are damaged or worn must be replaced immediately.
- The brow pad can be removed, and cleaned in a conventional washing machine, or be rinsed with a light detergent and water. Do not clean with volatile chemicals.

rpb® T100 SERIES

PARTS LIST

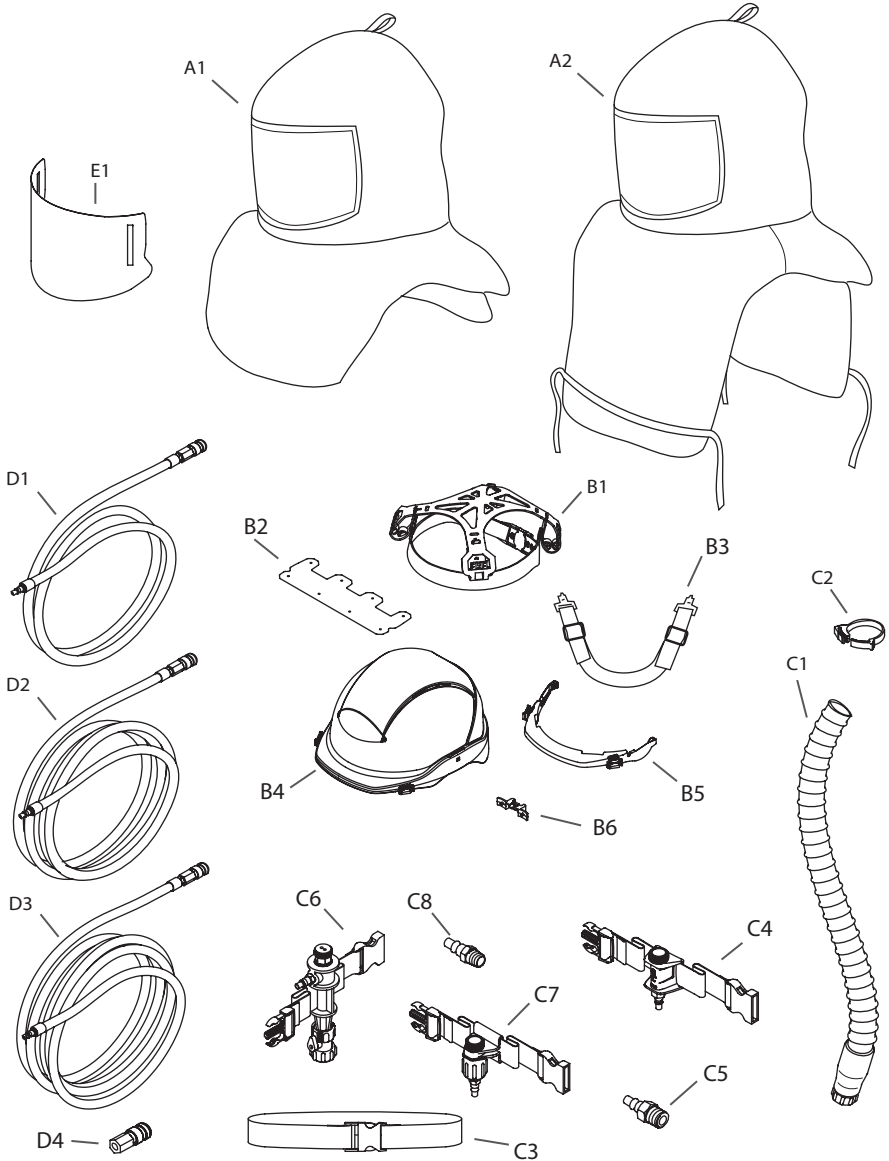

Item	Description	Part Number
A1	Respirator Hood with Regular Bib	07-110
	Respirator Hood with Regular Bib and Safety Lens	07-110-S
	Respirator Hood SL Fabric, Sealed Seams and Regular Bib	07-150
	Respirator Hood SL Fabric, Sealed Seams, Regular Bib and Safety Lens	07-150-S
A2	Respirator Hood with Extra Length Bib	07-110-X
	Respirator Hood with Extra Length Bib and Safety Lens	07-110-SX
	Respirator Hood SL Fabric, Sealed Seams and Extra Length Bib	07-150-X
	Respirator Hood SL Fabric, Sealed Seams, Extra Length Bib and Safety Lens	07-150-SX
B1	Head Suspension	07-920
B2	Head Suspension Brow Pad (Pkt. of 5)	07-924
B3	Optional Chin Strap	07-926
B4	Hard Hat (Incl. 07-125)	07-126
B5	Hard Hat, Clip Adapter	07-125
B6	Head Suspension Mount	07-121
C1	Breathing Tube	NV 2021F
C2	Hose Clamp for Breathing Tube	07-122
C3	Replacement Belt	NV 2022
C4	Constant Flow Valve	03-101
C5	Quick Disconnect Tail, 3/8" NPT	03-111
C6	Cold Air Tube (Silenced)	4000-40
C7	Flow Control Valve	NV2016
C8	Quick Disconnect Tail, 1/4" BSPT	4000-06
D1	Air Supply Hose 25ft	NV 2028
D2	Air Supply Hose 50ft	NV 2029
D3	Air Supply Hose 100ft	NV 2027
D4	Quick Disconnect Coupler, 1/4" BSP	NV 2025
E1	Peel-off Lenses (Pkt. of 50)	07-123

Tychem® is a registered trademark of E.I. du Pont de Nemours and Company.
 RPB® is a registered trademark of RPB Limited.

rpb® T100 SERIES

NEW & REPLACEMENT T100 RESPIRATORS

Part Numbers	Replacement Hoods								Material Specification		Lens Protection		Bib Style		Head Gear		Air Flow Device		
	07-110	07-110-S	07-110-X	07-110-SX	07-150	07-150-S	07-150-X	07-150-SX	Tychem OC	Tychem SL	Normal (0.020)	Safety (0.040)	Regular	Extra Length	Head Suspension	Hard Hat	03-101 Constant Flow	NV2016 Flow Control	4000-40 Cool Air Tube
07-101	✓							✓		✓		✓		✓			✓		
07-102	✓							✓		✓		✓		✓				✓	
07-103	✓							✓		✓		✓		✓					✓
07-101-S		✓						✓			✓	✓		✓					
07-102-S		✓						✓			✓	✓		✓					
07-103-S		✓						✓			✓	✓		✓					
07-101-X			✓					✓		✓			✓	✓			✓		
07-102-X			✓					✓		✓			✓	✓				✓	
07-103-X			✓					✓		✓			✓	✓					✓
07-101-SX				✓				✓			✓		✓	✓			✓		
07-102-SX				✓				✓			✓		✓	✓				✓	
07-103-SX				✓				✓			✓		✓	✓					✓
07-151					✓				✓	✓		✓		✓			✓		
07-152					✓				✓	✓		✓		✓				✓	
07-153					✓				✓	✓		✓		✓					✓
07-151-S						✓			✓		✓	✓		✓			✓		
07-152-S						✓			✓		✓	✓		✓				✓	
07-153-S						✓			✓		✓	✓		✓					✓
07-151-X							✓		✓	✓			✓	✓			✓		
07-152-X							✓		✓	✓			✓	✓				✓	
07-153-X							✓		✓	✓			✓	✓					✓
07-151-SX								✓	✓		✓		✓	✓			✓		
07-152-SX								✓	✓		✓		✓	✓				✓	
07-153-SX								✓	✓		✓		✓	✓					✓

Part Numbers	Replacement Hoods								Material Specification		Lens Protection		Bib Style		Head Gear		Air Flow Device		
	07-110	07-110-S	07-110-X	07-110-SX	07-150	07-150-S	07-150-X	07-150-SX	Tychem OC	Tychem SL	Normal (0.020)	Safety (0.040)	Regular	Extra Length	Head Suspension	Hard Hat	03-101 Constant Flow	NV2016 Flow Control	4000-40 Cool Air Tube
07-201	✓								✓		✓		✓			✓	✓		
07-202	✓								✓		✓		✓			✓		✓	
07-203	✓								✓				✓			✓			✓
07-201-S		✓							✓			✓	✓			✓			
07-202-S		✓							✓			✓	✓			✓			
07-203-S		✓							✓			✓	✓			✓			
07-201-X			✓						✓		✓			✓		✓			
07-202-X			✓						✓		✓			✓		✓		✓	
07-203-X			✓						✓		✓			✓		✓			✓
07-201-SX				✓					✓			✓		✓		✓			
07-202-SX				✓					✓			✓		✓		✓		✓	
07-203-SX				✓					✓			✓		✓		✓			✓
07-251					✓					✓	✓		✓			✓	✓		
07-252					✓					✓	✓		✓			✓		✓	
07-253					✓					✓	✓		✓			✓			✓
07-251-S						✓				✓		✓	✓			✓		✓	
07-252-S						✓				✓		✓	✓			✓		✓	
07-253-S						✓				✓		✓	✓			✓			✓
07-251-X							✓			✓	✓			✓		✓		✓	
07-252-X							✓			✓	✓			✓		✓		✓	
07-253-X							✓			✓	✓			✓		✓			✓
07-251-SX								✓		✓		✓		✓		✓		✓	
07-252-SX								✓		✓		✓		✓		✓		✓	
07-253-SX								✓		✓		✓		✓		✓		✓	

OTHER PRODUCTS

ISO9001
CERTIFIED COMPANY

AIRLINE FILTRATION

The RPB® RADEX AIRLINE FILTER™ offers increased capacity, versatility and filtration. This optional equipment combines the versatility of either floor or wall mounting with increased filtration capacity, enabling customization to meet worker's needs and working environments.



AIR TEMPERATURE CONTROL

The RPB® 4000-01 Cool Air Tube cools compressed breathing air coming into the respirator by up to 30°F while the RPB® 4000-20 Hot Air Tube will heat the compressed air by up to 30°F. These maximize worker comfort and increase productivity in hot or cold climates.



AIR QUALITY MONITORING

The RPB® RADEX CO MONITOR™ helps ensure worker safety with a unique traceability feature that monitors and records carbon monoxide levels, and temperature. This data that provides certainty of monitor functioning and can be stored for up to two years allowing analysis of plant and field air quality.



1 866 494 4599
www.rpbsafety.com

rpb®
ADVANCING
YOUR SAFETY