



ANSAC

Contact Us

ANSAC TECHNOLOGY (S) PTE LTD
 35, Marsiling Industrial Estate Road 3,
 #02-01 Singapore 739257
 +65 6368 0225 | sales@ansac-tech.com.sg
www.ansac-tech.com.sg



BW4003A Series Bottled Water System

FOR HOME AND COMMERCIAL APPLIANCES

Genuine Singflo bottled water system is ideal where portability is key

Pump recipe-quality water from commercial bottles to ensure better-tasting hot and cold beverages. The new BW4003A Bottled Water System is designed to work with coffee/tea makers, refrigerator ice and water dispensers, espresso carts and portable sinks or any use requiring portable potable water.

The BW4003A Bottled Water System is also designed for convenience. The pump automatically shuts off when the water source is depleted and restarts when water is restored. Its compact size supports easy mounting.



Features and Benefits

- 💧 New Ergonomic T-Shaped Wand Handle: Allows for ease of installation and removal of wand from bottle
- 💧 Universal seal cap fits most water containers
- 💧 Compact size for easy mounting
- 💧 Long-Life Motor: Ensures years of reliable operation
- 💧 Quiet Operation: Minimizes noise pollution with noise-dampening rubber feet
- 💧 Singflo Diaphragm Pump: Runs dry without damage, extending pump life
- 💧 Quick Connect Port :Speeds installation and replacement of suction and discharge tubing

Bottled Water System Plus

For Home and Commercial Application



Applications

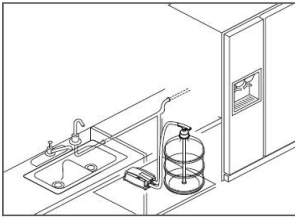

Refrigerator Dispense

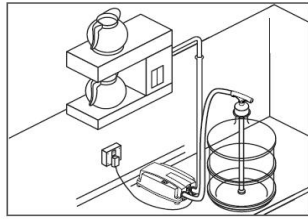

Coffee Maker Dispense

- 💧 Tea/Coffee Machines
- 💧 Beverage Kiosks
- 💧 Water Dispensers
- 💧 Ice Makers
- 💧 Refrigerators
- 💧 Anywhere Portable potable water is Needed

Specification

Max. Pressure	40PSI (2.76 bar)
Dimensions	2.95"H x 5.12"W x 7.62"D (74.93mmH x 130.05mmW x 193.54mm D)
Voltages	115VAC to 230V AC
Flow rate	1GPM (3.8Lpm)
Pressure	40psi (2.8bar)
Amps Draw	0.5A
Cycle	50/60 Hz for AC models
Weight	5.72lbs.(2.60kg)

Model	Voltage	Power adapter type
BW4003A	115V to 230V	US/AU/UK/EU plug

Dimensional Drawing

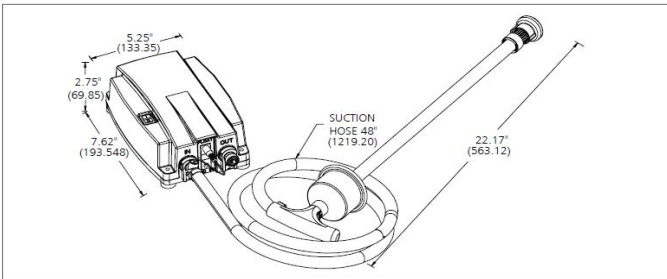

Wall Power Transformer

* Also available in EU, UK and AU power adapters.

Includes

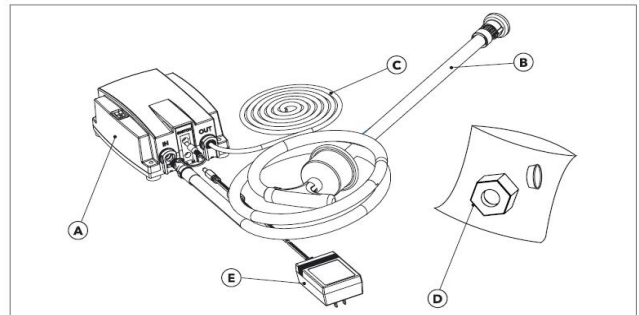

- A. Main module with On/Off rocker switch
- B. Suction Wand and Hose Assembly
- C. Discharge Tube 20 ft(6.1m) 1/4 in.(6.35mm) OD
- D. Compression nut and sleeve
- E. Wall power transformer

SINGFLO BW Series BOTTLED WATER DISPENSER SYSTEM



Singflo Single Inlet BW Series

At just 6" x 8" the Singflo Inlet Bottled water dispensing System is the most compact system you can buy and it's the most affordable.

- * Float Switch for Automatic Shut-off
- * Built-in Check Valve
- * Universal Seal Cap.
- * Easy Mounting
- * Upgrade Kits are Available
- * 20'(6.1m)0.250"(0.5cm)OD discharge hose included

TYPICAL INSTALLATIONS

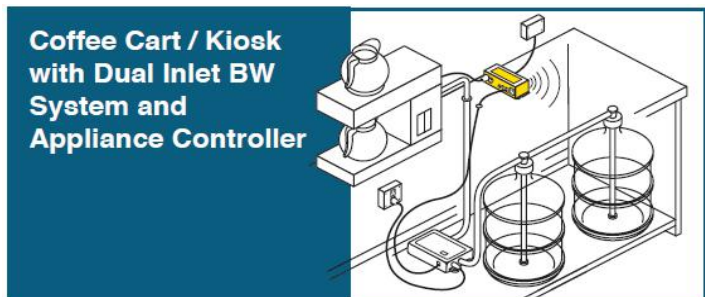
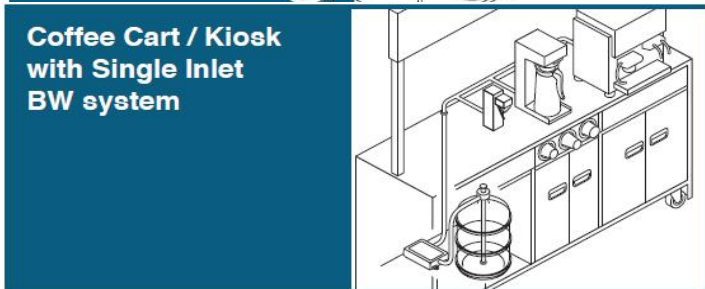
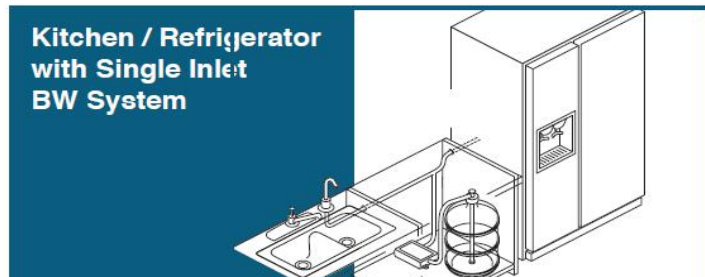

SPECIFICATION

Voltage	115 VAC & 230VAC,12VDC
Cycle	50/60 Hz.for AC Models
Current	
115 VAC	0.50 Amps. Max.
230 VAC	0.25 Amps.Max.
12 VDC	3.0 Amps.Max.
Max.Flow	1.0GPM (3.8L/min)
Max.Pressure	40psi (2.8 bar)
Housing Material:	ABS
Shipping Weight	6.4lbs.(2.9kg)

DIMENSIONS

Control Box	3.0 in.H x 5.5in.W x 7.5 in.D (76.0mm x 140.0mmx190.0mm)
-------------	---

MODEL NUMBERS

Single inlet

BW1000A	115VAC	6 feet cord with plug
BW2000A	230VAC	6 feet cord with plug
BW3000A	12 VDC	12 in.(30cm)lead wires

Dual Inlet

BW1020A	115VAC	3.5ft (1m)cord with plug
BW2020A	230VAC	3.5ft(1m)cord with plug
BW6004A	230VAC	3.5ft(1m)cord with plug

APPLICATION

- 💧 Tea/Coffee Machines
- 💧 Beverage Kiosks
- 💧 Water Dispensers
- 💧 Ice Makers
- 💧 Refrigerators
- 💧 Anywhere Portable potable water is Needed



Singflo Simple Shower water pump for outdoor Camping

Application: This pump is designed for simple outdoor shower, washdown usage.

Singflo pump included:

- *Shower with hose
- *Pump Module with ON/Off switch
- *Filter
- *Line with cigarett Lighter

Feature:

1. With the cigarette lighter,can link with your car battery easily
2. Pressure switch for auto shut-off when don't use it
3. Built-in check valve to prevent back flow
4. Universal seal cap fits most water containers
5. Compact size for easy mounting
6. Long life motor : Ensures years of reliable operation
7. Easy installed/

Specifications:

Max.flow rate:1.0GPM (3.8lpm)

Max.Pressure: 40psi (2.8bar)

Dimensions: 39*25.5*11cm

Voltage:12v DC

Amp Draw:3.0Amps.Max

Weight:2.9kgs (5.6 net lbs)

Technical datas:

Model	GPM/LPM	Max.PSI	Outlet	Volts	Amps	Dimensions	Weight
BW50A	1.0/3.8	40PSI	1/4"	12	3A	39/25.5*11cm	3.5KGS

