

OM

SERIES

Quarter-turn
Electric Valve Actuators

Service Unique Nice Youthful Energy Honesty

SUNYEH

OPERATION MANUAL



SUN YEH ELECTRICAL IND. CO., LTD.

SY01-C001F-EN

Contents

1.	General Information.....	1
1.1	Safety Instructions.....	1
1.2	Installation Notices.....	1
1.3	Inspection, Storage, Transport.....	2
2.	Product Overview	3
2.1	Features	3
3.	Product Mechanical Data.....	4
3.1	Parts Identification	4
3.2	Technical Information	4
3.3	Mounting Base Details.....	5
3.4	Sizing.....	6
3.5	Duty Cycle	6
4.	Mounting and Setup.....	7
4.1	Manual Device Installation (OM-2 to 13, OM-F, OM-G, OM-H and OM-J).....	7
4.2	Valve Mounting Instructions	8
4.3	Wiring Instructions.....	9
4.4	Actuator Set-up	10
5.	Torque Switch (Optional)	16
5.1	Instructions.....	16
6.	Modulating Control Board Adjustment	17
6.1	Modulating Control Board (OM-1, OM-A, OM-AM).....	17
6.2	Modulating Control Board (OM-2 ~ OM-13、OM-F、OM-G、OM-H)	23
6.3	Modulating Board with MODBUS Function (Optional Item).....	31
7.	Troubleshooting	44
8.	Warranty	47
9.	Disposal	47

1. General Information

⚠ Failure to follow safety instructions may cause serious injury, equipment damage, or voided warranty.

1.1 Safety Instructions

- Installation, maintenance and repair works must be performed by trained personnel.
- The handling shall follow the safety and warning instruction contained in this manual.
- The user should read and follow instructions contained in this operation manual included with the product. Failure to do this may result in damages and void warranty. Sun Yeh will not be liable for damages due to operator negligence or misuse.
- Local health and safety legislation shall be complied with.
- In a few cases, the surface temperature may exceed 60 °C (140 °F). Please check the surface temperature before operation, using an appropriate thermometer and wearing protective gloves before operation.

1.2 Installation Notices

⚠ Before operating a three-phase voltage actuator, please manually operate it to mid-travel position by the handwheel and power up to check if it rotates properly in order to verify the phase sequence is correct. If it is incorrect, please correct the phase errors by changing the connection of any two of power supply wires U, V, W to prevent the actuator from mechanical damages.

⚠ Operating by handwheel :
Do not use any tools to increase force on handwheel for operating as this can damage the actuator or valve.

- Please read operation manual and wiring diagram carefully before installation.
- Verify that supply voltage is in accordance with the data on nameplate to prevent short circuit or electrical/electronic parts damage caused by incorrect power input.
- Turn power off before wiring or maintenance.
- Connect the ground wire to PE point inside the electric actuator.
- To avoid functional failure caused by static, do not touch any components on the PCB with metal tools or bare hands.
- Do not parallel wire multiple actuators together without using an extra relay or equipping with Isolation Relay Module.
- Use suitable water-proof cable gland to ensure it fits the conduit entry size, diameter of the cable and the enclosure protection of the actuator when wiring. The water-proof cable gland must be tightened and flattened to the cable after wiring procedure and use proper water-proof plug to seal unused conduit entry and fasten the top cover of the actuator to prevent dust or water from entering the actuator. The red plastic dust-proof plug is not meant for long-term use. Replace it with suitable water-proof connector to ensure the enclosure protection rating.

- Actuator should be installed in an upright or horizontal position. Do not mount upside down or below a horizontal position.
- These units are not designed to operate in vacuum spaces or where an explosive atmosphere exists.
- Periodically inspect actuator enclosure to prevent dust from accumulating.

1.3 Inspection, Storage, Transport

1.3.1 Receiving / Inspection

- Carefully inspect the package for any damages resulting from shipping and report all damages to the freight carrier and seller.
- After unpacking the product and information packet, please keep the cartons and any packing materials in case of product return or replacement. Verify that the items on the packing slip or on the bill of lading are the same as what were ordered. If there is any discrepancy, please contact the seller.
- Verify if the technical data on nameplate is accordance with what was ordered.

1.3.2 Storage

- The actuator should be stored in a dry area with relative humidity of less than 90 % (20 ± 5 °C) and at temperatures between -20 °C to +40 °C (-4 °F to +104 °F).
- The product shall be stored with suitable protection from corrosive substance that can damage the metal and insulating parts.
- The red conduit plug for temporary protection should not be removed until the actuator is ready to be cabled. Use suitable cable glands with IP protection when installing.

1.3.3 Transport

- Attach ropes or hooks for the purpose of lifting by hoist only to housing and not to handwheel.
- Actuators packaged in cartons can stand up to land, sea, or air transportation.
- Packaged actuators shall avoid of violent impact and strong vibrations and be protected from rain or snow.

1.3.4 Lubrication

- The gear train has been sufficiently lubricated at the factory. No additional lubrication is required.

2. Product Overview

OM series quarter-turn electric actuators offer torque ranges from 35 N·m to 4,500 N·m (310 in·lb to 40,000 in·lb). These actuators come standard with a C3, NEMA 4X, 5 & IP67 enclosure for outdoor use. All models are ISO 5211 compliant and equipped with a continuous mechanical position indicator and manual override (except BM-2 and OM-A). The manual override can be operated without clutch and brake.

2.1 Features

- High alloy-steel gear trains with self-locking prevent back-drive.
- Clutch-less manual override.
- Dry-powder coated aluminum alloy enclosure conforms to C3, NEMA 4X, 5 & IP 67 outdoor use.
- ISO 5211 mounting flange.
- Mechanical end stops.
- Domed position indicator.
- Built-in motor thermal protection.

3. Product Mechanical Data

3.1 Parts Identification



3.2 Technical Information

Model	Torque		Weight		Motor Power	Manual Override	Flange Type
	N·m	in·lb	kg	lb	Watt		ISO 5211
OM-1	35	310	2	4.4	10	Lever	F03 / F05
OM-A	50	445	3	6.6	10	N/A	F05 / F07
OM-AM	50	445	3	6.6	10	Lever	F05 / F07
OM-F	65	575	11	24.3	60	Handwheel	F07 / F10
OM-J	80	708	3	6.6	5	Lever	F05 / F07
OM-2	90	800	10.5	23.1	40	Handwheel	F07 / F10
BM-2	120	1065	5.5	12.1	40	N/A	F07
OM-G	120	1065	11	24.3	60	Handwheel	F07/F10
							F07 / F10
OM-3	150	1330	10.5	23.1	40		F07 / F10
OM-H	300	2655	15	33.1	60		F07 / F10
OM-4	400	3540	20	44.1	80		F10 / F12
OM-5	500	4430	20	44.1	80		F10 / F12
OM-6	650	5755	20	44.1	80		F10 / F12
OM-7	1000	8855	36	79.4	120		F12 or F14
OM-8	1500	13280	36	79.4	120		F12 or F14
OM-9	2000	17710	68.5	151	180		F14 or F16
OM-10	2500	22140	68.5	151	180		F14 or F16
OM-11	3000	26565	68.5	151	180		F14 or F16
OM-12	3500	31000	68.5	151	220		F14 or F16
OM-13	4500	40000	102.5	226	220	F16 / F25	

3.3 Mounting Base Details

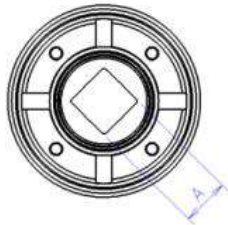
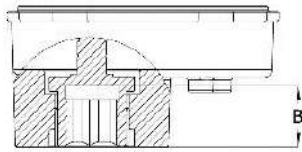

【BM-2】

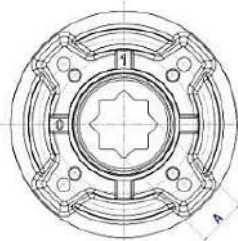
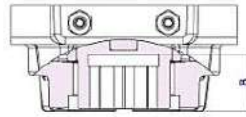

【OM-A, OM-AM, OM-F, OM-G, OM-H, OM-J and OM-1 to OM-6】

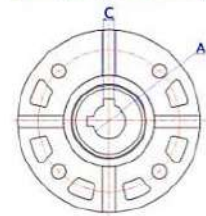
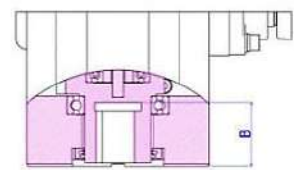

【OM-7 to OM-13】

Model	Flange Type	Shaft (A)		Depth of Shaft (B)		Key (C)	
		mm	inch	mm	inch	mm	inch
OM-1	F03 / F05	14	0.551	17	0.669	-	-
OM-A	F05 / F07	17	0.669	20	0.787	-	-
OM-AM,OM-J	F05 / F07	17	0.669	20	0.787	-	-
OM-F,OM-G	F07 / F10	22	0.886	30	1.181	-	-
OM-2 to OM-3	F07 / F10	22	0.886	30	1.181	-	-
BM-2	F07	22	0.886	35	1.377	-	-
OM-H	F07 / F10	22	0.886	30	1.181	-	-
OM-4 to OM-6	F10 / F12	36	1.417	40	1.574	-	-
OM-7 to OM-8	F12 or F14	35	1.377	60	2.362	10 × 10	0.393×0.393
OM-9 to OM-12	F14 or F16	75	2.952	100	3.937	12 × 10	0.472×0.393
OM-13	F16 / F25	72	2.834	110	4.33	20 × 12	0.787×0.472

3.4 Sizing

- a. The actuator shall be sized to ensure that its torque output meets the load requirements of valve and its ability to overcome the required duty cycle of application (As a MINIMUM, a 30% safety factor is suggested for the calculation of torque requirement).

- If the maximum torque of 5" valve is 80 N·m → 80 × 1.3 (safety factor) = 104N·m
104 N·m < 150 N·m (OM-3) →OK!
 104 N·m > 90 N·m (OM-2) →Not OK!

- b. In cases where the actuator does not fit directly onto the valve, a mounting kit is required. Please ensure the bracket and coupling are properly designed and manufactured to withstand the torque output of the actuator.

3.5 Duty Cycle

- The standard duty cycle for OM series is 30% and 50% or 75% is for option. The duty cycle is the relationship between the running time and resting time. It is calculated as below:

$$\text{Duty Cycle} = \frac{\text{Running Time (Sec)}}{\text{Running Time (Sec)} + \text{Rest Time (Sec)}} \times 100 \%$$

$$\Rightarrow \text{Rest Time (Sec)} = \frac{\text{Running Time (Sec)} \times (1 - \text{Duty Cycle})}{\text{Duty Cycle}}$$

- **If the running time for OM-2 is 15 sec, 30% duty cycle, the rest (off) time shall be calculated as below:**

$$\rightarrow 15 \times [(1 - 30\%) / 30\%] = 35 \text{ The rest time will be 35 sec.}$$

- **If the running time for OM-2 is 15 sec, 75% duty cycle, the rest (off) time shall be calculated as below:**

$$\rightarrow 15 \times [(1 - 75\%) / 75\%] = 5 \text{ The rest time will be 5 sec.}$$

Note: For higher duty cycles, choose the 75% duty cycle.

⚠ One cycle consists of open-rest-close-rest.

4. Mounting and Setup

4.1 Manual Device Installation (OM-2 to 13, OM-F, OM-G, OM-H and OM-J)

- a. Pass the screw through the handle and tighten the nut onto handwheel.

⚠ Do not overtighten.

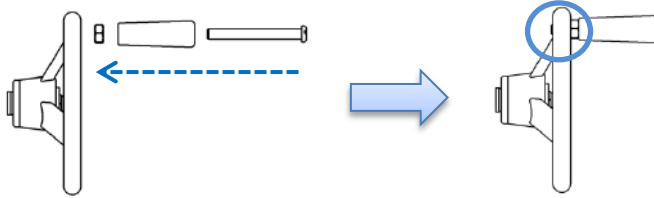

- b. Secure the handle to the wheel with the slotted screw and tighten the locknut all the way down to the wheel. Ensure that the locknut is locked between the wheel and the handle.

⚠ Leave a 2mm gap between the locknut and the handle as the figure below to allow the handle free to rotate and then to have a smooth manual operation.

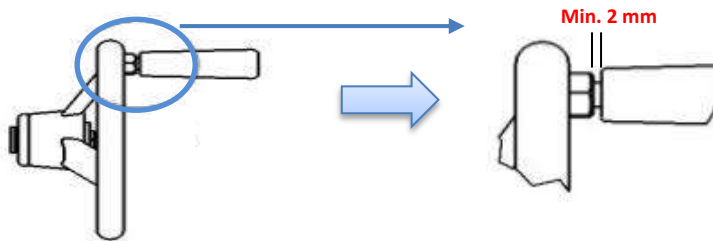

- c. Slide fixing screw through washers and handwheel and secure them to override shaft as shown in the figure below.

⚠ Turn off power when installing handwheel.

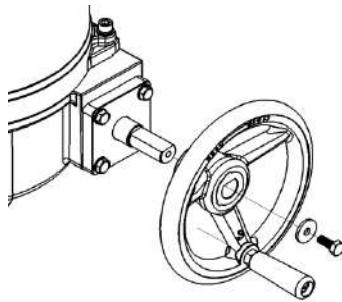

- d. Assembly completed as shown in the figure below.

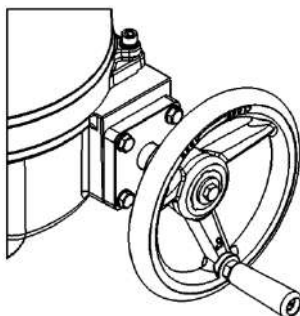

OM-1, OM-AM & OM-J

OM-1

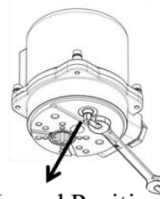

Manual Position

Use a 8mm wrench to rotate the shaft.
Max. torque : 5 N·m

OM-AM , OM-J

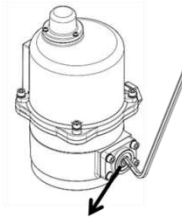

Manual Position

Use a 5mm wrench to rotate the shaft.
Max. torque : 5 N·m

4.2 Valve Mounting Instructions

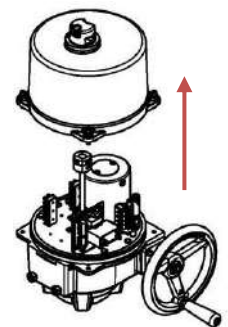

- a. Make sure both the valve and actuator are in the same position before mounting, either fully-open or fully-closed. If not, use the manual override to correct this.
- b. Once mounted together, either directly or with a mounting kit, ensure that they are properly secured together and all fasteners are tightened.
 - ⚠ **Remove all of valve handle parts, for example, the handle or open / close mechanical stops so as to not interfere with the actuator.**
- c. Check again that the valve and actuator are in the same position.
- d. Remove the conduit entry plug to relieve the pressure inside the actuator for the ease of the top cover removal and gently remove the cover.
 - ⚠ **The power must be off before removing the cover.**
- e. Refer to section 4.3 (P.9) for wiring instructions and connect the wires according to the wiring diagram labeled inside the cover of actuator.
 - ⚠ **Before operating a three-phase voltage actuator, please manually operate it to mid-travel position by the handwheel and power up to check if it rotates properly in order to verify the phase sequence is correct. If it is incorrect, please correct the phase errors by changing the connection of any two of power supply wires U, V, W to prevent the actuator from mechanical damages.**
- f. Supply power to actuator.
 - ⚠ **Care must be taken at all times as there are live circuits present that may cause electrical shock.**
- g. Re-calibration may be required for the end positions, refer to 4.4 (P.10) for further instructions.
- h. For modulating units, refer to 6 (P.17 - P.43) setting instructions.
 - ⚠ **Use the insulated wires and length should be less than 30 m.**
 - ⚠ **A minimum of 18 AWG wire is recommended for all field wiring.**
 - ⚠ **Turn power off before changing any settings.**
- i. Assemble the cover and secure cover screws firmly after setting.
 - ⚠ **Please ensure that the O-ring seal is in good condition prior to cover installation.**





Handwheel

4.3 Wiring Instructions

 **Turn power off before making the electrical connection!**

- Connect the ground wire to PE point placed on middle metal plate inside the electric actuator (a green screw).
- Each actuator is attached with a black water-proof plug and a temporary red dust-proof plug to conduit entries.
 -  **Use correct size of fittings so as to not damage the threads.**
- Verify the supply power is in accordance with the data on the nameplate to prevent a short circuit and an electrical shock.
 -  **Do not apply power to actuator before wiring, otherwise it can cause an electrical shock or damage components of the actuator.**
- Use proper sealant to seal the conduit connection after wiring procedure to prevent dust or water from entering the actuator.
 -  **The red plastic dust-proof plug is not meant for long-term use. Replace it with suitable water-proof connector to ensure the enclosure protection rating.**

4.4 Actuator Set-up

-  **The power must be off during this procedure so as to avoid damage to the actuator.**
-  **Do not make adjustments to the mechanical end stops when actuator is in motion.**
-  **All steps below must be completed before normal operation.**

The actuators have been set and calibrated at the factory. Most of products will not require recalibration of these settings. However these are general settings. After valve and actuator are bolted together, apply power to verify the end positions are correct. If an adjustment is required, please follow steps below. When the actuator is equipped with modulating controller, signal setting for open and close position has to be re-set accordingly, please refer to 6.1.5 and 6.2.5.

4.4.1 Instructions

- The travel cams are set to control the open and closed position of the actuator. See below procedure for corresponding actuator model:
 - OM-1, OM-A and OM-AM : The position is set to stop the travel of the actuator when the travel cams activate the limit switch.
 - OM-2 to OM-13, OM-F, OM-G, OM-H and OM-J : The position is set to stop the travel of the actuator when the travel cams don't activate the limit switch.
- The standard is with two limit switches (LS1 & LS2) and cams (TC1 & TC2).
 - LS1 & LS2 : LS1 is for open and LS2 is for close. They limit the fully-open and fully-closed travel range by disabling the electric motor.
 - LS3 & LS4 are optional. They allow external equipment to confirm that the valve has reached the fully-open and fully-closed positions.

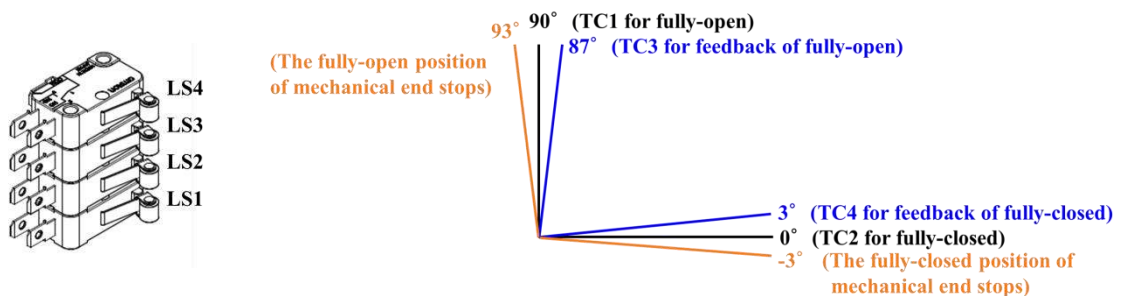

- Dry contact sequence diagram (LS3 & LS4)

【OM-1, OM-A, OM-AM】

Symbol	Contact	Position	
		100%	0%
LS4 (Dry Contact)	A - F	—————	-----
	A - E	-----	—————
LS3 (Dry Contact)	A - C	—————	-----
	A - B	-----	—————

【OM-2 to OM-13, OM-F, OM-G, OM-H】

Symbol	Contact	Position	
		100%	0%
LS4 (Dry Contact)	D - F	-----	—————
	D - E	—————	-----
LS3 (Dry Contact)	A - C	—————	-----
	A - B	-----	—————

【OM-J】

Symbol	Contact	Position	
		0%	100%
LS4 (Dry Contact)	A - E	-----	—————
	A - F	—————	-----
LS3 (Dry Contact)	A - B	—————	-----
	A - C	-----	—————

- Solid line (——) : Dry contact in conductive state.
- Dotted line (-----) : Dry contact in non-conductive state.

4.4.2 Adjustment Steps

- Turn power off.
- Loosen the locknut and unwind both Open and Close Mechanical end stop screws for 7 turns.

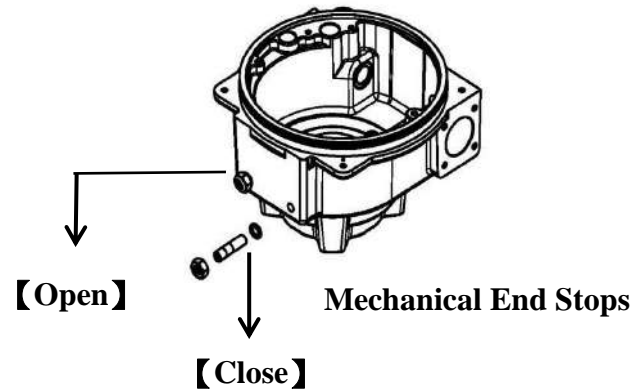

- When choosing modulating units or VR, loosen the M5 set screw on the sector gear or round gear.

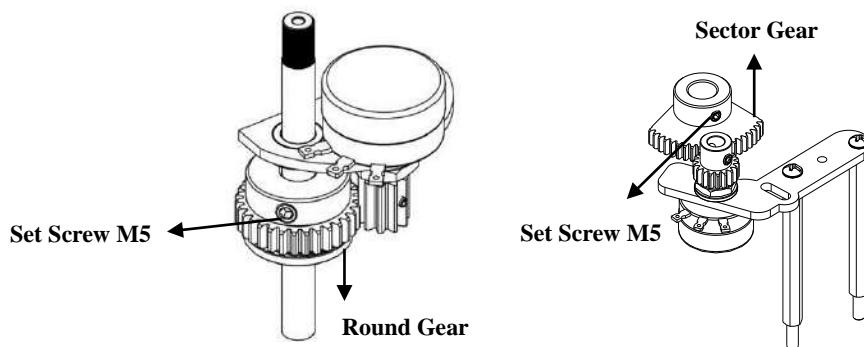

【OM-1, OM-A, OM-AM and OM-J】 【OM-2 to OM-13, OM-F, OM-G and OM-H】

- Adjust the **fully-open** position
 - ⚠ OM-A and BM-2 are not available for the manual device setting.**
 - 1. Use the manual override to turn the valve to fully-open position.
 - 2. Remove the cover.
 - OM-1, OM-A and OM-AM : Loosen the M5 set screw of cam TC1 with a 2.5 mm Allen Key.
 - OM-2 to OM-13, OM-F, OM-G and OM-H : Loosen the M3 set screw of cam TC1 with a 2.5 mm Allen Key.
 - OM-J : Loosen the M4 set screw of cam TC1 with a 2 mm Allen Key.
 - 3. Adjust the travel cam based on the corresponding actuator model below:
 - OM-A and OM-AM**
 - Rotate the cam TC1 **clockwise** to contact the switch arm.
 - Slowly rotate the cam TC1 **clockwise** until a light click is heard.
 - OM-1**
 - Rotate the cam TC1 **counter-clockwise** to contact the switch arm.
 - Slowly rotate the cam TC1 **counter-clockwise** until a light click is heard.

OM-2 to OM-13, OM-F, OM-G and OM-H

- Rotate the cam TC1 **counter-clockwise** to contact the switch arm.
- Slowly rotate the cam TC1 **counter-clockwise** until a light click is heard.

OM-J

- Rotate the cam TC1 **clockwise** to contact the switch arm.
- Slowly rotate the cam TC1 **clockwise** until a light click is heard.

4. Securely tighten the M5 / M4 / M3 set screw and apply power to check if the fully-open position is correct. If it is not correct, please repeat steps 1 to 3.
5. Use the same method to reset the cam TC3.

 **Adjust cam TC3 so it trips just before cam TC1 does.**

6. After the adjustment is completed, check again that the M5 set screw is securely tightened.

e. Adjust the **fully- closed** position

1. Use the manual override to turn the valve to fully-closed position.
2. OM-1, OM-A and OM-AM: Loosen the M5 set screw of cam TC2 with a 2.5 mm Allen key.

OM-2 to OM-13, OM-F, OM-G and OM-H: Loosen the M3 set screw of cam TC2 with a 2.5 mm Allen Key.

OM-J: Loosen the M4 set screw of cam TC2 with a 2 mm Allen Key.

3. Adjust the travel cam based on the corresponding actuator model below:

OM-A and OM-AM

- Rotate the cam TC2 **counter-clockwise** to contact the switch arm.
- Slowly rotate the cam TC2 **counter-clockwise** until a light click is heard.

OM-1

- Rotate the cam TC2 **clockwise** to contact the switch arm.
- Slowly rotate the cam TC2 **clockwise** until a light click is heard.

OM-2 to OM-13, OM-F, OM-G and OM-H

- Rotate the cam TC2 **clockwise** to contact the switch arm.
- Slowly rotate the cam TC2 **clockwise** until a light click is heard.

OM-J

- Rotate the cam TC2 **counter-clockwise** to contact the switch arm.
- Slowly rotate the cam TC2 **counter-clockwise** until a light click is heard.

4. Securely tighten the M5 / M4 / M3 set screw and apply power to check if the fully-closed position is correct. If it is not correct, please repeat steps 1 to 3.





5. Use the same method to reset the cam TC4.

 **Adjust cam TC4 so it trips just before cam TC2 does.**

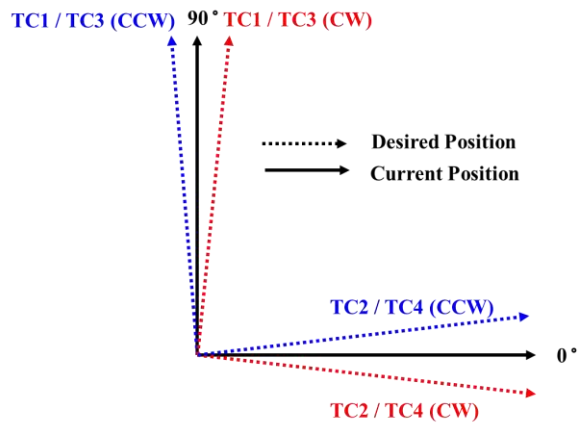
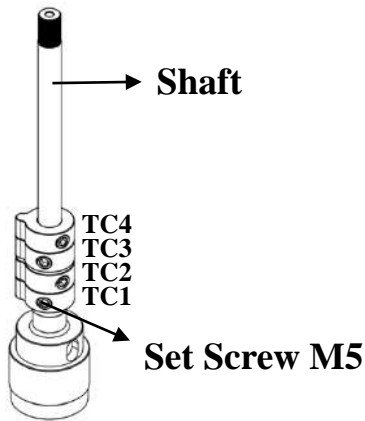
6. After the adjustment is completed, check again that the M5 set screw is securely tightened.





OM-A and OM-AM

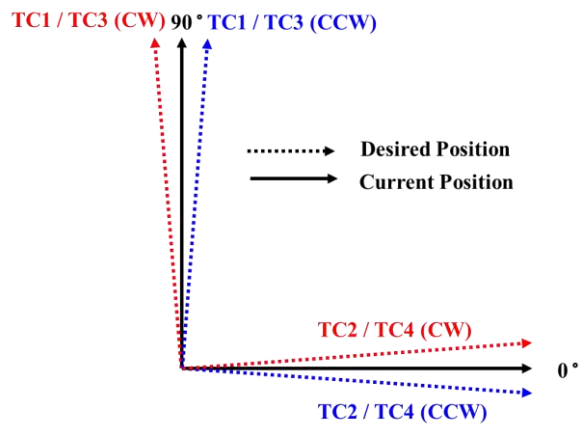
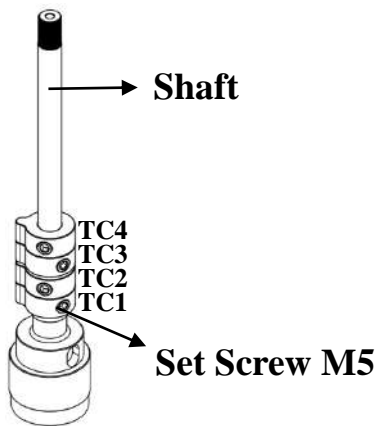

- | | | |
|---------------------|---|---|
| TC2 “CLOSE” |  | Clockwise: increase closing degree. |
| TC4 (Optional Item) |  | Counter-clockwise: decrease closing degree. |
| TC1 “OPEN” |  | Clockwise: decrease opening degree. |
| TC3 (Optional Item) |  | Counter-clockwise: increase opening degree. |

OM-1





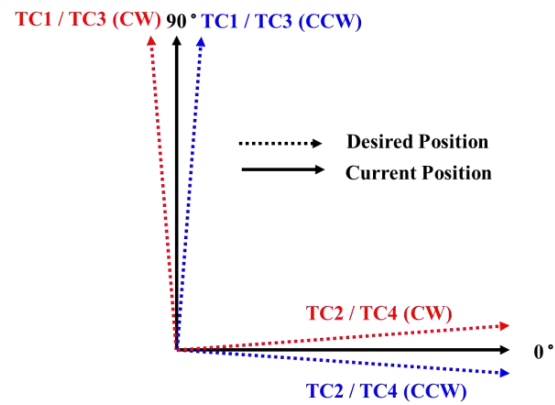
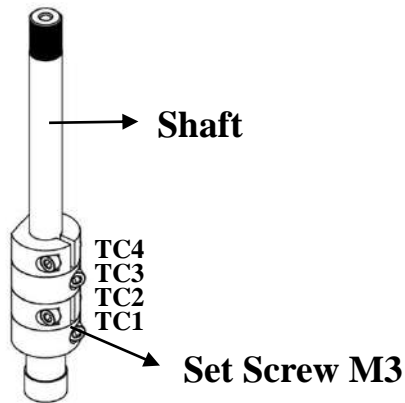

- | | | |
|---------------------|---|---|
| TC2 “CLOSE” |  | Clockwise: decrease closing degree. |
| TC4 (Optional Item) |  | Counter-clockwise: increase closing degree. |
| TC1 “OPEN” |  | Clockwise: increase opening degree |
| TC3 (Optional Item) |  | Counter-clockwise: decrease opening degree. |

【OM Series】 Quarter -Turn Electric Valve Actuator





OM-2 to OM-13, OM-F, OM-G and OM-H

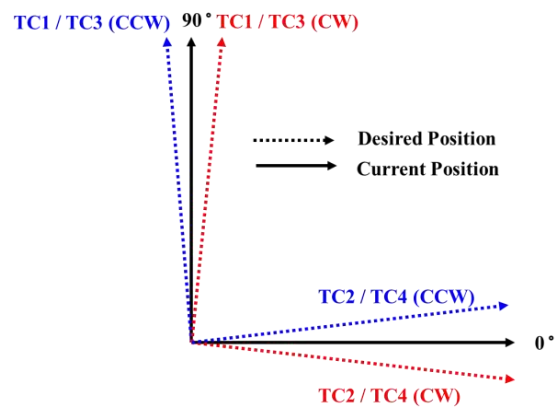
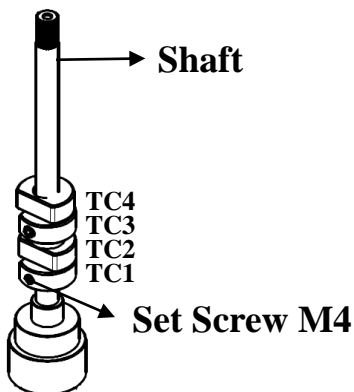

- | | | |
|---------------------|---|---|
| TC2 “CLOSE” |  | Clockwise: decrease closing degree. |
| TC4 (Optional Item) |  | Counter-clockwise: increase closing degree. |
| TC1 “ OPEN” |  | Clockwise: increase opening degree |
| TC3 (Optional Item) |  | Counter-clockwise: decrease opening degree. |

OM-J



- | | | |
|---------------------|---|---|
| TC2 “CLOSE” |  | Clockwise: increase closing degree. |
| TC4 (Optional Item) |  | Counter-clockwise: decrease closing degree. |
| TC1 “ OPEN” |  | Clockwise: decrease opening degree. |
| TC3 (Optional Item) |  | Counter-clockwise: increase opening degree. |

【OM Series】Quarter -Turn Electric Valve Actuator

- f. Supply power to the fully-open position. Screw in the Open (left) Mechanical end stop screw until it bottoms out (refer to P.11 4.4.2), then turn back for 1/2-1 turn based on the actuator model listed below.
 - OM-2 to OM-6, OM-F, OM-G and OM-H : 1 turn
 - OM-7 to OM-8 : 3/4 turn
 - OM-9 to OM-13 : 1/2 turn
- g. Tighten the locknut. (Max. Torque : 5.88 N·m)
- h. Supply power to the fully-open position. Screw in the Open (right) Mechanical end stop screw until it bottoms out (refer to P.11 4.4.2), then turn back for 1/2-1 turn based on the actuator model listed below.
 - OM-2 to OM-6, OM-F, OM-G and OM-H : 1 turn
 - OM-7 to OM-8 : 3/4 turn
 - OM-9 to OM-13 : 1/2 turn
- i. Tighten the locknut. (Max. Torque : 5.88 N·m)
- j. Supply the power to confirm that the limit switches achieve the fully open-close stroke.
- k. When choosing modulating units or VR:
Supply power to run the actuator to the fully-closed position. Adjust the gear and the set screws based on the actuator model listed below.

OM-A,OM-AM and OM-J	Rotate the round gear counter-clockwise to the end and tighten the M5 set screw.
OM-1	Rotate the round gear clockwise to the end and tighten the M5 set screw.
OM-2 to OM-13 OM-F, OM-G and OM-H	Rotate the sector gear clockwise to the end and tighten the M5 set screw.

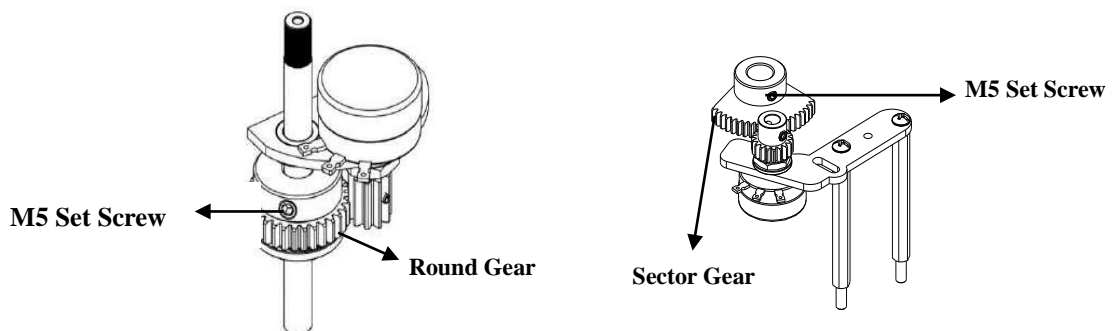

【OM-1, OM-A, OM-AM and OM-J】 【OM-2 to OM-13, OM-F, OM-G and OM-H】

1. The setting procedure is now completed.

5. Torque Switch (Optional)

5.1 Instructions

- The optional is with two torque switches (TS1 & TS2) and cams (TC1 & TC2). TS3 & TS4 can be added as feedback dry contacts.
 TS1 & TS2: TS1 is for open and TS2 is for close. They torque switch the open and closed travel range by provides torque overload protection.
 TS3 & TS4 are optional. They allow external equipment to confirm that the valve has reached the torque limit value arbitrary.

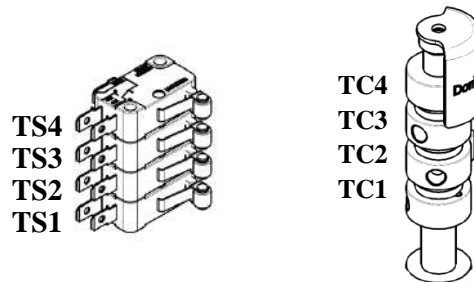

- Dry contact sequence diagram (TS3 & TS4)

Symbol	Contact	Torque	
		Overload (Open)	Overload (Close)
TS4 (Dry Contact)	COM-NC	—	- - - -
	COM-NO	- - - -	—
TS3 (Dry Contact)	COM-NC	- - - -	—
	COM-NO	—	- - - -

- Solid line (—): Dry contact in conductive state.
- Dotted line (- - - -): Dry contact in non-conductive state.

6. Modulating Control Board Adjustment

6.1 Modulating Control Board (OM-1, OM-A & OM-AM)

6.1.1 Surface

The layout is based on 110 / 220 V AC voltage.

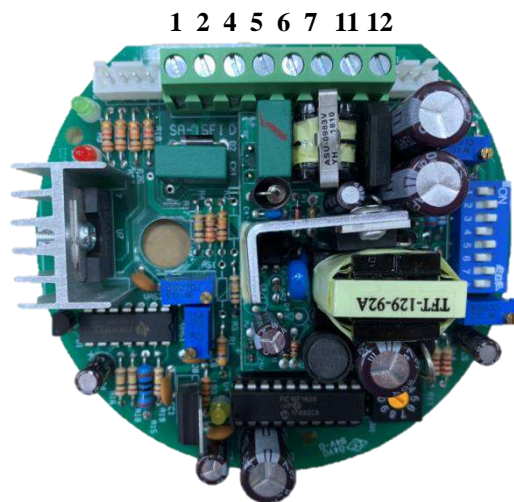

6.1.2 Programming

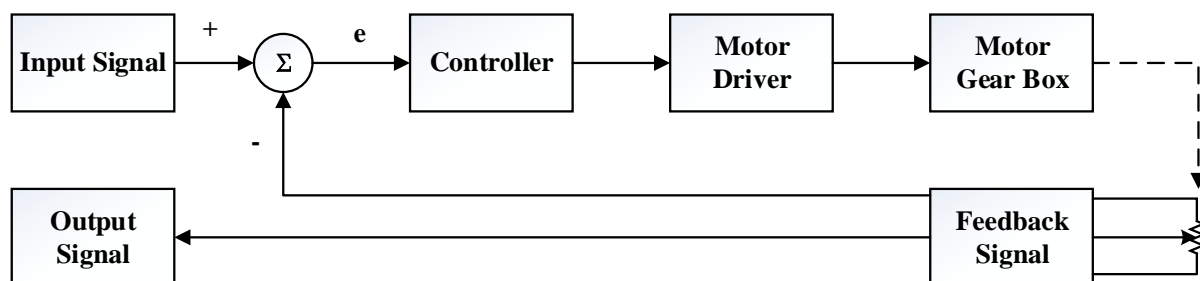

6.1.3 Dip Switch Setting (SW1)

The Dip Switch SW1 is a combination of 8 switches and equally divided in two rows. It is utilized to select signal type of input as well as output and fail positioning when the signal input fails. The sliders can be placed at either ON (upper) or OFF (lower) state position. Factory settings are switches 1, 4, 8 at ON state and switches 2, 3, 5, 6, 7 at OFF state.

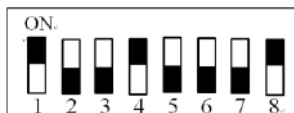

Please follow steps below if an adjustment of these settings are required.

⚠ Please restart the actuator after adjusting.

	1	2	3	4	5	6	7	8
Factory Setting	ON	OFF	OFF	ON	OFF	OFF	OFF	ON
4 - 20 mA input	ON	OFF						
1 - 5 V input	OFF	OFF						
2 - 10 V input	OFF	ON						
4 - 20 mA output			OFF	ON	OFF			
2 - 10 V output			ON	OFF	ON			
Input 20 mA / 5 V / 10 V to operate valve to fully-open position						OFF		
Input 20 mA / 5 V / 10 V to operate valve to fully-closed position						ON		
When signal input failed, driving valve to fully-open (when S6 sets at “ON”).							OFF	ON
When signal input failed, driving valve to fully-closed (when S6 sets at “ON”).							ON	OFF
When signal input failed, driving valve to fully-closed (when S6 sets at “OFF”).							OFF	ON
When signal input failed, driving valve to fully-open (when S6 sets at “OFF”).							ON	OFF
When signal input failed, valve stays at the last position.							ON	ON

a. Input signal setting (Switches 1 - 2)

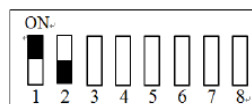

Input Signal	State of Switch
4 - 20 mA	1 at ON, 2 at OFF
1 - 5 V	1 at OFF, 2 at OFF
2 - 10 V	1 at OFF, 2 at ON

b. Output signal setting (Switches 3 - 5)

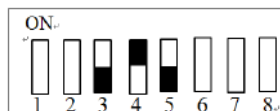

Output Signal	State of Switch
4 - 20 mA	3 at OFF, 4 at ON, 5 at OFF
2 - 10V	3 at ON, 4 at OFF, 5 at ON

c. Setting of fail position when input signal fails (Switches 6 - 8)

- ⚠ **The input signal type is set by switches 1 and 2. And switch 6 is used to set the corresponding relationship between the input signal value and the angle of the actuator.**
- ⚠ **If you require S6 to be set at ON and Clockwise to open, please specify in purchase order to modify the internal wiring during production; otherwise, the output signal will be opposite to the input signal.**

When S6 is set to ON

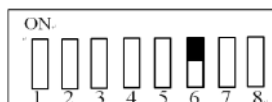

- The program defines 20 mA or 5 V or 10 V as a command for fully-closed positioning. The line graph below shows the signal level and the corresponding position of actuator.

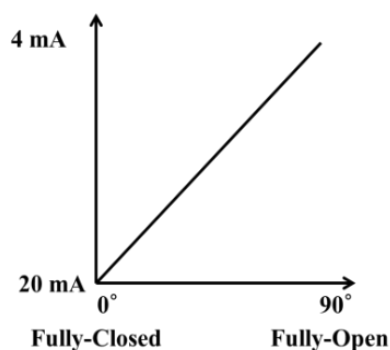

- When a low signal value is received, the actuator operates toward fully-open position and when a high signal value is received, the actuator operates toward fully-closed position.

Input Signal	Fully-Open (90°)	Fully-Closed (0°)
4 - 20 mA	4 mA	20 mA
1 - 5 V	1 V	5 V
2 - 10 V	2 V	10 V

【OM Series】 Quarter -Turn Electric Valve Actuator

- The selection of the fail position while the input signal failed, please follow table below:

Signal Failed Position	State of Switch
Fully-Open (90°)	7 at OFF, 8 at ON
Fully-Closed (0°)	7 at ON, 8 at OFF
The Last Position	7 at ON, 8 at ON

When S6 is set to **OFF**



- The program defines 20 mA / 5 V / 10 V as a command for fully-open positioning. The line graph below shows the signal level and the corresponding position of the actuator.

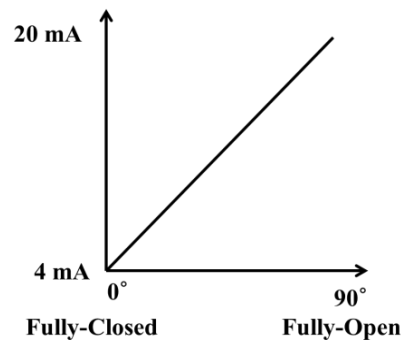

- When a high signal value received, the actuator operates toward fully-open position and when a low signal value received, the actuator operates toward fully-closed position.

Input Signal	Fully-Open (90°)	Fully-Closed (0°)
4 - 20 mA	20 mA	4 mA
1 - 5 V	5 V	1 V
2 - 10 V	10 V	2 V

- The selection of the fail position while the input signal failed, please follow table below:

Signal Failed Position	State of Switch
Fully-Open (90°)	7 at ON, 8 at OFF
Fully-Closed (0°)	7 at OFF, 8 at ON
The Last Position	7 at ON, 8 at ON

6.1.4 Sensitivity Switch Setting (SW2)

When the sensitivity setting is higher, the resolution of the input signal will be higher, and relatively the dead band will be smaller. Excessive high sensitivity setting may cause the actuator to keep hunting and could not run to the desired position which will lead to the thermostat inside the motor to trip because of overheating, and finally the actuator will shut down. If this situation happens, it is suggested to turn down the sensitivity setting.

a. Setting

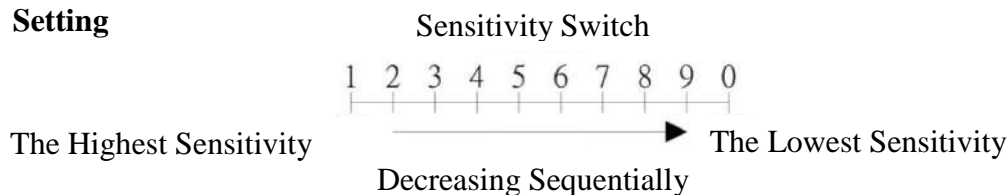

- When switched to “1”: The Highest Sensitivity.
- When switched to “0”: The Lowest Sensitivity.

b. Original Factory Setting

- OM-1, OM-A & OM-AM : 3



6.1.5 Signal Setting for Open and Close Position

- ⚠ **These settings are set and calibrated at the factory. Be sure to reset the Signal Setting for Open and Close Position when recalibrating TC1 and TC2 for fully-open and fully-closed position or other signal types are required.**
- ⚠ **Use a multimeter to measure the output signal in accordance with the selected signal type.**
 - VR1, VR51, VR2 and VR52 are used to adjust signal input as well as output.

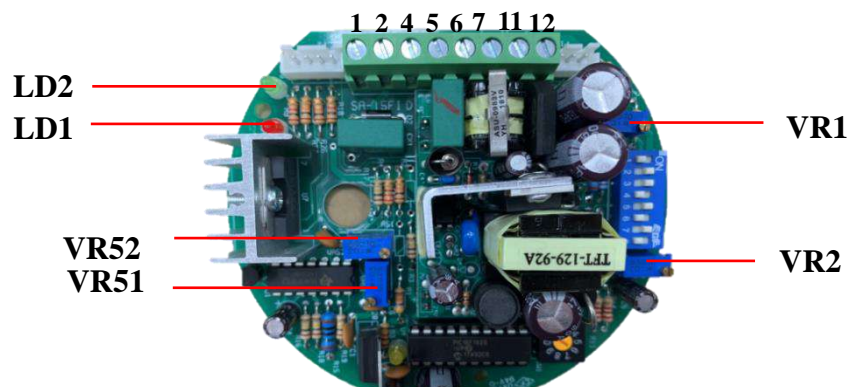

Variable Resistor	Signal type to be adjusted	Position to be adjusted
VR1	To adjust 5 V, 10 V, 20 mA input signal	Fully-Open
VR51	To adjust 10 V, 20 mA output signal	Fully-Open
VR2	To adjust 1 V, 2 V, 4 mA input signal	Fully-Closed
VR52	To adjust 2 V, 4 mA output signal	Fully-Closed

Lamp	Status
LD1	Fully-closed
LD2	Fully-open

- ⚠ **If VR51 and VR52 are adjusted, VR1 and VR2 must be adjusted accordingly.**

- **Signal setting for Fully-OPEN position**

Rotate **VR1** counter-clockwise until a light click is heard, then apply 5 V, 10V or 20mA to the modulating board. After that, slightly rotate **VR1** clockwise until the LD2 goes on and then adjust **VR51** to complete the setting. When adjusting **VR51**, if the LD2 is off, keep rotating **VR1** clockwise until the LD2 goes on.

VR51 ↻ Clockwise: decreasing signal value.
 ↺ Counter-clockwise: increasing signal value.

- **Signal setting for Fully-CLOSED position**

Rotate **VR2** clockwise until a light click is heard, then apply 1 V, 2 V or 4 mA to the modulating board. After that, slightly rotate **VR2** counter-clockwise until the LD1 goes on and then adjust **VR52** to complete the setting. When adjusting **VR52**, if the LD1 is off, keep rotating **VR2** counter-clockwise until the LD1 goes on.

VR52 ↻ Clockwise: decreasing signal value.
 ↺ Counter-clockwise: increasing signal value.

After completing the above settings, press “SET” button to quit local setting.

6.2 Modulating Control Board (OM-2 to OM-13, OM-F, OM-G & OM-H)

6.2.1 Surface

The layout is based on 110 / 220 V AC voltage.

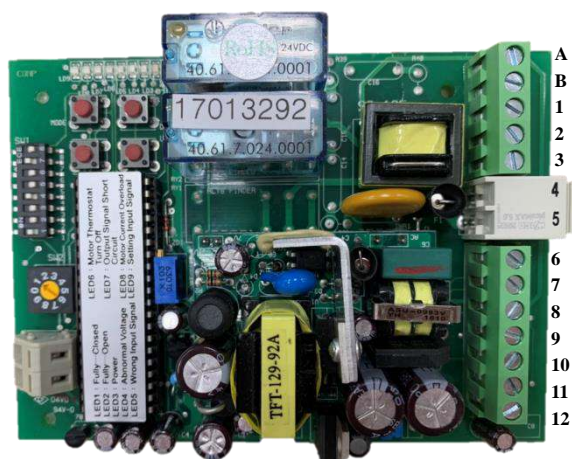

6.2.2 Programming

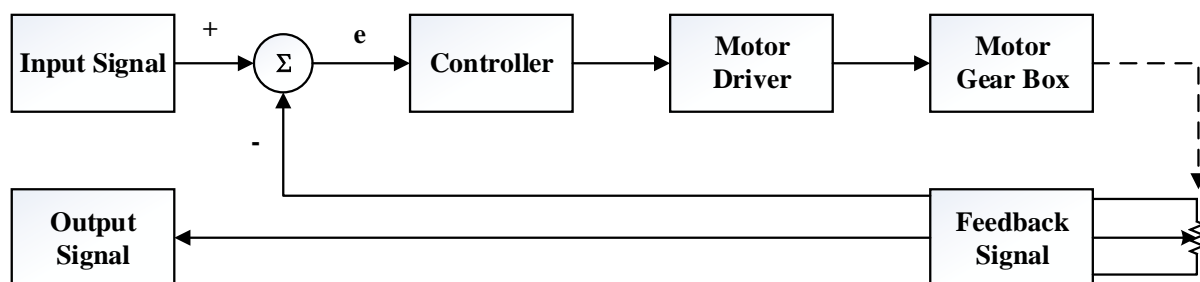

6.2.3 Dip Switch Setting (SW1)

The Dip Switch SW1 is a combination of 8 switches and equally divided in two rows. It is utilized to select signal type of input as well as output and fail positioning when the signal input fails. The sliders can be placed at either ON (upper) or OFF (lower) state position. Factory settings are switches 1, 4, 8 at ON state and switches 2, 3, 5, 6, 7 at OFF state.

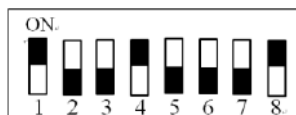

	1	2	3	4	5	6	7	8
Factory Setting	ON	OFF	OFF	ON	OFF	OFF	OFF	ON
4 - 20 mA input	ON	OFF						
1 - 5 V input	OFF	OFF						
2 - 10 V input	OFF	ON						
4 - 20 mA output			OFF	ON	OFF			
2 - 10 V output			ON	OFF	ON			
Closed direction setting: CW						OFF		
Closed direction setting: CCW						ON		
When signal input failed, driving valve to fully-open							ON	OFF
When signal input failed, driving valve to fully-closed							OFF	ON
When signal input failed, valve stays at the last position							ON	ON
							OFF	OFF

a. Input signal setting (Switches 1 - 2)

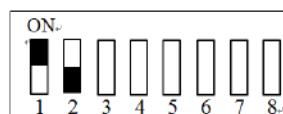

Input Signal	State of Switch
4 - 20 mA	1 at ON, 2 at OFF
1 - 5 V	1 at OFF, 2 at OFF
2 - 10 V	1 at OFF, 2 at ON

【OM Series】 Quarter -Turn Electric Valve Actuator

b. Output signal setting (Switches 3 - 5)

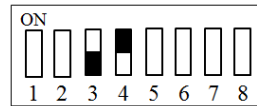

- Output signal can be fine-tuned by VR2.
- When resetting the Output Signal, be sure to fine-tune VR2 to match the setting either 2 - 10 V or 4 - 20 mA.

Output Signal	State of Switch
4 - 20 mA	3 at OFF, 4 at ON, 5 at OFF
2 - 10 V	3 at ON, 4 at OFF, 5 at ON

c. Close direction setting (switch 6)

- When S6 is set to OFF, the close direction is CW (clockwise).
 - When S6 is set to ON, the close direction is CCW (counterclockwise).
- ⚠ The input signal type is set by switches 1 and 2. And switch 6 is used to set the corresponding relationship between value of input signal and operation direction of actuator as shown in the figure below, e.g., 4 - 20 mA input signal.**
- ⚠ The operating direction of the actuator has been set and calibrated at the factory. Be sure to change the direction of the position indicator if different operating direction is required.**

When S6 is set to **OFF**

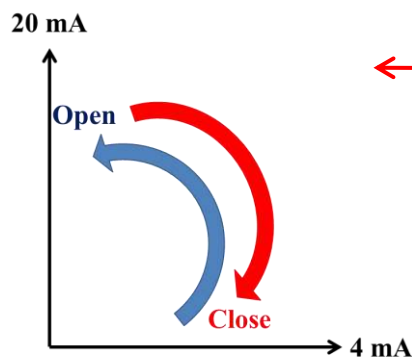

Position Indicator (Fully-Open→Fully-Closed)	Operating Position	Input Signal	LED	Output Signal
CW	Fully-Closed	1 V, 2 V, 4 mA	LD1 ON	2 V, 4 mA
	Fully-Open	5 V, 10 V, 20 mA	LD2 ON	10 V, 20 mA

【OM Series】 Quarter -Turn Electric Valve Actuator

When S6 is set to **ON**

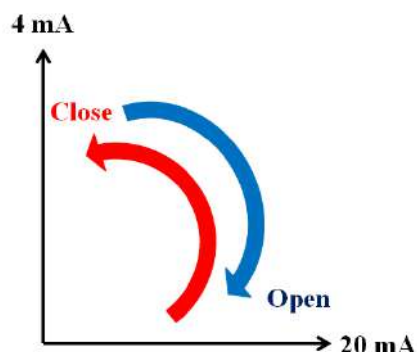
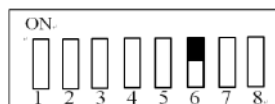

Position Indicator (Fully-Open→Fully-Closed)	Operating Position	Input Signal	LED	Output Signal
CCW	Fully-Closed	1 V, 2 V, 4 mA	LD1 ON	2 V, 4 mA
	Fully-Open	5 V, 10 V, 20 mA	LD2 ON	10 V, 20 mA

d. Failed position setting while the input signal failed. (switches 7 and 8)

- When a low signal value is received, the actuator operates toward fully-open position and when a high signal value is received, the actuator operates toward fully-open position.

Input Signal	Fully-Open	Fully-Closed
4 - 20 mA	4 mA	20 mA
1 - 5 V	1 V	5 V
2 - 10 V	2 V	10 V

- The selection of the fail position while the input signal failed, please follow table below:

Signal Failed Position	State of Switch
Fully-Open	7 at ON, 8 at OFF
Fully-Closed	7 at OFF, 8 at ON
The Last Position	7 at ON, 8 at ON 7 at OFF, 8 at OFF

6.2.4 Sensitivity Switch Setting (SW2)

When the value of sensitivity (%) is lower, the resolution of the input signal will be higher, and relatively the dead band will be smaller. Excessive high resolution may cause the actuator to keep hunting and could not run to the desired position which will lead to the thermostat inside the motor to trip because of overheating, and finally the actuator will shut down. If this situation happens, it is suggested to adjust the sensitivity setting.

a. Setting

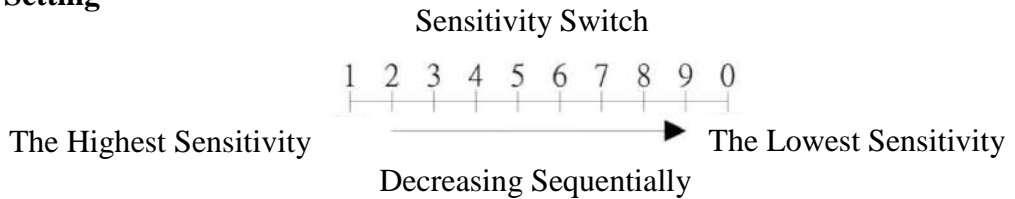

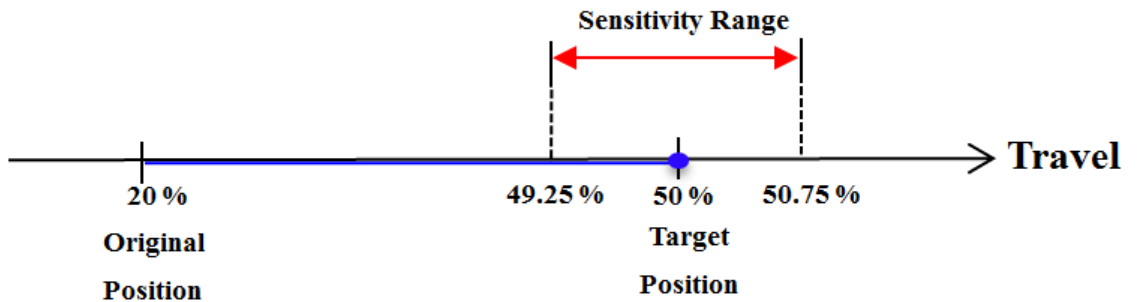

Setting Value	1	2	3	4	5	6	7	8	9	0
Sensitivity (%)	0.25	0.5	0.75	1	1.25	1.5	1.75	2	2.25	2.5

- When switched to “1”: The Highest Sensitivity.
- When switched to “0”: The Lowest Sensitivity.
- For example: When the sensitivity switch is set to “3” (0.75%) and the target position is 50%, the valid sensitivity range will be from 49.25% to 50.75% (50% ± 0.75%) as shown in the figure below.



b. Original Factory Setting

- OM-2 to OM-13, OM-H : 3
- OM-F, OM-G : 0

Model	Figure
OM-2 to OM-13, OM-H	
OM-F, OM-G	

6.2.5 Signal Setting for Open and Close Position

- ⚠ **These settings are set and calibrated at the factory. Be sure to reset the Signal Setting for Open and Close Position when recalibrating TC1 and TC2 for fully-open and fully-closed position or other signal types are required.**
- ⚠ **Use a multimeter to measure the output signal in accordance with the selected signal type.**
 - Using UP, DN, MODE, SET buttons to set the open and close position.

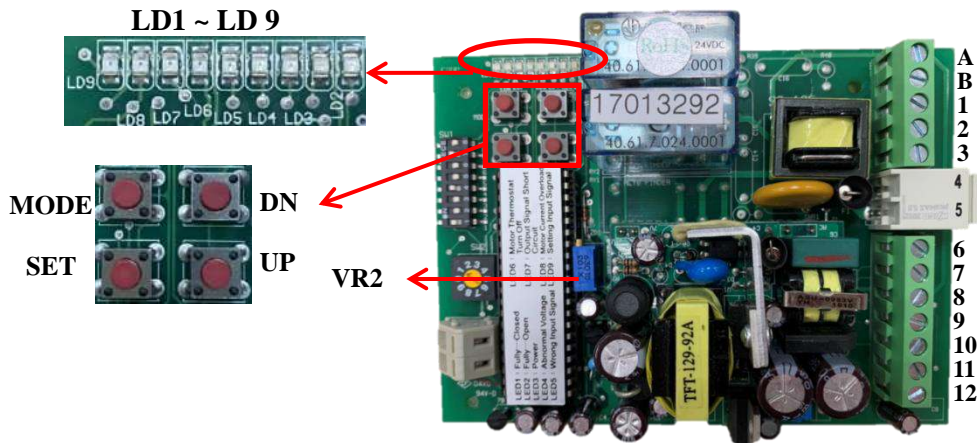

Lamp	Status	Lamp	Status
LD1	Fully-closed	LD6	Motor thermal protector activated.
LD2	Fully-open	LD7	Output signal short circuit
LD3	Power	LD8	Overcurrent in motor
LD4	Abnormal input voltage	LD9	Local setting mode
LD5	Wrong input signal		

Press and hold "SET" button for 2 seconds until LD 9 lights to enter local setting mode.

- **Signal setting for Fully-OPEN position**
 - a. Press and hold "UP" button to operate the actuator to open until it has reached fully-open position and LD2 lights and then input a signal 5 V or 10 V or 20 mA.
 - b. Press "MODE" button for 2 seconds until LD2 flashes to complete the setting of fully-open position.
- **Signal setting for Fully-CLOSED position**
 - a. Press and hold "DN" button to operate the actuator to close until it has reached fully-closed position and LD1 lights and then input a signal 1 V or 2 V or 4 mA.
 - b. Press "MODE" button for 2 seconds until LD1 flashes to complete the setting of fully-closed position.

ⓘ See below description for VR2 adjustment:

VR2 Clockwise: decreasing signal value.
 Counter-clockwise: increasing signal value.

After completing the above settings, press "SET" button to quit local setting

6.2.6 Troubleshooting of Modulating Controller

(OM-2 to OM-13, OM-F, OM-G & OM-H)

- ⚠ In case LD3 does not light or any of LD4 to LD9 lights when the actuator is motorized, please refer to steps below for basic troubleshooting.**
- ⚠ Please do the troubleshooting when LD4 to LD8 lights, and then restart the power to turn the lights off.**

Status of LEDs	Possible problems	Solution
LD3 does not go on	a. No power supplied. b. Modulating controller failed.	a. Check the power supply as well as wires connected to terminals #4 & #5, please refer to 6.2 (P.23) b. Send back to factory for inspection.
LD4 goes on (for 24V units)	The voltage is under 19.8 V DC.	Verify that the input voltage is within the allowable voltage deviation.
LD5 goes on	a. An incorrect signal type inputted. For example, preset with 2-10 V input but input 4-20 mA. b. Input a voltage exceeding the rated. For example, preset with 2-10 V input but input 13.5V. c. An incorrect signal type inputted. For example, preset with 4 - 20 mA input but input 2 - 10V. In this case, the actuator still works in 2 - 7V. When the signal is over 7.2 V, the LD5 lights.	Verify if the switch 1 is set in accordance with the type of input signal. Please refer to 6.2.3 (P.26 - P.29).
LD6 goes on	Motor thermal protector started.	a. The duty cycle exceeded the rated, please refer to 3.5 (P.6). b. The contact of motor thermal protector (MOT) disconnected.

【OM Series】 Quarter -Turn Electric Valve Actuator

Status of LEDs	Possible problems	Solution
LD7 goes on	<ul style="list-style-type: none"> a. Signal output short circuits. b. Both DIP switch #3 and #4 are set at ON or OFF. 	<ul style="list-style-type: none"> a. Verify if the signal output with reversed polarity. The negative pole should be connected to terminal #11 and the positive pole should be connected to terminal #12. b. Reset the dip switches per actual output signal. Please refer to 6.2.3. (P.24 - P.26)
LD8 goes on	Motor over-current.	<ul style="list-style-type: none"> a. Duty cycle exceeded the rated, please refer to 3.5 (P.6) and reduce the duty rating. b. Check the load. c. Check if the motor rotor is locked (For example: Valve is stuck by foreign objects).
LD9 goes on	Local setting mode - Setting position for open & close.	After completing the settings, press “SET” button to quit.

6.3 Modulating Board with MODBUS Function (Optional Item)

6.3.1 Surface

The layout is based on 110 / 220 V AC voltage.

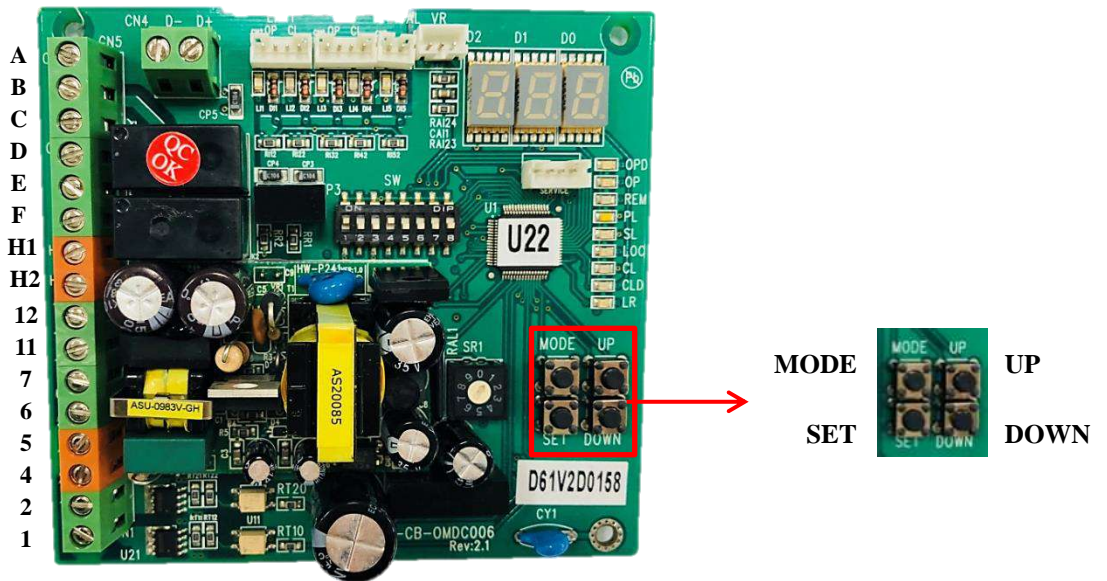

OM-A, OM-AM, OM-1



OM-2 to OM-13, OM-F, OM-G, OM-H
Duty Cycle 30%



OM-2 to OM-13, OM-F, OM-G, OM-H
Duty Cycle 75%

6.3.2 Dip Switch Setting (SW)

The Dip Switch SW is a combination of 8 switches and equally divided in two rows. It is utilized to select signal type of input as well as output and fail positioning when the signal input fails. The sliders can be placed at either ON (upper) or OFF (lower) state position.

Please follow steps below if an adjustment of these settings are required.

- ⚠ **Please restart the actuator after adjusting.**
- ⚠ **Modbus and Modulating Control could not be used at the same time.**

	1	2	3	4	5	6	7	8
MODBUS	ON	ON	OFF	OFF	OFF	OFF	OFF	OFF
4 - 20 mA input	ON	OFF						
1 - 5 V input	OFF	OFF						
2 - 10 V input	OFF	ON						
4 - 20 mA output			OFF	ON	OFF			
2 - 10 V output			ON	OFF	ON			
Input 20 mA / 5 V / 10 V to operate valve to fully-open position.						OFF		
Input 20 mA / 5 V / 10 V to operate valve to fully-closed position						ON		
When signal input failed, driving valve to fully-open (when S6 is set at “ ON”).							OFF	ON
When signal input failed, driving valve to fully-closed (when S6 is set at “ ON”).							ON	OFF
When signal input failed, driving valve to fully-closed (when S6 is set at “ OFF”).							OFF	ON
When signal input failed, driving valve to fully-open (when S6 is set at “ OFF”).							ON	OFF
When signal input failed, valve stays at the last position.							ON	ON

● **MOBUS:**

Set switches 1, 2 at ON state and switches 3, 4, 5, 6, 7, 8 at OFF state.

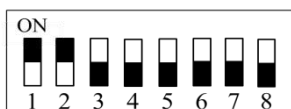

● **Modulating Control:**

Set switches 1, 4, 8 at ON state and switches 2, 3, 5, 6, 7 at OFF state.

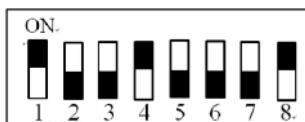

【OM Series】 Quarter -Turn Electric Valve Actuator

To enable Analog Modulation :

a. Input Signal Setting (switches 1 - 2)

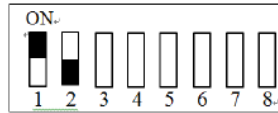

Input Signal	State of Switch
4 - 20 mA	1 at ON, 2 at OFF
1 - 5 V	1 at OFF, 2 at OFF
2 - 10 V	1 at OFF, 2 at ON

b. Input Signal Setting (switches 3 - 5)

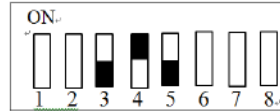

Output Signal	State of Switch
4 - 20 mA	3 at OFF, 4 at ON, 5 at OFF
2 - 10 V	3 at ON, 4 at OFF, 5 at ON

c. Setting of fail position when input signal fails (Switches 6 - 8)

⚠ The input signal type is set by switches 1 and 2. And switch 6 is used to set the corresponding relationship between value of input signal and operation direction of actuator.

When S6 is set to ON



- The program defines 20 mA / 5 V / 10 V as a command for **fully-closed** positioning. The line graph below shows the signal level and the corresponding position of the actuator.

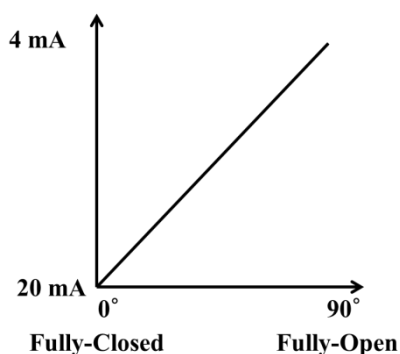

- When a low signal value received, the actuator operates toward fully-open position and when a high signal value received, the actuator operates toward fully-closed position.

Input Signal	Fully-Open (90°)	Fully-Closed (0°)
4 - 20 mA	4 mA	20 mA
1 - 5 V	1 V	5 V
2 - 10 V	2 V	10 V

- The selection of the fail position while the input signal failed, please follow table below:

Signal Failed Position	State of Switch
Fully-Open (90°)	7 at OFF, 8 at ON
Fully-Closed (0°)	7 at ON, 8 at OFF
The Last Position	7 at ON, 8 at ON

【OM Series】 Quarter -Turn Electric Valve Actuator

When S6 is set to **OFF**

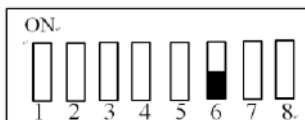

- The program defines 20 mA / 5 V / 10 V as a command for **fully-open** positioning. The line graph below shows the signal level and the corresponding position of the actuator.

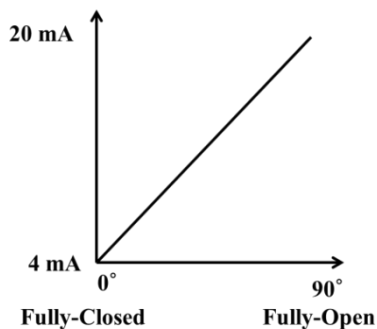

- When a high signal value received, the actuator operates toward fully-open position and when a low signal value received, the actuator operates toward fully-closed position.

Input Signal	Fully-Open (90°)	Fully-Closed (0°)
4 - 20 mA	20 mA	4 mA
1 - 5 V	5 V	1 V
2 - 10 V	10 V	2 V

- The selection of the fail position while the input signal failed, please follow table below :

Signal Failed Position	State of Switch
Fully-Open (90°)	7 at ON , 8 at OFF
Fully-Closed (0°)	7 at OFF, 8 at ON.
The Last Position	7 at ON , 8 at ON.

6.3.3 Sensitivity Switch Setting (SR1)

- OM-A, OM-AM, OM-1 to OM-13 and OM-H Factory setting:
 Select "MODBUS" control, the sensitivity is preset to 1.
 Select "analog signal" control, the sensitivity is preset to 7.
- OM-F and OM-G Factory setting:
 Select "MODBUS" control, the sensitivity is preset to 0.
 Select "analog signal" control, the sensitivity is preset to 0.
- When analog signal is selected:
 Switch to 1: the highest sensitivity.
 Switch to 0: the lowest sensitivity.



6.3.4 LED Indication

OM-A, OM-AM and OM-1

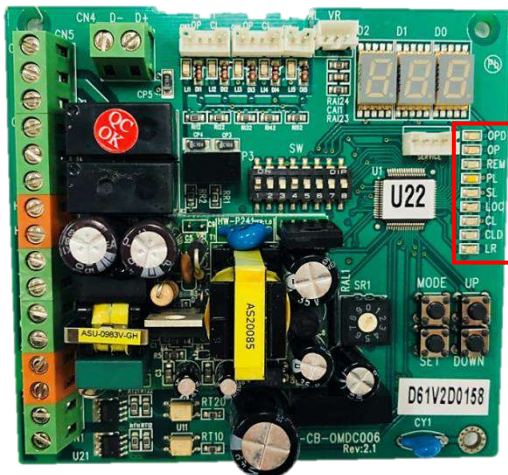

Lamp	Actuator Status
OPD	Fully-Open Position
OP	Opening Direction
REM	Remote Control Mode
PL	Alerting Signal
SL	Setting Mode
LOC	Local Control Mode
CL	Closing Direction
CLD	Fully-Closed Position
LR	MCU Indication

OM-2 to OM-13, OM-F, OM-G and OM-H



Lamp	Actuator Status
OPD	Fully-Open Position
OP	Opening Direction
REM	Remote Control Mode
PL	Alerting Signal
SL	Setting Mode
LOC	Local Control Mode
CL	Closing Direction
CLD	Fully-Closed Position
LR1	MCU Indication

6.3.5 Travel Setting

- Press “MODE” 5 times to get into **Auto**.
- Press and hold “SET” around 5 sec until “LOC” comes on to enter Auto setting mode.
- When the Auto setting is completed, “LOC” comes off and the actuator stops running. The travel setting is completed.

6.3.6 Signal Setting



 **If the travel end positions have not been set up properly per 6.3.5 follow steps below to recalibrate.**

- **Input signal setting for fully-closed position**
 - a. Press “MODE” several times until **lo** displays, then press “SET” once to enter signal setting mode.
 - b. Press “UP” or “Down” until **2r** displays.
 - c. Press and hold “SET” around 3 sec until **2r** flashes.
 - d. Input signal according to the dip switch setting (1 V or 2 V or 4 mA).
 - e. Press “SET” once and then “MODE” 2 times to complete the input signal setting for fully-closed position.

- **Input signal setting for fully-open position**
 - a. Press ”MODE” several times until **lo** displays, then press “SET” once to enter signal setting mode.
 - b. Press ”UP” or ”DOWN” until **FU** displays.
 - c. Press and hold ”SET” around 3 sec until **FU** flashes.
 - d. Input signal according to the dip switch setting (5 V or 10 V or 20 mA).
 - e. Press ”SET” once and “MODE” 2 times to complete the input signal setting for fully-open position.



- **Output signal setting for fully-closed position**

 **Use a multimeter to measure the output signal in accordance with the selected signal type.**

- a. Press "MODE" several times until  displays, then press "SET" once to enter signal setting mode.
- b. Press "UP" or "DOWN" until  displays.
- c. Press and hold "SET" around 3 sec.
- d. Select signal value by pressing "UP" or "DOWN" until the required value is achieved.
- e. Press "SET" once and "MODE" 2 times to complete the output signal setting for fully-closed position.

- **Output signal setting for fully-open position**

 **Use a multimeter to measure the output signal in accordance with the selected signal type.**

- a. Press "MODE" several times until  displays, then press "SET" once to enter signal setting mode.
- b. Press "UP" or "DOWN" until  displays.
- c. Press and hold "SET" around 3 sec.
- d. Select signal value by pressing "UP" or "DOWN" until the required value is achieved.
- e. Press "SET" once and "Mode" 2 times to complete the output signal setting for fully-open position.

6.3.7 Time Delay Setting (OM-A, OM-AM, OM-1)

- a. Press "MODE" several times until **PAR** displays, then press "SET" once to enter parameter setting mode.
- b. Get into **SPd** and Press and hold "SET" around 3 sec to enter setting mode.
- c. Follow the table below to select the required timing by pressing "UP" or "DOWN".

Selection	1	2	3	4	5	6	7	8	9	10
Running time (Sec)	Standard	30	60	80	100	120	150	180	200	200

 **If the setting time is less than the original time of the actuator, the product can't be executed according to the running time of the set segment.**

- d. Press "SET" once to complete the time delay setting.
- e. Press "MODE" 5 times to go back to position indicator to complete the setting.

6.3.8 Warning Message

- a. Press "MODE" once until **FL** displays, then press "SET" once to get into warning message.
- b. Press "UP" or "DOWN" to review the history log of warning message.

【OM Series】 Quarter -Turn Electric Valve Actuator

OM-A, OM-AM, OM-1

9.55

↑ ↑

Item Warning Message

<u>Item (9,8,7...0)</u>	<u>Warning Message</u>	<u>Solution</u>
<div style="display: flex; flex-direction: column; align-items: center;"> <div style="margin-bottom: 2px;">9</div> <div style="margin-bottom: 2px;">8</div> <div style="margin-bottom: 2px;">7</div> <div style="margin-bottom: 2px;">6</div> <div style="margin-bottom: 2px;">5</div> <div style="margin-bottom: 2px;">4</div> <div style="margin-bottom: 2px;">3</div> <div style="margin-bottom: 2px;">2</div> <div style="margin-bottom: 2px;">1</div> <div style="margin-bottom: 2px;">0</div> </div> <p style="color: red; text-align: center;">(The latest data)</p>	<div style="text-align: center; margin-bottom: 10px;">01</div> <p>Abnormal Input signal.</p> <hr/> <div style="text-align: center; margin-bottom: 10px;">55</div> <p>No abnormal records.</p>	<p>a. Check if the input signal and dip switch settings are correct.</p>
<p style="text-align: center;">(The oldest data)</p>		

OM-2 to OM-13,

OM-F, OM-G, OM-H

99.5

↑ ↑





Item Warning Message

<u>Item (99,98,97...0)</u>	<u>Warning Message</u>	<u>Solution</u>
<div style="display: flex; flex-direction: column; align-items: center;"> <div style="margin-bottom: 2px;">99</div> <div style="margin-bottom: 2px;">98</div> <div style="margin-bottom: 2px;">97</div> <div style="margin-bottom: 2px;">96</div> <div style="margin-bottom: 2px;">95</div> <div style="margin-bottom: 2px;">94</div> <div style="margin-bottom: 2px;">93</div> <div style="margin-bottom: 2px;">92</div> <div style="margin-bottom: 2px;">91</div> <div style="margin-bottom: 2px;">90</div> <div style="margin-bottom: 2px;">⋮</div> <div style="margin-bottom: 2px;">0</div> </div> <p style="color: red; text-align: center;">(The latest data)</p>	<div style="text-align: center; margin-bottom: 10px;">!</div> <p>Abnormal Input signal.</p> <hr/> <div style="text-align: center; margin-bottom: 10px;">0</div> <p>No abnormal records.</p>	<p>a. Check if the input signal and dip switch settings are correct.</p>
<p style="text-align: center;">(The oldest data)</p>		







The latest data is listed at the top, the oldest data at the bottom.

- **Example 1**

- a. If you want to check the latest data, press “MODE” several times until  displays → Press “Set” once → The LED display will show the latest data .
- b. If you want to check the eighth data, press “MODE” several times until  displays → Press “SET” once → Press “DOWN” seven times and the LED display will show the eighth data .

- **Example 2**

- a. If you want to check the latest data, press “MODE” several times until  displays → Press “Set” once → The LED display will show the latest data .
- b. If you want to check the eighth data, press “MODE” several times until  displays → Press “SET” once → Press “DOWN” seven times and the LED display will show the eighth data .

6.3.9 MODBUS Setting

⚠ MODBUS and modulating control cannot service at the same time.

- **MODBUS :**

Set switches 1 - 2 at “ON” state and switches 3 - 8 at “OFF” state.

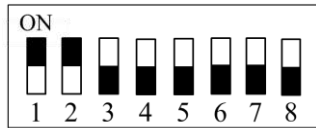

- **Baud rate setting**

- Press "MODE" 2 times until **PAR** displays.
- Press "SET" once, then **SPD** will display.
- Press "DOWN" 10 times until **BAU** displays.
- Press and hold "SET" around 3 sec until the LED indicator flashes to enter setting mode.
- Press "UP" or "DOWN" to set the required baud rate. (default value #4)

Setting Value	Baud rate
4 (default)	9600
5	19200

- Press "SET" once to complete the setting.

- **Setting station**

- Press "DOWN" once, then **Id** will display.
- Press and hold "SET" around 3 sec until the LED indicator flashes to enter setting mode.
- Press "UP" or "DOWN" to select the required station (Station Range:1 to 127, default Station: 1).
- Press "Set" once to complete the setting.

- **Press "Mode" 4 times to get back to the home page.**

6.3.10 MODBUS Parameter Address

Parameter Address (Hexadecimal)	Function	Setting range (Hexadecimal)
5	Station setting for MODBUS	1 to 127 station
6	Baud rate setting for MODBUS	4 to 5
8	Position setting (%)	0 to 64
9	Position feedback (%)	0 to 64

7. Troubleshooting

Floating Controller

Motor does not operate or overheats

Possible problems	Solution
a. The limit switch for fully-closed does not trip.	a. Operate the actuator manually to fully-closed position and confirm if the limit switch trips.
b. Motor shaft or bearing were stuck.	b. Replace a new motor.
c. Power applied to terminals #3 and #4 simultaneously (Abnormal Wiring).	c. Follow the wiring diagram inside the cover to connect wires and make sure the wiring is correct.
d. Jammed pipe or valve seat stuck.	d. Check if any blockage or obstacle in pipe and remove.
e. The seating torque of valve increased caused by oxidized seals and has resulted in a torque overload on actuator.	e. Manual operate to check if it can be operated, if not, replace the valve.

The actuator operates but the motor is hot.

Possible problems	Solution
a. The mechanical stop screws ran into the output drive gearing.	a. Reset the mechanical end stops and travel cams, please refer to 4.4.2 (P.11 - P.15).
b. A torque overload caused by the valve.	b. This problem happened frequently after valve operating for a long time. It is suggested to replace with a new valve.
c. Wrong power supply.	c. Check the power supply.
d. Actuator operates too frequently and exceeded duty cycle rating.	d. Adjust the system bandwidth or reduce the frequency of operation, please refer to 3.5 (P.6).

To control two or more actuators, sometimes the actuator works abnormally and the motor is getting hot.

Possible problems	Solution
Parallel connection.	a. Install Isolating Relay Module (Optional). b. Please contact your distributor to acquire the wiring diagram for parallel connection.

The valve does not operate no matter under either electrical operation or manual operation.

Possible problems	Solution
<ul style="list-style-type: none"> a. The actuator was mounted to the valve improperly. b. The set screw of the cam loosened and resulted in that the travel end positions misaligned. c. The torque of valve is larger than the torque of actuator. d. The actuator was mounted to the valve improperly. 	<ul style="list-style-type: none"> a. Please refer to 4.2 (P.8) valve installation instructions. b. Readjust the mechanical end stops and limit switches, please refer to 4.4.2 (P.11 - P.15). c. Replace with a new valve or a larger size actuator. d. Disassemble the actuator from the valve and reassemble them to verify that they are installed properly.

When power is on, LED indicators did not function.

Possible problems	Solution
<ul style="list-style-type: none"> a. Blown fuse. b. PCB failed. c. Wrong supply voltage. 	<ul style="list-style-type: none"> a. Replace a new fuse. b. Replace a new PCB. c. Check the power supply.

The capacitor is failed.

Possible problems	Solution
Worked in an environment out of the with stand able temperature range.	Please use the capacitor at temperature between -30 °C to +65 °C (-22 °F to + 149 °F).

Modulating Controller

The LED indicators (LD4 - LD9) flash. (OM-2 to OM-13, OM-F, OM-G & OM-H)

Solution
Please refer to 6.2.6 (P.29 - P.30).

The LED indication functions properly but the actuator could operate to fully-open as well as fully-closed, modulating control was out of function.

Possible problems	Solution
The input signal with a reversed polarity, it means a signal failure.	Verify if the negative pole of signal input connected to terminal #6 and the positive pole connected to terminal #7.

Modulating control was out of function.

Possible problems	Solution
a. Potentiometer failed and causes actuator out of control in some section or abnormal feedback.	a. Replace a new potentiometer.
b. Input wrong signal type.	b. Check if the input signal is correct, please refer to 6.1.3 (P.18 - P.20) or 6.2.3 (P.24 - P.29).
c. Modulating board failed and causes actuator cannot operate or only operate in a single direction	c. Replace a new modulating board.

8. Warranty

Sun Yeh Ele. Co. Ltd warrants that for a period of twelve months from the date of manufacture it will either repair or replace, at its option, any of its products which prove to be defective in material or workmanship. This warranty does not cover damage resulting from causes such as abuse, misuse, modification or tampering by users. This warranty is extended only to the immediate purchaser of the Sun Yeh product and is not transferable. To obtain service under this warranty, the purchaser must first acquire a return authorization from Sun Yeh. Products must be returned to Sun Yeh under freight prepaid.

This warranty is in lieu of all other obligations, liabilities or expressed warranties. Any implied warranties, including any implied warranty of merchantability are hereby expressly excluded. In no event shall Sun Yeh be liable for special, incidental or consequential damages arising in connection with the use of its products, or for any delay in the performance of this warranty due to cause beyond its control.

9. Disposal

Please obey the local environment regulation for equipment scrapping.



SUN YEH ELECTRICAL IND. CO.,LTD.

No.68, Ln. 854, Sec. 1, Shatian Rd., Dadu Dist.,
Taichung City 432403, Taiwan
Tel: +886-4-26985666 Fax: +886-4-26983668
E-mail: service@sunyeh.com

www.sunyeh.com

