



Datasheet

RS PRO Type 2 15mm diax6mm H

Stock number: 172-0857

EN



DIMENSIONS	TOLERANCE
<4mm	±0.15
4mm~15mm	±0.20
15mm~30mm	±0.30
30mm~50mm	±0.50
50mm~100mm	±1.00

REVISIONS			
REV	DESCRIPTION	DATE	BY
01	NEW DRAWING	2016-7-16	Jack Xu

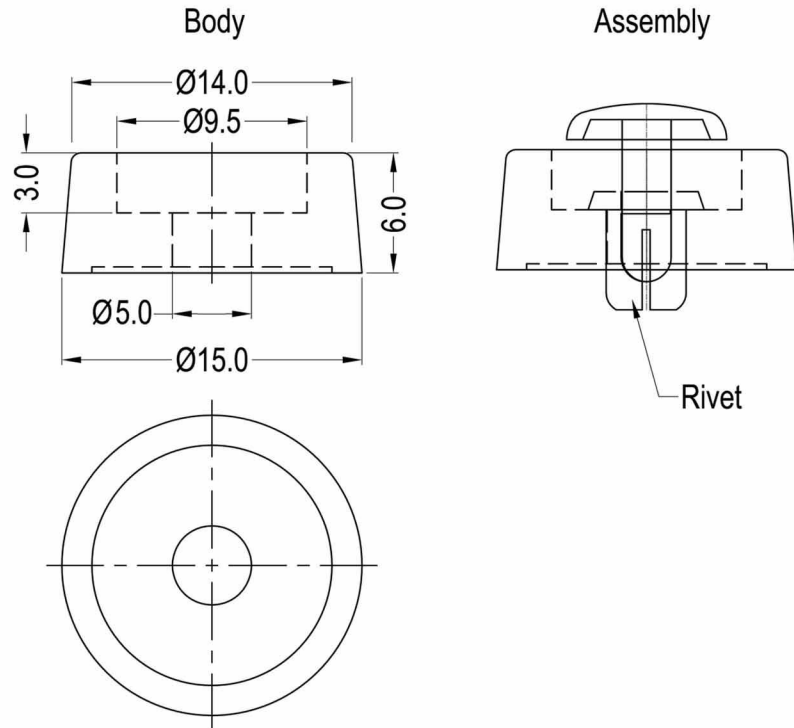

NOTES:

- MATERIAL: TPV UL94 HB(Body)
PA6 UL94 V2(Rivet)
- Hole: Ø5.1~5.2mm
Panel Thickness: 0.8~1.2mm
Mounting Rivet R5065B

Unit:mm

SCALE	2:1	PART NAME	Soft Fast Foot
COLOR	BLACK	PART NO.	172-0857
DRAWN	ALEX	MATERIAL	SEE NOTES
CHECK	JACK	DRAWING NO.	KS180712-9
APPROVED	FRED	DRAWING DATE	2016-7-16