



Datasheet

ENGLISH

## RS Pro VF Range of Height Adjustable and Articulated Machinery Mount



### Product Details

Load values above mentioned are to be considered using static conditions and are calculated at half of the screw length. In presence of dynamic loads these values should be suitably reduced (please consult our selection guide for details)

The VF mounts are used for levelling and support, it in many applications including lathes, milling machines, machining centres and conveyor systems. The base rubber is made of oil resistant NBR, with the stainless steel versions being commonly used in the food industry.

# Dimensions & Range Table

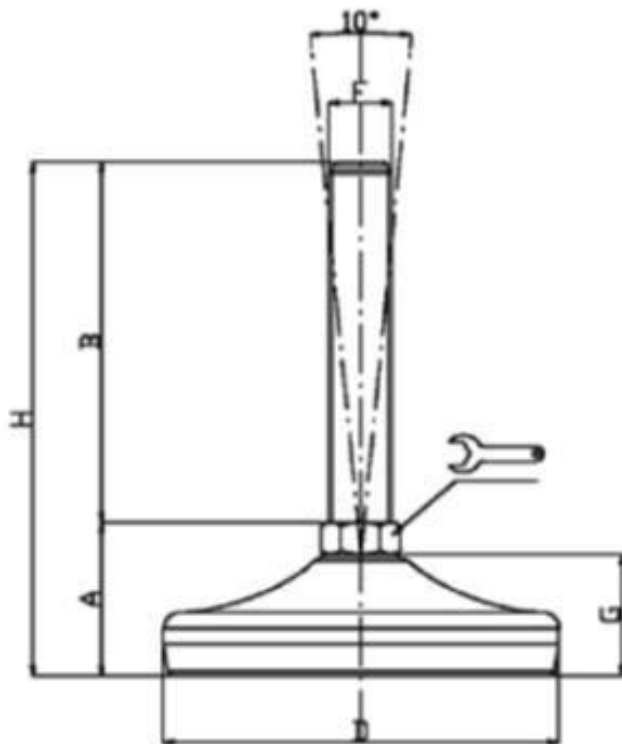

RS Stock number	A	B Thread length (mm)	D Diameter (mm)	F Thread size	G Foot height (mm)	H Overall height (mm)	Static Load KG	Metal Type	Articulation Degrees
1263554	37.5	150	100	M16	28	187.5	1500	MS	10
1263558	41.5	100	120	M16	32	191.5	3000	MS	10
1263555	29	100	50	M10	19	129	400	MS	10
1266372	19	100	63	M14	11.5	119	1800	MS	5
1263563	32	100	60	M10	22	132	700	A4	10
1263550	35	125	80	M14	12	25	1000	A4	10
1263560	38	125	80	M16	25	163	1000	A4	10
1263553	35	155	80	M12	25	85	1000	MS	10
1263562	35	150	80	M16	25	185	1000	MS	10
1263551	19	100	50	M12	11.5	119	1500	MS	5
1263564	31	125	100	M16	28	156	900	MS	5

MS – Mild Steel A4 – SS304 Stainless Steel