

Issue	Description	Date
A	修改编号	2012/04/19

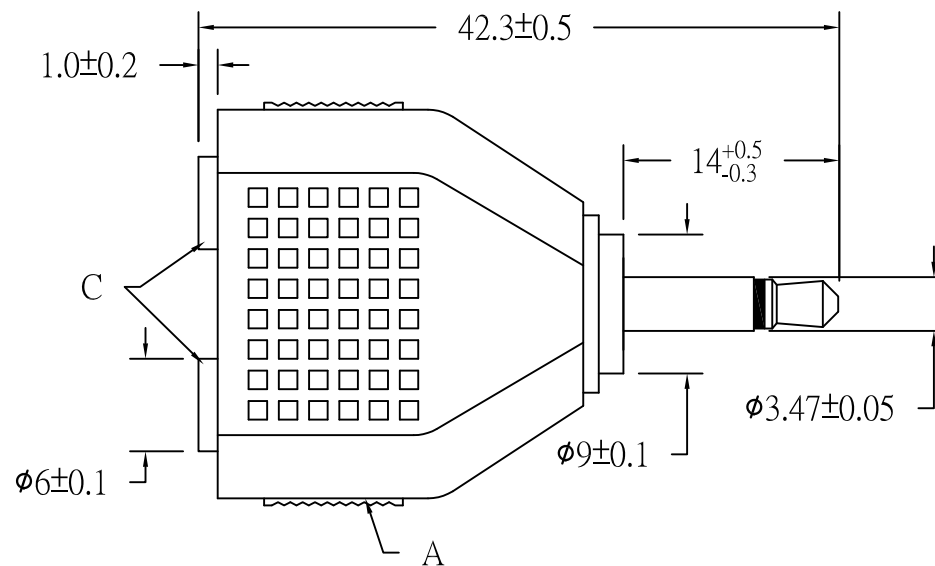

CUSTOMER P/N.

G.						All Dimensions are Millimeters				Approved	Checked	Drawn		
F.						Unless Otherwise Specified Tolerances						何文霞		
E.						0.5~6= ±0.1						2012/04/19		
D.						6~30= ±0.3								
C.	3.5MJ	2	BRASS	NICKEL		30~120= ±0.5							AA635	
B.	3.5MP	1	BRASS	NICKEL		120~315= ±0.8				TITLE	3.5MP TO 2*3.5MJ			
A.	SHELL	2	PLASTIC	BLACK		ANGLES= ±3°				CABLE				
NO	Description	Unit	Materials	Finish/Color	PART NO.	Scale	2:1	Issue	A					

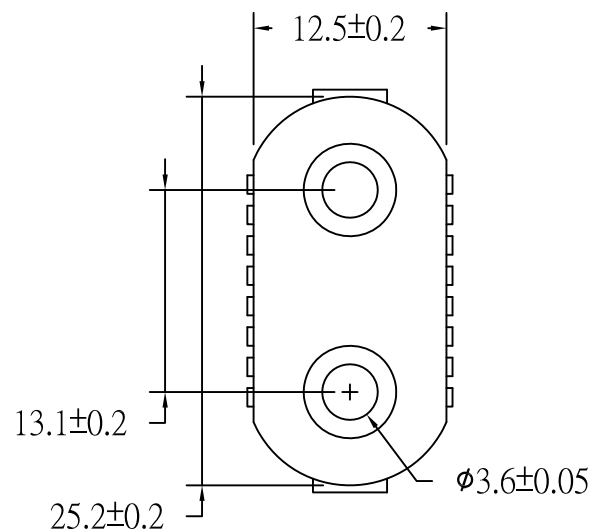