

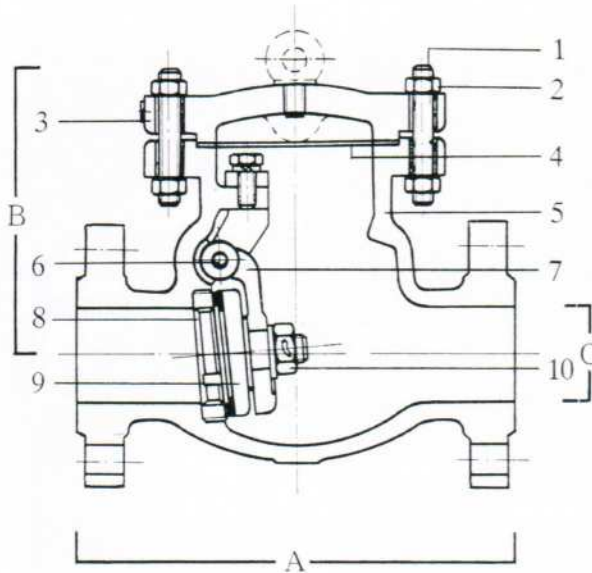

ISUKA VALVE MFG. CO., LTD.

SWING CHECK VALVES CAST STEEL BOLTED BONNET ANSI CLASS 150



NO.	PARTS	MAERIALS
1	Cp Sud Bolt	ASTM A193 Gr. B7
2	Cap Stud Bolt Nut	ASTM A194 Gr. 2H
3	Cap	ASTM A216 Gr. WCB
4	Gaske	Soft steel
5	Body	ASTM A216 Gr. WCB
6	Hinge Pin	ASTM A182 Gr. F6a
7	Hinge	ASTM A216 Gr. WCB
8	Seat Ring	ASTM A105 + Stellite
9	Disc	ASTM A216 Gr. WCB + Cr. 13
10	Disc Retaining Nut	ASTM A194 Gr. 2H

APPLICABLE CLASS 150 STANDARDS:
Steel Valves, ANSI B16.34
Face-to-Face, End-to-End, ANSI B16.10
End Flanges, ANSI B16.5
Weld Ends, ANSI B16.25

TESTS:
API 598
Shell: 450 PSIG Hydrostatic
Seat: 315 PSIG Hydrostatic
80 PSIG Air
Other testing available upon request.

DIMENSIONS IN INCHES & MILLIMETERS (Approx.):

SIZE	2"	2-1/2"	3"	4"	5"	6"	8"	10"	12"	14"	16"	18"	20"	24"
	50mm	65mm	80mm	100mm	130mm	150mm	200mm	250mm	300mm	350mm	400mm	450mm	500mm	600mm
A Face to Face RF	8.0 203	8.5 216	9.5 241	11.5 292	13.0 330	14.0 356	19.5 495	24.5 622	27.5 698	31.0 787	34.0 864	38.5 978	38.5 978	51 1295
A End to End BW	8.0 203	8.5 216	9.5 241	11.5 292	13.0 330	14.0 356	19.5 495	24.5 622	27.5 699	31.0 787	34.0 864	38.5 978	38.5 978	51 1295
B Center to Top	6.0 152	6.7 170	7.1 180	7.9 200	9.0 229	9.8 250	11.6 295	13.2 334	14.5 368	16.3 415	18.1 460	20.1 510	21.7 550	24.8 630
C Valve Port	2.0 51	2.5 64	3.0 76	4.0 102	5.0 127	6.0 152	8.0 203	10.0 254	12.0 305	13.25 337	15.25 387	17.25 438	19.25 489	23.24 591
WEIGHT(Lbs) RF (kg)	41 19	53 24	62 28	106 48	138 63	174 79	286 130	440 200	660 300	814 370	924 420	1380 626	1710 776	2620 1188

ISUKA VALVE MFG. CO., LTD.



SWING CHECK VALVES CAST STEEL BOLTED BONNET ANSI CLASS 300

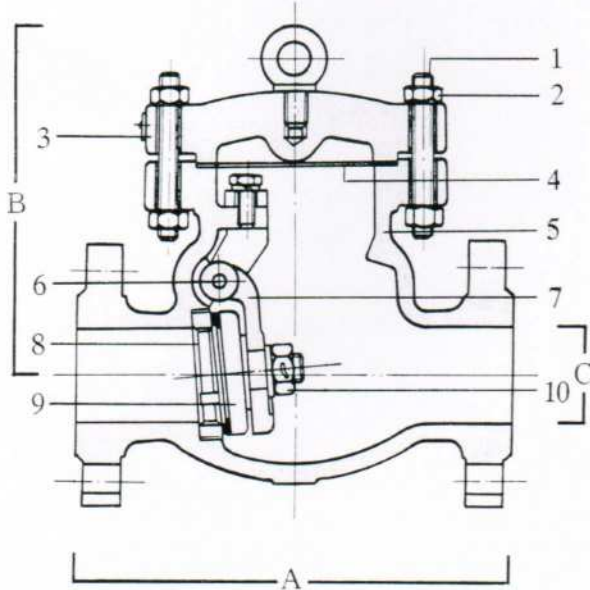

NO.	PARTS	MAERIALS
1	Cp Sud Bolt	ASTM A193 Gr. B7
2	Cap Stud Bolt Nut	ASTM A194 Gr. 2H
3	Cap	ASTM A216 Gr. WCB
4	Gaske	Soft steel
5	Body	ASTM A216 Gr. WCB
6	Hinge Pin	ASTM A182 Gr. F6a
7	Hinge	ASTM A216 Gr. WCB
8	Seat Ring	ASTM A105 + Stellite
9	Disc	ASTM A216 Gr. WCB + Cr. 13
10	Disc Retaining Nut	ASTM A194 Gr. 2H

APPLICABLE CLASS 300 STANDARDS:
Steel Valves, ANSI B16.34
Face-to-Face, End-to-End, ANSI B16.10
End Flanges, ANSI B16.5
Weld Ends, ANSI B16.25

TESTS:
API 598
Shell: 1125 PSIG Hydrostatic
Seat: 815 PSIG Hydrostatic
80 PSIG Air
Other testing available upon request.

DIMENSIONS IN INCHES & MILLIMETERS (Approx.):

SIZE	2" 50mm	2-1/2" 65mm	3" 80mm	4" 100mm	5" 130mm	6" 150mm	8" 200mm	10" 250mm	12" 300mm				
A Face to Face RF	10.5 267	11.5 292	12.5 318	14.0 356	15.75 400	17.5 444	21.0 533	24.5 622	28.0 711				
A End to End BW	10.5 267	11.5 292	12.5 318	14.0 356	15.75 400	17.5 444	21.0 533	24.5 622	28.0 711				
B Center to Top	6.5 165	7.5 190	8.7 205	8.9 225	9.5 241	10.7 272	13.0 330	14.2 360	16.0 406				
C Valve Pore	2.0 51	2.5 64	3.0 76	4.0 102	5.0 127	6.0 152	8.0 203	10.0 254	12.0 305				
WEIGHT(Lbs) RF (kg)	68 31	86 39	99 45	150 68	198 90	299 136	462 210	693 315	946 430				



ISUKA VALVE MFG. CO., LTD.

SWING CHECK VALVES CAST STEEL BOLTED BONNET ANSI CLASS 600

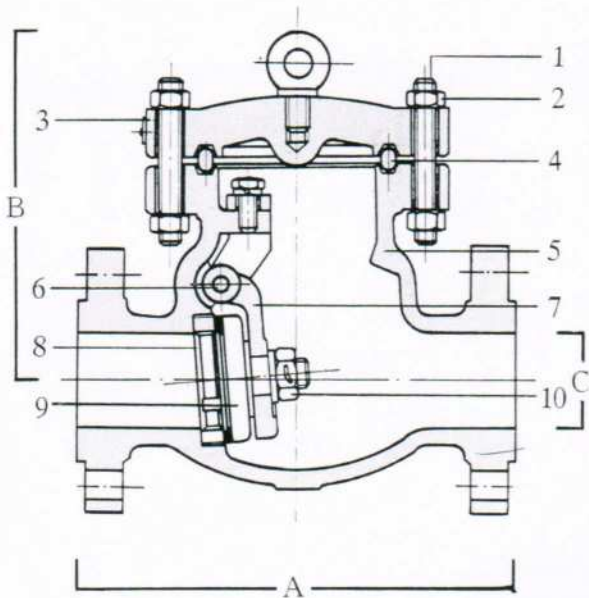

NO.	PARTS	MAERIALS
1	Cp Sud Bolt	ASTM A193 Gr. B7
2	Cap Stud Bolt Nut	ASTM A194 Gr. 2H
3	Cap	ASTM A216 Gr. WCB
4	Gaske	Oval ring
5	Body	ASTM A216 Gr. WCB
6	Hinge Pin	ASTM A182 Gr. F6a
7	Hinge	ASTM A216 Gr. WCB
8	Seat Ring	ASTM A105 + Stellite
9	Disc	ASTM A216 Gr. WCB + Cr. 13
10	Disc Retaining Nut	ASTM A194 Gr. 2H

APPLICABLE CLASS 600 STANDARDS:
Steel Valves, ANSI B16.34
Face-to-Face, End-to-End, ANSI B16.10
End Flanges, ANSI B16.5
Weld Ends, ANSI B16.25

TESTS:
API 598
Shell: 2225 PSIG Hydrostatic
Seat: 1630 PSIG Hydrostatic
80 PSIG Air
Other testing available upon request.

DIMENSIONS IN INCHES & MILLIMETERS (Approx.) :

SIZE	2" 50mm	2-1/2" 65mm	3" 80mm	4" 100mm	5" 130mm	6" 150mm	8" 200mm	10" 250mm	12" 300mm					
A Face to Face RF	11.5 292	13.0 330	14.0 356	17.0 432	20.0 508	22.0 559	26.0 660	31.0 787	33.0 838					
A End to End BW	11.5 292	13.0 330	14.0 356	17.0 432	20.00 508	22.0 559	26.0 660	31.0 787	33.0 838					
B Center to Top	7.1 180	7.8 197	8.7 220	10.1 256	11.5 292	12.4 316	14.0 356	16.3 415	17.7 450					
C Valve Port	2.0 51	2.5 64	3.0 76	4.0 102	5.0 127	6.0 152	7.875 200	9.75 248	11.75 298					
WEIGHT(Lbs) RF (kg)	70 32	92 42	132 60	242 110	354 161	486 221	783 356	1199 545	1716 780					

ISUKA VALVE MFG. CO., LTD.



SWING CHECK VALVES CAST STEEL BOLTED BONNET ANSI CLASS 900

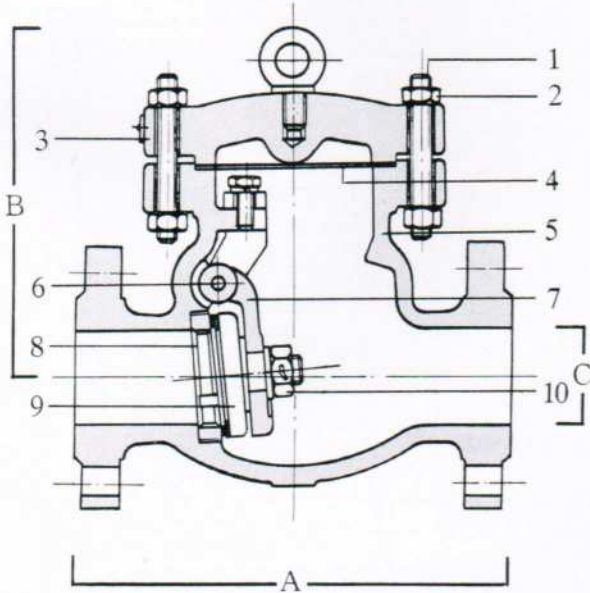

NO.	PARTS	MAERIALS
1	Cp Sud Bolt	ASTM A193 Gr. B7
2	Cap Stud Bolt Nut	ASTM A194 Gr. 2H
3	Cap	ASTM A216 Gr. WCB
4	Gaske	Oval ring
5	Body	ASTM A216 Gr. WCB
6	Hinge Pin	ASTM A182 Gr. F6a
7	Hinge	ASTM A216 Gr. WCB
8	Seat Ring	ASTM A105 + Stellite
9	Disc	ASTM A216 Gr. WCB + Cr. 13
10	Disc Retaining Nut	ASTM A194 Gr. 2H

APPLICABLE CLASS 900 STANDARDS:
Steel Valves, ANSI B16.34
Face-to-Face, End-to-End, ANSI B16.10
End Flanges, ANSI B16.5
Weld Ends, ANSI B16.25

TESTS:
API 598
Shell: 3350 PSIG Hydrostatic
Seat: 2440 PSIG Hydrostatic
80 PSIG Air
Other testing available upon request.

DIMENSIONS IN INCHES & MILLIMETERS (Approx.):

SIZE	3" 80mm	4" 100mm	6" 150mm	8" 200mm	10" 250mm	12" 300mm							
A Face to Face RF	15.0 381	18.0 457	24.0 610	29.0 737	33.0 838	38.0 965							
A End to End BW	15.0 381	18.0 457	24.0 610	29.0 737	33.0 838	38.0 965							
B Center to Top	11.5 292	13.6 346	17.5 444	20.7 526	24.4 620	28.3 720							
C Valve Port	2.875 73	3.875 98	5.75 146	7.5 191	9.375 238	11.125 283							
WEIGHT (Lbs) RF (kg)	216 98	350 159	660 299	1220 553	1910 866	3090 1402							



ISUKA VALVE MFG. CO., LTD.

SWING CHECK VALVES CAST STEEL BOLTED BONNET ANSI CLASS 1500, 2500

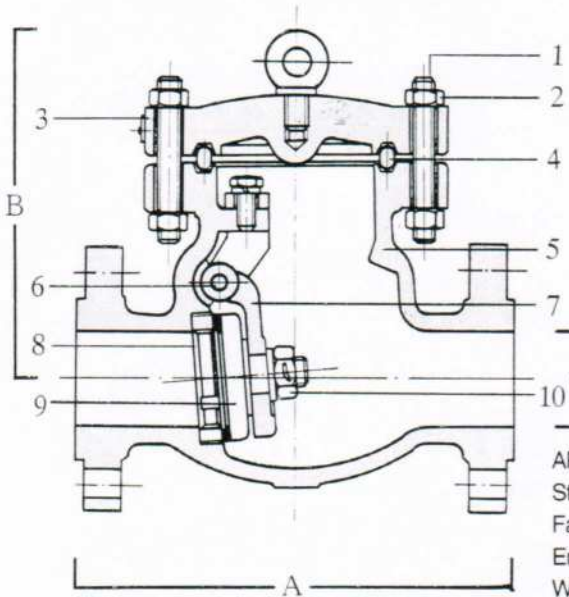

NO.	PARTS	MAERIALS
1	Cp Sud Bolt	ASTM A193 Gr. B7
2	Cap Stud Bolt Nut	ASTM A194 Gr. 2H
3	Cap	ASTM A216 Gr. WCB
4	Gaske	Oval ring
5	Body	ASTM A216 Gr. WCB
6	Hinge Pin	ASTM A182 Gr. F6a
7	Hinge	ASTM A216 Gr. WCB
8	Seat Ring	ASTM A105 + Stellite
9	Disc	ASTM A216 Gr. WCB + Cr. 13
10	Disc Retaining Nut	ASTM A194 Gr. 2H

APPLICABLE CLASS 1500, 2500 STANDARDS:
 Steel Valves, ANSI B16.34
 Face-to-Face, End-to-End, ANSI B16.10
 End Flanges, ANSI B16.5
 Weld Ends, ANSI B16.25

CLASS 1500

DIMENSIONS IN INCHES & MILLIMETERS (Approx.):

SIZE	2" 50mm	3" 80mm	4" 100mm	6" 150mm	8" 200mm	10" 250mm	12" 300mm						
A Face to Face RF	14.5 368	18.5 470	21.5 546	27.75 705	32.75 832	39 991	44.5 1130						
A End to End BW	14.5 368	18.5 470	21.5 546	27.75 705	32.75 832	39 991	44.5 1130						
B Center to Top	11.4 290	13.7 347	15.4 391	20.3 515	25.6 650	29.0 737	34.4 875						
C Valve Port	1.875 48	2.75 70	3.375 86	5.375 137	7 178	8.75 222	10.375 264						
WEIGHT(Lbs) RF (kg)	185 84	310 141	515 234	1290 585	2150 975	3710 1683	5280 2395						

CLASS 2500

SIZE	2" 50mm	2-1/2" 65mm	3" 80mm	4" 100mm	6" 150mm								
A Face to Face RF	17.75 451	20 508	22.75 578	26.5 673	36 914								
A End to End BW	17.75 451	20 508	22.75 578	26.5 673	36 914								
B Center to Top	13.2 335	15.2 385	15.7 400	17.7 450	22.8 580								
C Valve Port	1.5 38	1.875 48	2.25 57	2.875 73	4.375 111								
WEIGHT(Lbs) RF (kg)	215 98	350 159	690 313	1580 717	2990 1356								