



ENGLISH

Datasheet

RS PRO Diffuse Photoelectric Sensor with Block Sensor

Stock No: 729-5148



Illustration may differ



Detailed technical data

Features

Sensor/ detection principle	Photoelectric proximity sensor, Energetic
Dimensions (W x H x D)	15.6 mm x 48.5 mm x 42 mm
Housing design (light emission)	Rectangular
Sensing range max.	40 mm ... 1,000 mm ¹⁾
Sensing range	40 mm ... 600 mm
Type of light	Visible red light
Light source	LED ²⁾
Light spot size (distance)	Ø 90 mm (600 mm)
Wave length	633 nm
Adjustment	Single teach-in button

¹⁾ Object with 90 % reflectance (referred to standard white, DIN 5033).

²⁾ Average service life: 100,000 h at T_J = +25 °C.

Mechanics/electronics

Supply voltage	10 V DC ... 30 V DC ¹⁾
Ripple	≤ 5 V _{pp} ²⁾

¹⁾ Limit values when operated in short-circuit protected network: max. 8 A.

²⁾ May not exceed or fall below U_v tolerances.

³⁾ Without load.

⁴⁾ Signal transit time with resistive load.

⁵⁾ With light/dark ratio 1:1.

⁶⁾ A = V_S connections reverse-polarity protected.

⁷⁾ C = interference suppression.

⁸⁾ D = outputs overcurrent and short-circuit protected.

Current consumption	30 mA ³⁾
Switching output	PNP
Output function	Complementary
Switching mode	Light/dark switching
Signal voltage PNP HIGH/LOW	U _v - 2.5 V / approx. 0 V
Output current I_{max.}	100 mA
Response time	≤ 2.5 ms ⁴⁾
Switching frequency	200 Hz ⁵⁾
Connection type	Male connector M12, 4-pin
Circuit protection	A ⁶⁾ C ⁷⁾ D ⁸⁾
Protection class	II
Weight	120 g
Housing material	Plastic, ABS
Optics material	Plastic, PMMA
Enclosure rating	IP66 IP67
Ambient operating temperature	-30 °C ... +60 °C
Ambient storage temperature	-40 °C ... +75 °C
UL File No.	NRKH.E181493 & NRKH7.E181493

1) Limit values when operated in short-circuit protected network: max. 8 A.

2) May not exceed or fall below U_v tolerances.

3) Without load.

4) Signal transit time with resistive load.

5) With light/dark ratio 1:1.

6) A = V_S connections reverse-polarity protected.

7) C = interference suppression.

8) D = outputs overcurrent and short-circuit protected.

Classifications

ECI@ss 5.0	27270903
ECI@ss 5.1.4	27270903
ECI@ss 6.0	27270903
ECI@ss 6.2	27270903
ECI@ss 7.0	27270903
ECI@ss 8.0	27270903
ECI@ss 8.1	27270903
ECI@ss 9.0	27270903
ECI@ss 10.0	27270904
ECI@ss 11.0	27270904
ETIM 5.0	EC001821
ETIM 6.0	EC001821
ETIM 7.0	EC002719

Connection diagram

Cd-083

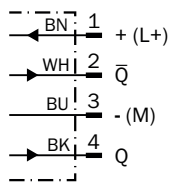

Characteristic curve

WTE11-2

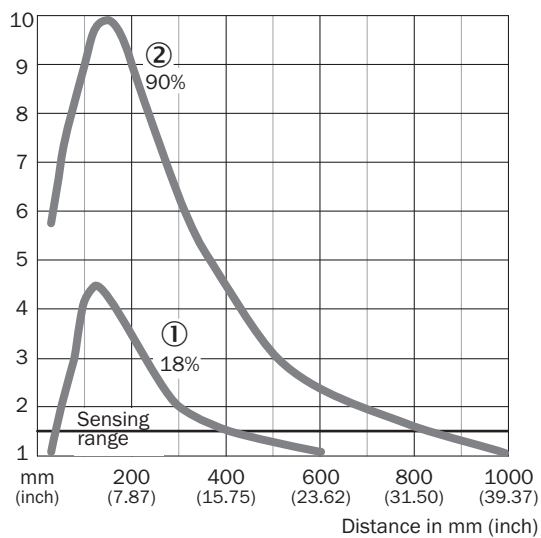

- ① Sensing range on gray, 18 % remission
 ② Sensing range on white, 90 % remission

Sensing range diagram

WTE11-2

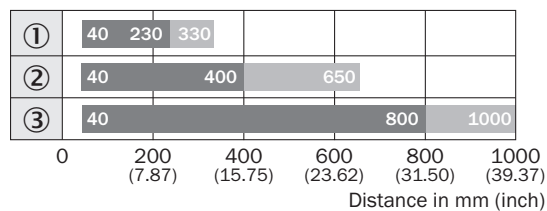

■ Sensing range ■ Sensing range typ. max.

- ① Sensing range on black, 6% remission
 ② Sensing range on gray, 18 % remission
 ③ Sensing range on white, 90% remission

Adjustments

WTE11-2, WSE11-2

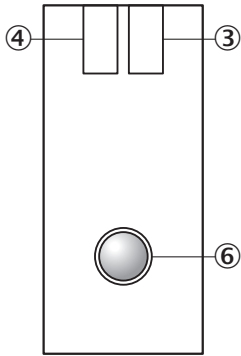

- ③ LED indicator green: Supply voltage active
- ④ LED indicator yellow: Status of received light beam
- ⑥ Adjustment sensing range: single teach-in button

Dimensional drawing (Dimensions in mm (inch))

WTE11-2

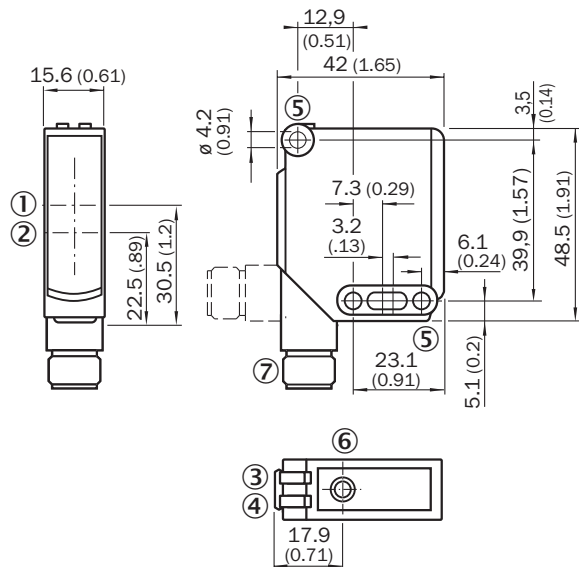

- ① Optical axis, sender
- ② Optical axis, receiver
- ③ LED indicator green: Supply voltage active
- ④ LED indicator yellow: Status of received light beam
- ⑤ Mounting hole \varnothing 4.2 mm
- ⑥ Sensitivity setting: single teach-in button
- ⑦ Connector M12 or cable

Brief description

Mounting brackets and plates



Mounting bracket, large, stainless steel, mounting hardware included

Plug connectors and cables



Head A: female connector, M12, 4-pin, straight, A-coded
Head B: Flying leads
Cable: Sensor/actuator cable, PVC, unshielded, 5 m



Head A: male connector, M12, 4-pin, straight
Head B: -
Cable: unshielded