

Embedded Switch Mode Power Supplies (SMPS)

FEATURES

- Universal 85 - 264V AC Active PFC
- Compact size: 4" × 2" × 1"
- Efficiency up to 95%
- Stand-by power consumption. < 0.5W
- Operating temperature range - 40°C to +70°C
- Conformally coated PCB
- Low leakage current < 0.1mA
- Output short circuit, over-current, over-voltage protection.
- EMI performance meets. CISPR32 / EN55032 CLASS B
- Medical and Industrial safety approvals. Suitable for BF application

IEC/EN/UL62368-1,
IEC/EN60335-1,
IEC/EN61558-1, GB4943-1,
IEC/EN60601-1 (2 × MOPP)

RS PRO Embedded Switch Mode Power Supplies

- 233-6881
- 233-6883
- 233-6886

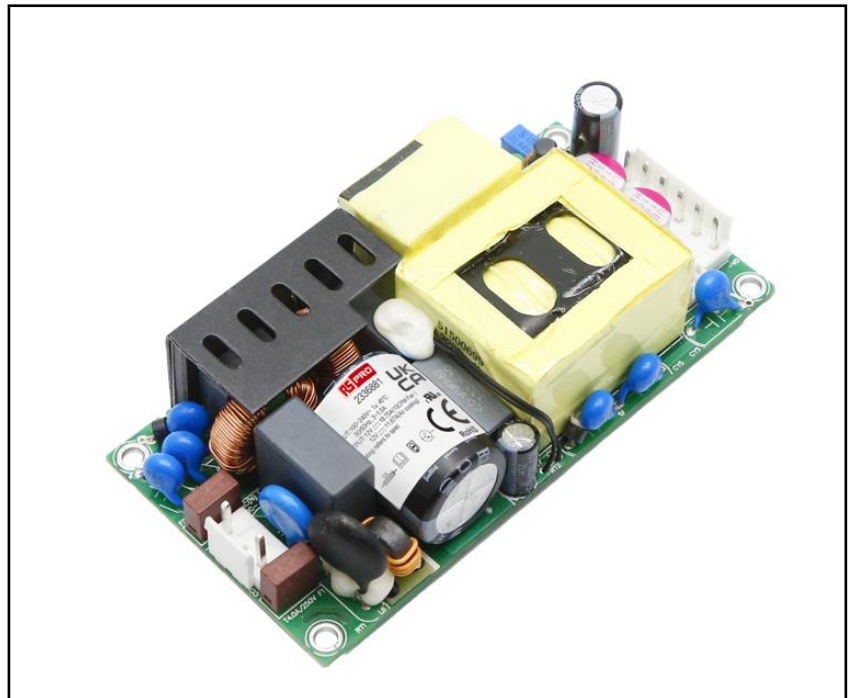

RS Professionally Approved Products bring to you professional quality parts across all product categories. Our product range has been tested by engineers and provides a comparable quality to the leading brands without paying a premium price.

Product Description

Embedded Switch Mode Power Supplies (SMPS)

AC-DC open frame power supply suitable for a wide range of Industrial, Medical and Dental applications. Featuring a universal AC input this cost-effective, high density design is available in a range of standard outputs. Complying with International and European EMC and safety standards IEC/EN/UL62368, GB4943, IEC/EN60335, IEC/EN61558, IEC/EN60601

General Specifications

Model	AC-DC 225W Medical / Industrial power supply
Mounting Type	Chassis Mount
MTBF	MIL-HDBK-217F@25°C > 300,000 h
Applications	Industrial control systems, instrumentation and medical equipment

RS Stock#	Input Voltage	Output Voltage	Adj'range (V)	Output Current	Wattage	Efficiency (Typ)
233-6881	85 to 264V ac 120 to 370V dc	12V DC	11.8-12.6	11.67A (Free air)	140W	93%
				18.75A (13CFM)	225W	
233-6883	85 to 264V ac 120 to 370V dc	24V DC	23.5-25.2	5.83A (Free air)	140W	94%
				9.4A (13CFM)	225W	
233-6886	85 to 264V ac 120 to 370V dc	48V DC	47.1-50.4	2.91A (Free air)	120W	94%
				4.7A (13CFM)	225W	

Input Specifications

Input Specification	
Voltage Range	85 to 264V ac, 120 to 370V dc
Frequency	47 to 63Hz
AC Current Rating	3A/115V ac, 2A/230V ac
Inrush Current	40A/ 115V ac, 75A / 230V ac
Leakage	<0.1mA, single fault <0.5mA
Power Factor	0.99 115Vac, 0.95 230Vac
Standby power consumption	0.5W

Output Specifications

Output Specification			
RS Stock No	233-6881	233-6883	233-6886
Output voltage	12V	24V	48V
Adjustment range	11.8-12.6V	23.5-25.2V	47.1-50.4V
Rated Current (13CFM)	18.75	9.4A	4.7A
Ripple & Noise (max.) *	60mVp-p	100mV	200mV
Rated Power (13CFM)	225W	225W	225W
Line Regulation typ.	±0.5%	±0.5%	±0.5%
Load Regulation typ.	±0.5%	±0.5%	±0.5%
Max Capacitive load μ F	6000 μ F	3200 μ F	1600 μ F
Minimum Load	0%	0%	0%
Fan Power	12V 0.5A with output voltage accuracy \pm 15%		

Hold Up Time	16ms/230V ac
Over Voltage Protection	12V output \leq 16V (Output voltage turn off, re-power on for recover) 24V output \leq 32V (Output voltage turn off, re-power on for recover) 48V output \leq 60V (Output voltage turn off, re-power on for recover)
Over-current Protection	\geq 130% I_o , hiccup, self-recovery
Short Circuit Protection	Hiccup, continuous, self-recovery
Isolation	4KVAC

Notes: 1. *Output voltage accuracy: including the setting error, line regulation, load regulation. 2. *The "Tip and barrel method" is used for ripple and noise test, output parallel 10 μ F electrolytic capacitor and 0.1 μ F ceramic capacitor, please refer to AC-DC Converter Application Notes for specific information. 3. *When the product works at light load (\leq 15% I_o), in order to improve the efficiency to reach at green working mode, the value of ripple and noise will be double. 4. *For all the above test items, please refer to our company standard "AC-DC Black Box Test Specification" for specific test specifications and methods

Embedded Switch Mode Power Supplies (SMPS)

General Specifications

Item	Operating Conditions		Min	Typ	Max.	Unit	
Isolation	Input-output	Electric Strength Test for 1min, leakage current <10mA	4000	-	-	VAC	
	Input-Earth	Electric Strength Test for 1min, leakage current <10mA	1500	-	-		
	Output-Earth	Electric Strength Test for 1min, leakage current <5mA	1500	-	-		
Insulation Resistance	Input-Earth	500VDC, 25±5 °C,	50	-	-	MΩ	
	Input-output	Humidity < 95%RH, non-condensing	50	-	-		
	Output-Earth	500VDC	50	-	-		
Isolation level	Input-output		2 × MOPP				
	Input-Earth		1 × MOPP				
	Output-Earth		1 × MOPP				
Operating Temperature		-40	-	+70	°C		
Storage Temperature		-40	-	+85			
Storage Humidity	Non-condensing		10	-	95	%RH	
Operating Humidity			20		90		
Power Derating	Operating temperature derating	Air cooling	+45 °C to +70 °C	2.0	-	-	% / °C
		13CFM	+50 °C to +70 °C	2.5	-	-	
			-40 °C to -30 °C	2.0			
	Input voltage derating	85-115VAC	1.0	-	-	%/VAC	
Safety Standard			Meet IEC/EN/UL62368-1 EN60335-1 IEC/EN61558-1, GB4943-1 IEC/EN60601-1/ES60601-1(3.1 version) CAN/CSA-C22.2 No.60601-1:14-Edition				
Safety Certification			IEC/EN/UL62368-1 EN60335/EN61558/ EN60601				
Safety Class			CLASS I (PE and must be connected)				
MTBF		MIL-HDBK-217F@25°C		> 300,000 h			

Embedded Switch Mode Power Supplies (SMPS)

Derating

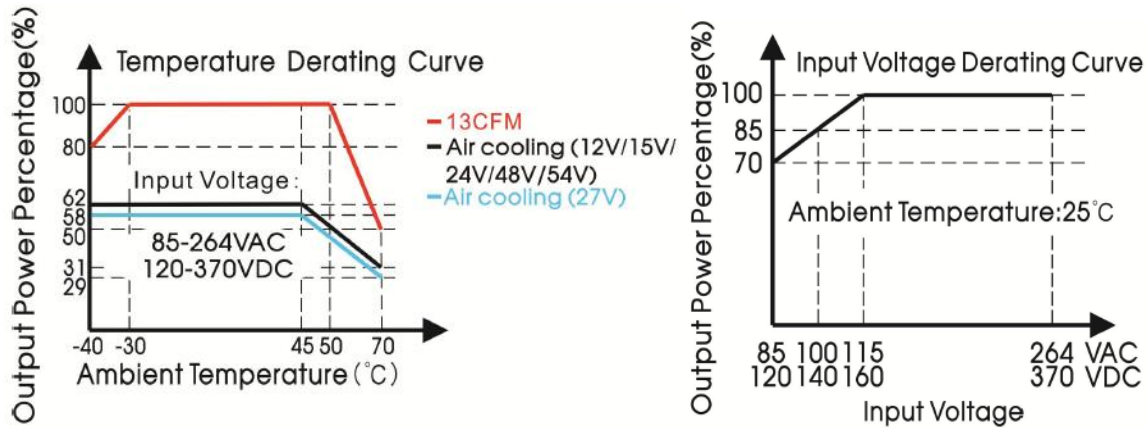

EMC Specifications

Emissions	CE	CISPR32/EN55032 CLASS B	
	RE	CISPR32/EN55032 CLASS B	
	Harmonic Current	IEC/EN61000-3-2 CLASS D	
Immunity	ESD	IEC/EN 61000-4-2 Contact ±8KV/Air ±15KV	Perf. Criteria A
	RS	IEC/EN 61000-4-3 10V/m	Perf. Criteria A
	EFT	IEC/EN 61000-4-4 ±4KV	Perf. Criteria A
	Surge	EC/EN 61000-4-5 ±2KV/±4KV	Perf. Criteria A
	CS	IEC/EN61000-4-6 10 Vr.m.s	Perf. Criteria A
	Voltage dips, short interruptions and voltage variations immunity	IEC/EN61000-4-11 0%, 70%	Perf. Criteria B

Note: 1.*The power supply should be considered as a part of the components in the system. All EMC performance has been tested on a metal plate with a thickness of 1mm and a length of 360mm x 360mm. The power supply must be combined with the terminal equipment for electromagnetic compatibility confirmation. 2.*Category I products with PE (which must be connected)

Embedded Switch Mode Power Supplies (SMPS)

Mechanical Specifications

Case Material	Open Frame
Dimensions	101.6 x 50.8 x 25.4mm
Weight	175g (Typ.)
Cooling Method	Air cooling / 13CFM

Dimensions and recommended layout

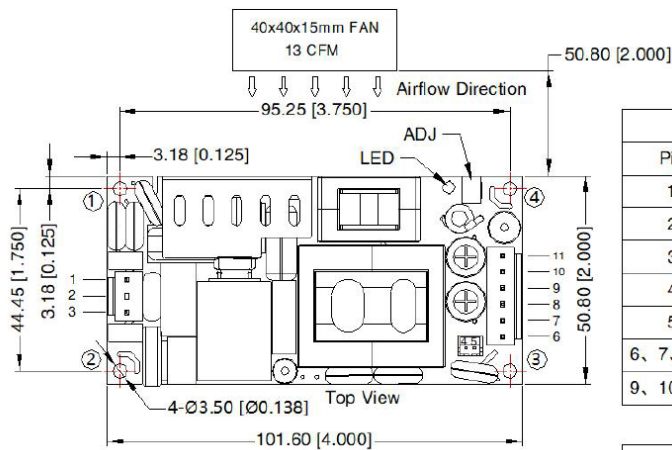

THIRD ANGLE PROJECTION

Pin-Out			
Pin	Function	Product Connector	Customer Connector
1	AC(N)/DC-	JST B3P-VH or equivalent	Housing: JST VHR Terminal: JST SVH-21T-P1.1 or equivalent
2	NC		
3	AC(L)/DC+	JST B2B-PH-K-S or equivalent	Housing: JST PHR-2 Terminal: JST SPH-002T-P0.5S or equivalent
4	Fan-		
5	Fan+	JST B6P-VH or equivalent	Housing: JST VHR Terminal: JST SVH-21T-P1.1 or equivalent
6, 7, 8	-Vo		
9, 10, 11	+Vo		

Position	Screw Spec.	L(Recommend)	Torque(max)
① - ④	M3	6mm	0.4N·m

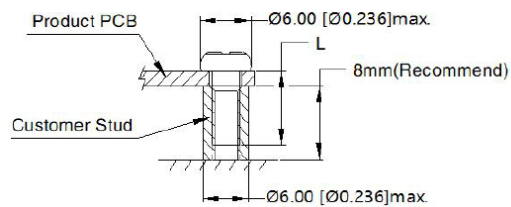
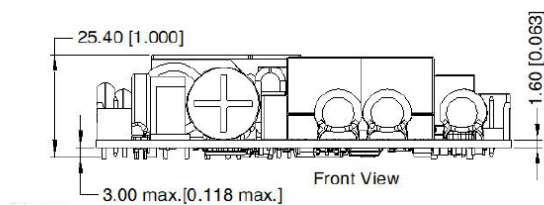

Embedded Switch Mode Power Supplies (SMPS)

Note:

1. Unit: mm[inch]
2. ADJ: Output adjustable resistor
3. General tolerances: $\pm 1.00[\pm 0.039]$
4. Do not use fan power to power other devices
5. The layout of the device is for reference only, please refer to the actual product
6. Reserved safety distance between PCB edge and customer components, recommended 10mm
7. Class I system ①, ③ positions must be connected to the earth(\perp)
8. Class II system ①, ③ positions must be connected together

Approvals

Safety Standard	IEC/EN/UL62368-1, EN60335-1, IEC/EN61558-1, GB4943-1, IEC/EN60601-1, ES60601-1(3.1 version), CAN/CSA-C22.2 No.60601-1:14-Edition 3, EN60601-1-2 Edition 4
Safety Certification	IEC/EN/UL62368-1, EN60335, IEC61558, UL/EN60601
Safety Class	Class I (PE and must be connected)

Note:

1. Unless otherwise specified, parameters in this datasheet were measured under the conditions of $T_a=25^{\circ}\text{C}$, humidity<75%RH with nominal input voltage and rated output load.
2. All index testing methods in this datasheet are based on our company corporate standards.
3. In order to improve the efficiency at high input voltage, there will be audible noise generated, but it does not affect product performance and reliability.
4. Products are related to laws and regulations: see "Features" and "EMC".
5. Our products shall be classified according to ISO14001 and related environmental laws and regulations and shall be handled by qualified units.
6. CAUTION: Double pole, neutral fusing. Disconnect mains before servicing."/"/ ATTENTION: Double pôle/fusible sur le neutre. Débrancher l'alimentation avant l'entretien;
7. The power supply is considered a component which will be installed into a terminal.