

82-11-520-XX	.547	.665	.815	-	-	-	
82-11-500-XX	.527	.645	.795	82-11-1000-XX	1.027	1.145	1.295
82-11-480-XX	.507	.625	.775	82-11-980-XX	1.007	1.125	1.275
82-11-460-XX	.487	.605	.755	82-11-960-XX	.987	1.105	1.255
82-11-440-XX	.467	.585	.735	82-11-940-XX	.967	1.085	1.235
82-11-420-XX	.447	.565	.715	82-11-920-XX	.947	1.065	1.215
82-11-400-XX	.427	.545	.695	82-11-900-XX	.927	1.045	1.195
82-11-380-XX	.407	.525	.675	82-11-880-XX	.907	1.025	1.175
82-11-360-XX	.387	.505	.655	82-11-860-XX	.887	1.005	1.155
82-11-340-XX	.367	.485	.635	82-11-840-XX	.867	.985	1.135
82-11-320-XX	.347	.465	.615	82-11-820-XX	.847	.965	1.115
82-11-300-XX	.327	.445	.595	82-11-800-XX	.827	.945	1.095
82-11-280-XX	.307	.425	.575	82-11-780-XX	.807	.925	1.075
82-11-260-XX	.287	.405	.555	82-11-760-XX	.787	.905	1.055
82-11-240-XX	.267	.385	.535	82-11-740-XX	.767	.885	1.035
82-11-220-XX	.247	.365	.515	82-11-720-XX	.747	.865	1.015
82-11-200-XX	.227	.345	.495	82-11-700-XX	.727	.845	.995
82-11-180-XX	.207	.325	.475	82-11-680-XX	.707	.825	.975
82-11-160-XX	.187	.305	.455	82-11-660-XX	.687	.805	.955
82-11-140-XX	.167	.285	.435	82-11-640-XX	.667	.785	.935
82-11-120-XX	.147	.265	.415	82-11-620-XX	.647	.765	.915
82-11-100-XX	.127	.245	.395	82-11-600-XX	.627	.745	.895
82-11-080-XX	.107	.225	.375	82-11-580-XX	.607	.725	.875
82-11-060-XX	.087	.205	.355	82-11-560-XX	.587	.705	.855
82-11-040-XX	.067	.185	.335	82-11-540-XX	.567	.685	.835
PART NUMBER	"U"	"L"	"F"	PART NUMBER	"U"	"L"	"F"

REVISION HISTORY			
REV	DATE	BY	DESCRIPTION
C	17JUN2019	CB1/DMS	PRN: P2019-1472

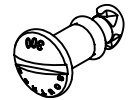

SCALE 1:1

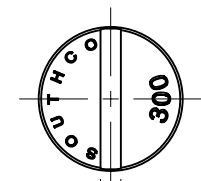

SLOT
.05 WIDE X .05 DEEP

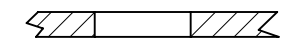
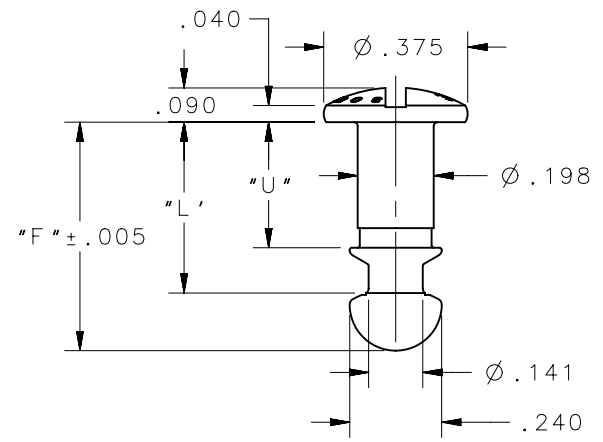

$\phi .250$ $+ .005$
 $- .002$

SUGGESTED PANEL PREPARATION

NOTES:

- MATERIAL:
XX= -16, -52, -31, -17, :
1008 STEEL, CASE HARDENED
= -20, -43 STAINLESS STEEL
- FINISH (-XX):
-16 ZINC PLATE, CHROMATE, PLUS SEALER
-17 ZINC PLATE, YELLOW CHROMATE
-20 PASSIVATED
-31 BLACK OXIDE
-43 NATURAL
-52 BLACK POWDER COATING
- PART NO. 82-11-300-XX SHOWN.

82-11-YYYY-XX	STUD	SEE NOTE A	SEE NOTE B
SOUTHCO PART NUMBER	TYPE OF COMPONENT	MATERIAL	FINISH
CPB NUMBER	THIRD ANGLE PROJECTION	 CONNECT • CREATE • INNOVATE	
	INCHES [MM]		
SURFACE AREA	TOLERANCES UNLESS OTHERWISE NOTED	DESCRIPTION SOUTHCO NO. 82 STUD FASTENER, OVAL HEAD	
VOLUME	ALL DIMENSIONS WITHOUT TOLERANCES ARE FOR REFERENCE ONLY.	SIZE A	SYSTEM NX
PROPRIETARY ITEM <small>EXCEPT FOR USES EXPRESSLY GRANTED IN WRITING, INFORMATION DISCLOSED HEREON IS CONFIDENTIAL AND ALL RIGHTS, PATENT AND OTHERWISE, ARE RESERVED BY SOUTHCO, INC.</small>	PER ASME Y14.5M-1994	DWG NO. J-82-11-1	
		DRAWN BY MDM/CHW	DATE 11JUN1999
		SCALE 2:1	SHEET 1 OF 1