

MAX16137 Evaluation Kit

Evaluates: MAX16137

General Description

The MAX16137 evaluation kit (EV kit) is designed to evaluate the MAX1613700/VY+, a 1% accuracy, window-detector supervisory reset IC with BIST (Built-In-Self-Test) capability and overvoltage fault output in an 8-pin TDFN package. Several test points are provided to facilitate device evaluation. The EV kit is fully assembled and tested over the automotive temperature range of -40°C and +125°C and is available with the MAX1613700/VY+ installed.

Features

- 1.71V to 5.5V Supply Voltage Range
- Push-Button Switch to Clear \overline{OV} Latch
- Proven 2-Layer 2oz Copper PCB Layout
- Automotive Temperature Range: -40°C and +125°C
- Demonstrates Compact Solution Size
- Fully Assembled and Tested

Ordering Information appears at end of data sheet.

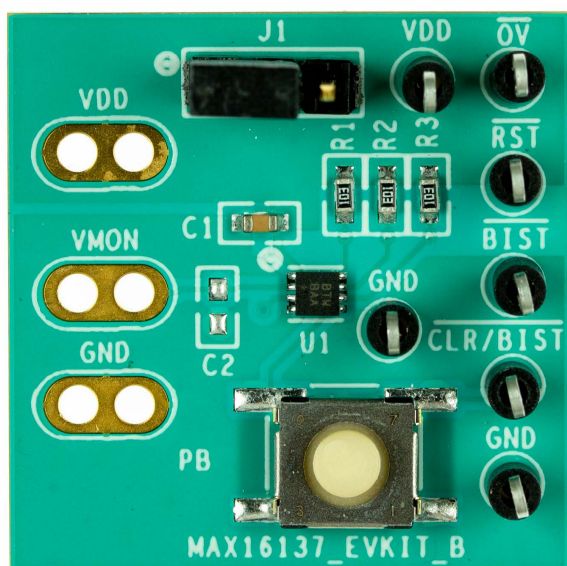

Figure 1. MAX16137EV Kit Board

Quick Start

Required Equipment

- MAX16137 EV kit
- 5V DC power supply (X2)
- One Digital Multimeter (DMM)
- 4-Channel Scope Oscilloscope

Procedure

The EV kit is fully assembled and tested. Follow these steps to verify the board operation:

CAUTION: Do not turn on the power supply until all connections are completed.

- 1) Verify the shunts are installed onto their respective default positions for jumper J1 ([Table 1](#)).
- 2) Connect one of the 5V power supplies between the VDD and GND terminal posts.
- 3) Connect the other 5V power supply between the VMON and GND terminal posts.
- 4) Connect the DMM between the VMON and GND posts.
- 5) Connect the channel 1 of the oscilloscope to \overline{RST} , channel 2 of the oscilloscope to \overline{OV} , channel 3 of the oscilloscope to $\overline{CLR/BIST}$, and channel 4 of the oscilloscope to BIST of the EV kit.
- 6) Turn on the power supply.
- 7) Manually increase the power supply connected from VDD to GND to 5V.
- 8) Manually increase the power supply connected from VMON to GND to 3.3V. Verify the \overline{RST} , \overline{OV} , and $\overline{CLR/BIST}$ traces on the scope pulled up to 5V.
- 9) Slowly increase the VMON voltage while monitoring the voltage on the DMM. When the VMON reading on DMM is past 3.530V, \overline{RST} and \overline{OV} should assert low while $\overline{CLR/BIST}$ and BIST are pulled up to 5V pullup supply.
- 10) Slowly bring VMON voltage below 3.530V and verify \overline{RST} deasserts while \overline{OV} is latched low.
- 11) Push the PB switch momentarily to ground and verify \overline{OV} latch is cleared. The EV kit is ready for further evaluation. Refer to the device data sheet for specifications and functional details.

Detailed Description

The MAX16137 evaluation kit evaluates the MAX1613700/VY+, a 1% accuracy, window-detector supervisory reset IC with BIST (Built-In-Self-Test) capability and overvolt-age fault output. \overline{OV} , \overline{RST} , and \overline{BIST} are open-drain outputs pulled up to VDD with external resistors. An optional capacitor (C2) provides additional filtering capability for the monitoring and a jumper (J1) facilitates configuration of the BIST during normal operation.

CLR/BIST Push-Button Switch

The EV kit includes a push button switch to clear the over-voltage latched output when the input exceeds the

overvoltage threshold. The overvoltage fault is clear on the falling edge of the $\overline{CLR/BIST}$ signal. Also, the push-button switch allows the MAX16137 to perform BIST operation during normal operation with the $\overline{CLR/BIST}$ voltage pulled low for more than 150 μ s(min). See [Table 1](#) and the device data sheet for more details.

NR Jumper (J1)

Jumper (J1) allows the MAX16137 to perform BIST either by pulling \overline{RST} low or without pulling \overline{RST} low during normal operation after power-up. See [Table 1](#) for the jumper setting.

Table 1. NR (J1)

JU1 SHUNT POSITION	DESCRIPTION
Installed*	$V_{NR} = VDD$ (through pullup resistor R1). BIST is completed without the device pulling \overline{RST} low when performing BIST during normal operation.
Not Installed	$V_{NR} = GND$ (through pulldown resistor R2). BIST is completed with device pulling \overline{RST} low when performing BIST during normal operation.

*Default position.

Component Suppliers

SUPPLIER	PHONE NUMBER	WEBSITE
Murata	770-436-1300	www.murata.com
TDK	847-803-6100	www.component.tdk.com
Panasonic	800-344-2112	www.panasonic.com

Note: Indicate using the MAX16137 when contacting these component suppliers.

Ordering Information

PART	TYPE
MAX16137EVKIT#	EV Kit

#Denotes RoHS

MAX16137 EV Kit Bill of Materials

DESIGNATION	QTY	DESCRIPTION
C1	1	0.1 μ F \pm 10%, 100V X7R ceramic capacitors (1206) Murata: GRM31CR72E104KW03, GRM319R72A104KA01 TDK: C3216X7R2A104K160AA
C2	1	Not installed, capacitor (0603)
VDD, VMON, GND	3	20G tinned copper bus wire from/into "U" shaped loops (0.25in off the PCB)
VDD, \overline{OV} , \overline{RST} , \overline{BIST} , $\overline{CLR/BIST}$, GND (X2)	7	Test points Vero Technologies
J1	1	2-pin headers, 0.1in centers
PB	1	15V, 20mA 100 Ω SPST push-button switch Panasonic: EVQ-Q2K03W
R1-R3	1	10k Ω \pm 5% (0603)
U1	1	MAX1613700/VY+
-	1	Shunts
-	1	PCB: MAX16137 EVALUATION KIT

MAX16137 EV Kit Schematic

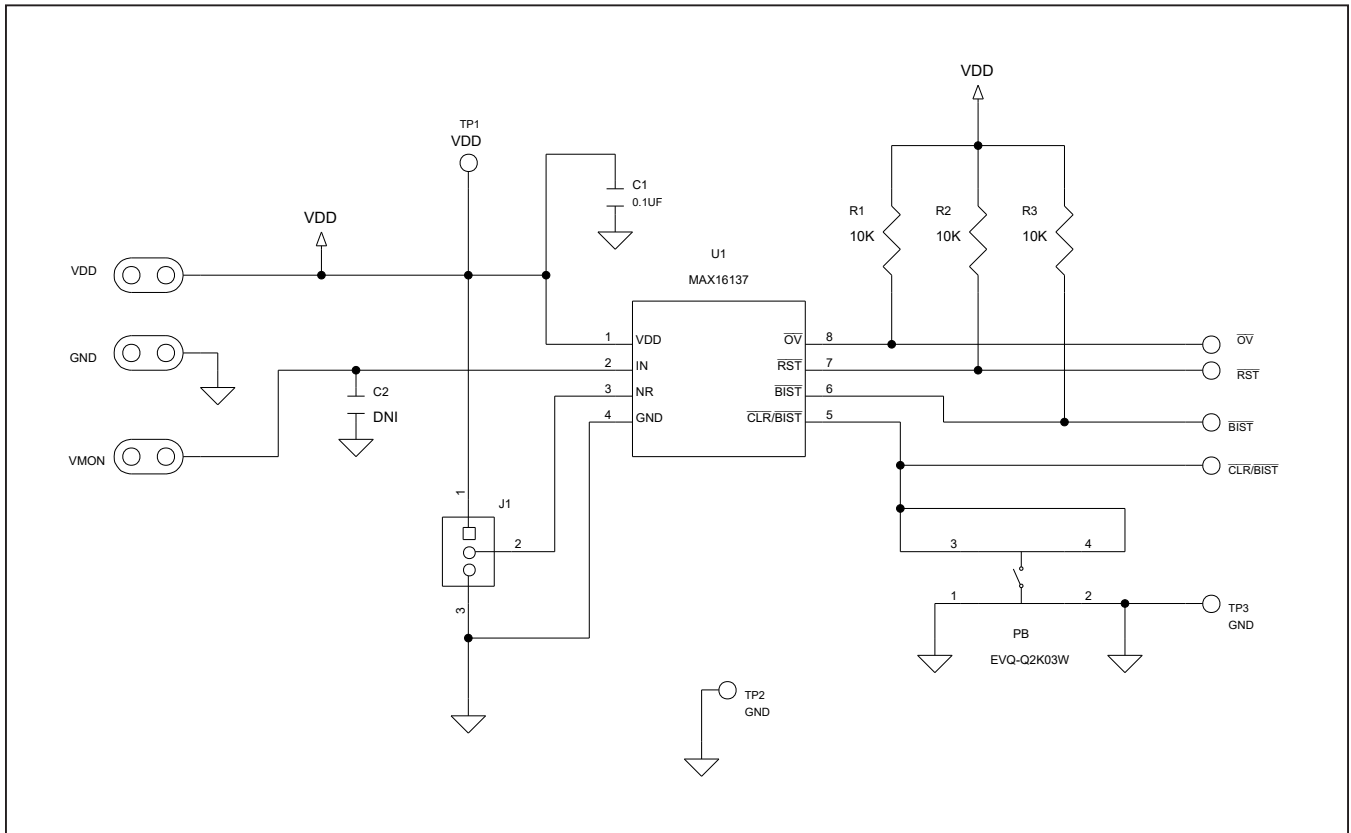

Figure 2. MAX16137EV Kit Schematic

MAX16137 EV Kit PCB Layouts

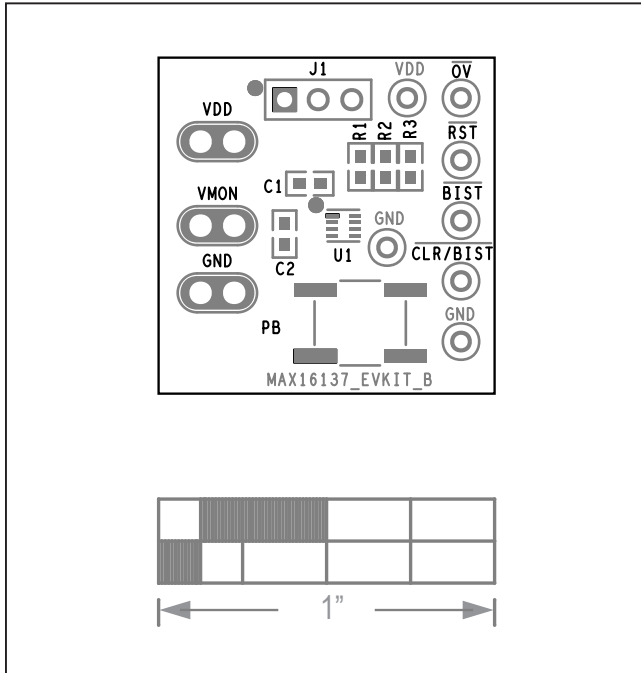

Figure 3. MAX16137 EV Kit—Top Silkscreen

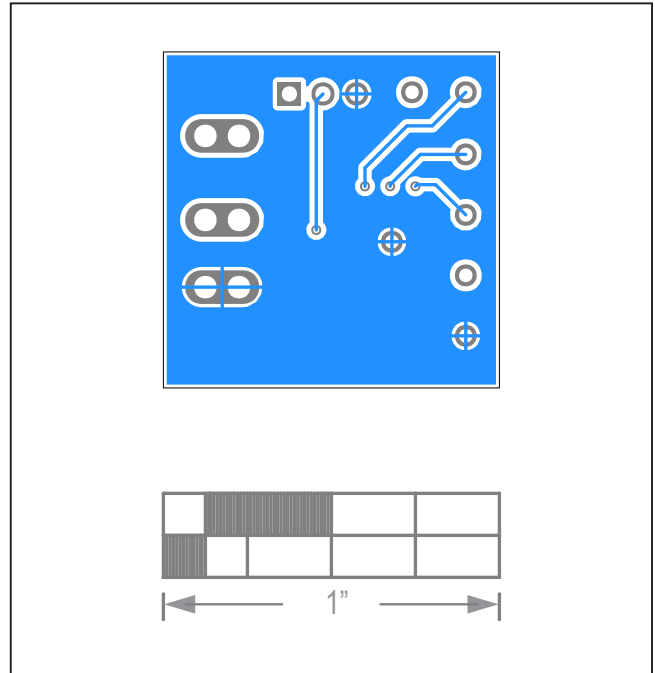

Figure 5. MAX16137 EV Kit—Bottom View

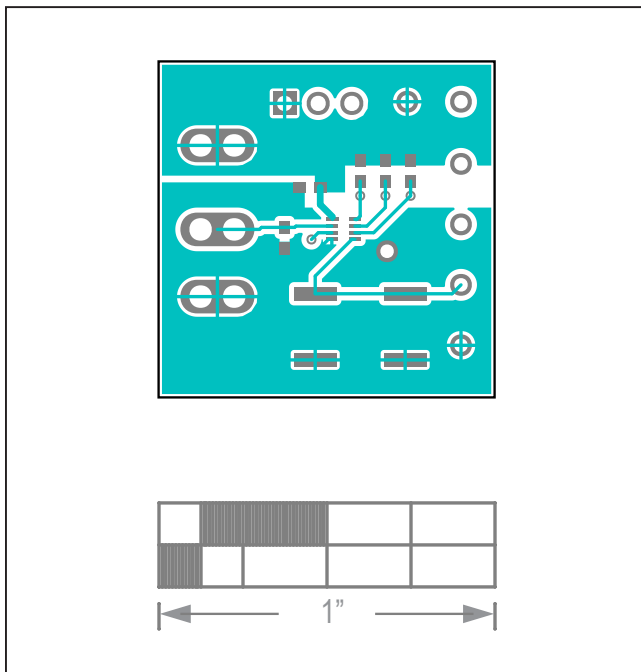

Figure 4. MAX16137 EV Kit—Top View

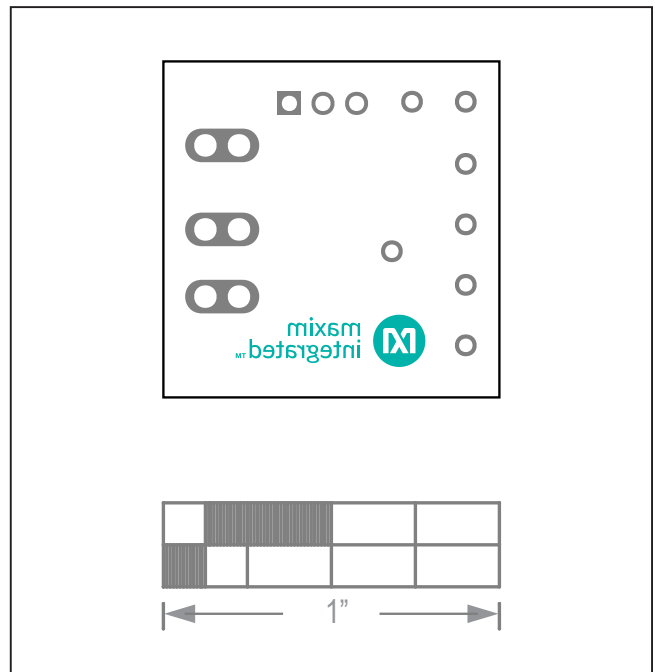

Figure 6. MAX16137 EV Kit—Bottom Silkscreen

Revision History

REVISION NUMBER	REVISION DATE	DESCRIPTION	PAGES CHANGED
0	2/21	Initial release	—

For pricing, delivery, and ordering information, please visit Maxim Integrated's online storefront at <https://www.maximintegrated.com/en/storefront/storefront.html>.

Maxim Integrated cannot assume responsibility for use of any circuitry other than circuitry entirely embodied in a Maxim Integrated product. No circuit patent licenses are implied. Maxim Integrated reserves the right to change the circuitry and specifications without notice at any time.