

NO	DESCRIPTION	DATE
1	BACKGROUND FORMAT UPDATED	09.29.08'
2	DEL CABLE RETENTION	06.17.10'
3	DEL INTERFACE	08.04.11'
4	DEL PROOF VOLTAGE ; ADD VSWR WORKING VOLTAGE → VOLTAGE RATING	04.30.13'

TYPE	ID
A	$\phi 1^{+0.1}_{-0} < 0.039^{+0.04}_{-0} >$

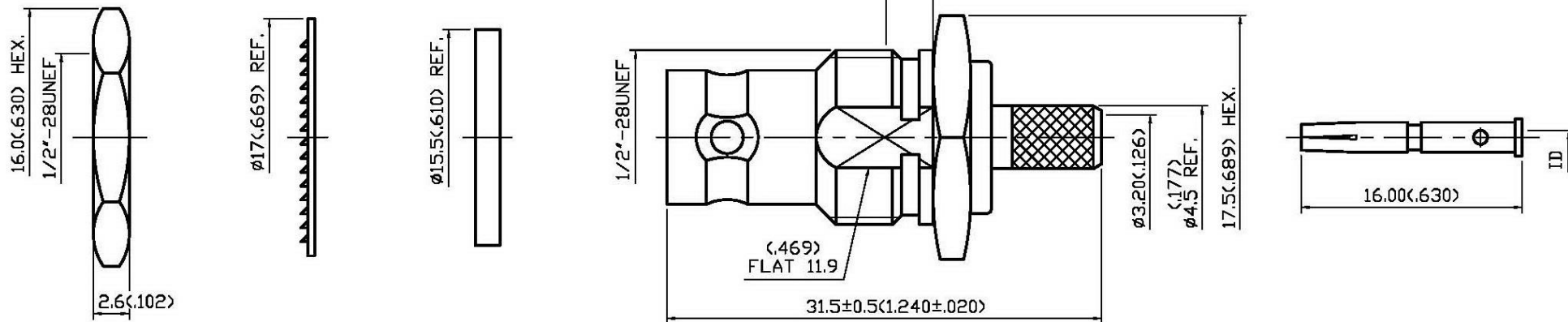

04/30/2013

1.0 ELECTRICAL

- 1.1 FREQUENCY RANGE: DC-4 GHz
- 1.2 NOMINAL IMPEDANCE: 50 OHMS
- 1.3 VOLTAGE RATING: 500 VOLTS MAX. \triangle
- 1.4 VSWR: 1.5 MAX. @ 3 GHz \triangle

2.0 MATERIALS

- 2.1 BODIES: BRASS PER JIS-C3604
- 2.2 CENTER CONTACT: BRASS PER JIS-C3604
- 2.3 INSULATION: TEFLON PER ASTM D1457 AND ASTM D1710
- 2.4 CRIMP FERRULE: BRASS PER JIS-C2700

3.0 FINISHES AND OTHERS

3.1 SEE BELOW TABLE FOR DETAILS.

4.0 MECHANICAL

- 4.1 FOR USE WITH RG58U OR SIMILAR STYLE CABLE
- 4.2 CABLE ATTACHMENT: OUTER: CRIMP, INNER: SOLDER/CRIMP
- 4.3 CRIMP SIZE REQUIRED: CONTACT: 1.8(071) HEX. CRIMP TOOL
FERRULE: 5.5(216) HEX. CRIMP TOOL

5.0 ENVIRONMENTAL

5.1 OPERATING TEMPERATURE RANGE: -85° C TO +185° C

NO	DESCRIPTION	MATERIAL	Q'TY	FINISH
8	CENTER CONTACT	BRASS	1	GOLD
7	CRIMP FERRULE	BRASS	1	NICKEL
6	CHASSIS	BRASS	1	NICKEL 100μ" MIN.
5	GASKET	SILICONE	1	NONE
4	INSULATION	TEFLON	1	NONE
3	BODY	BRASS	1	NICKEL 100μ" MIN.
2	WASHER	STEEL	1	NICKEL
1	NUT	BRASS	1	NICKEL

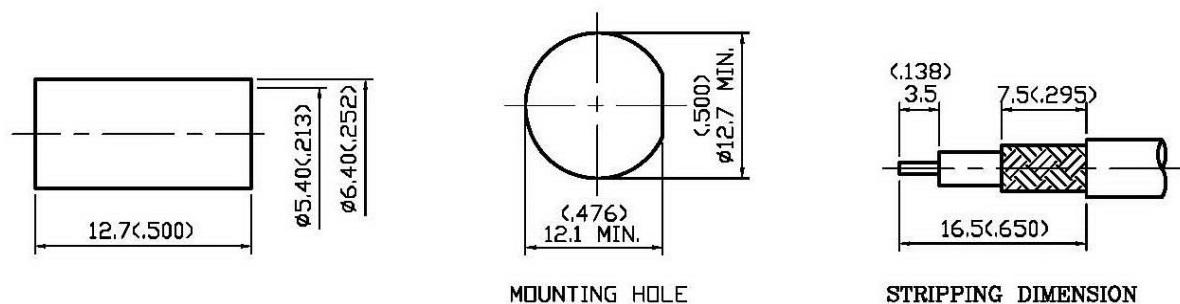

APPROVED by _____ DATE: _____



DESCRIPTION		BNC STRAIGHT BULKHEAD JACK CRIMP									
製圖	DRAWN	TOLERANCE	品名	13-11	T.G.N	58U	DATE	版次	REV.		
	<i>Kristina</i>	.X ±0.2	TITLE	\ ROHS COMPLIANT <50Ω>			日期	01.15.92'	B-4		
檢圖	CHECK	.XX ±0.1	單位	mm(h)	DWG.NO.	13-0106					
	<i>Ivan</i>	.XXX ±0.05	比例	SCALE							
認定	APPROVAL	ANGLE ±5°	比例	3:1							
	<i>Angela</i>										