

Dimensions :- Metric (Inch)

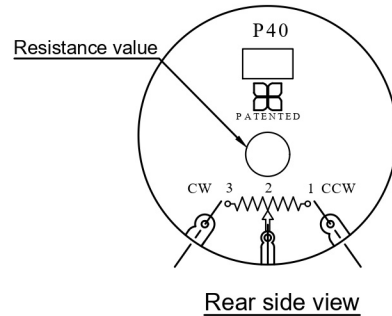
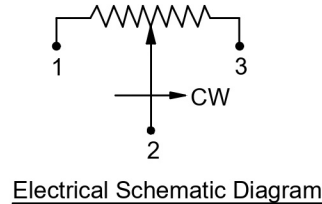
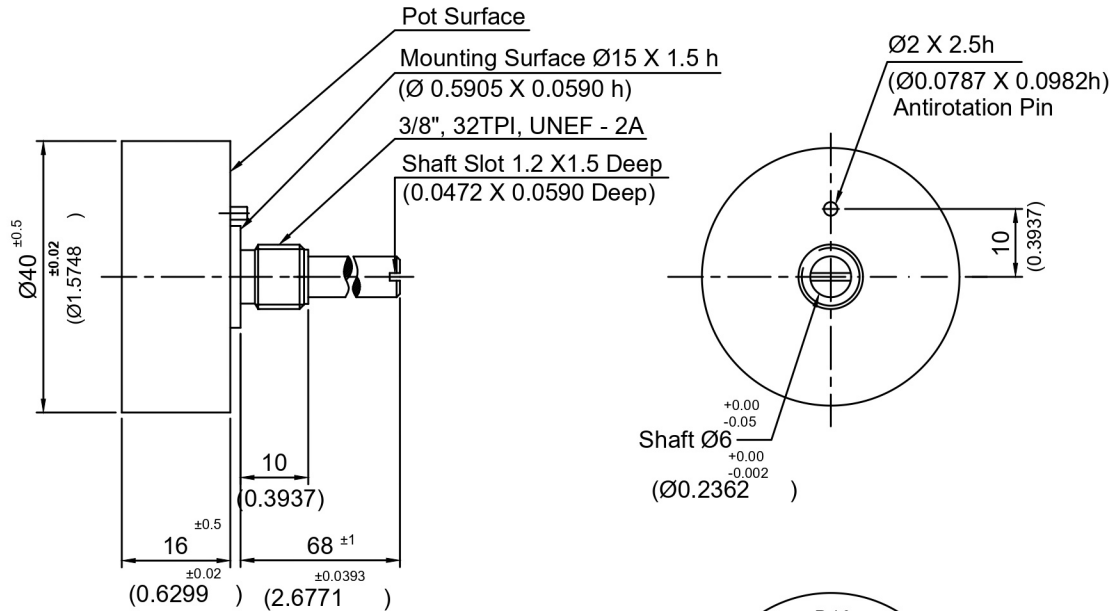

ELECTRICAL CHARACTERISTICS	UNITS	VALUE
Resistance Element.....	--	Wire Wound
Resistance value	Ohms	1k,2k,5k,10k
Standard Resistance Tolerances.....	%	±10
Standard Independent Linearity Tolerances..(IEC 393)..	%	±0.75
Electrical angle.....	Degrees	270° ±5°
Equivalent Noise Resistances.....	Ohms	<100
Resolution.....	--	As per turns
Temperature Coefficient of Resistance (TCR).....	ppm/deg C	± 50 Up to 1k ohms ±150 for other values.
Power Rating @ 70° C.....	Watts	3
Insulation Resistance @ 500 Vdc.....	M Ohms	1000
Dielectric Strength @ 50 Hz.....	V ac	500
Maximum Wiper current.....	mAmps	1
Short time wiper current 10 sec.	mAmps	10
End Resistance	%	< 0.1 OR 5 Ohms which is higher

MECHANICAL CHARACTERISTICS :-		
Rotation (Mechanical Angle). With stop.....	Degrees	285° ±5°
Bearing Type.....	--	Sleeve
Torque... Starting.....	Nmm (Oz inch)	15 (2.124)
Torque... Running.....	Nmm (Oz inch)	10 (1.41)
Axial Play	m.m.(inch)	0.2 (0.00787)
Radial Play	m.m.(inch)	0.2 (0.00787)

ENVIRONMENTAL CHARACTERISTICS :-		
Operating Temperature.....	Degrees C	-40 to +105

PERFORMANCE :-		
Rotational Life (shaft Revolutions).....	Nos.	100,000

MATERIALS OF CONSTRUCTION:-		
Housing.....	--	Engineering Plastics
Shaft.....	--	Brass nickel plated
Terminals.....	--	Brass Silver plated
Mounting Hardware	--	Lock Washer-steel + Nut-Brass, A/F 14 X 3 mm, both Nickel plated
Bushing.....	--	Brass Nickel Plated

Soldering Recommendation :- Use soldering Iron at 350° C for 3 second maximum. Clean the soldered pads with Isopropyl alcohol after soldering. Continuous improvements are being made for enhancing performance for customer benefit in product design & process. The product supplied may be slightly different than described by above specifications



SINGLE TURN POTENTIOMETER WIRE WOUND

First Issue : 2010/01/25 Scale:- 1:1

Tolerances
DIN-ISO 2768-1 (1991-06)
(Tolerance class-medium)

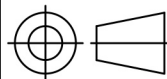

CUSTOMER DRAWING REF NO
NA

REV - 00

CUSTOMER : UAPL STANDARD

SHEET
1 of 1