

# ABLP1A24045

Regulated Power Supply, modicon power supply, 100...240V AC, 24V, 4.5A, single phase, Panel Mount

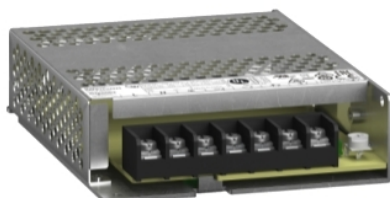

## Main

Range of product	Modicon Power Supply
Product or component type	Power supply
Power supply type	Regulated switch mode
Variant option	Panel mount
Enclosure material	Aluminium
Nominal input voltage	100...240 V AC single phase
Rated power in W	100 W
Output voltage	24 V DC
Power supply output current	4.5 A

## Complementary

Input voltage limits	90...264 V AC
Nominal network frequency	50...60 Hz
Network system compatibility	TN TT IT
Maximum leakage current	1 mA 240 V AC
Input protection type	Integrated fuse (not interchangeable) 4 A
Inrush current	45 A at 115 V 85 A at 230 V
Power factor	0.55 at 115 V AC 0.45 at 230 V AC
Efficiency	89 % at 230 V AC
Output voltage adjustment	21.6...26.4 V
Power dissipation in W	20 W
Current consumption	< 2.3 A 115 V AC < 1.5 A 230 V AC
Turn-on time	< 500 ms
Holding time	> 20 ms 115 V AC > 40 ms 230 V AC
Startup with capacitive loads	4000 µF
Residual ripple	< 150 mV
Meantime between failure [MTBF]	700000 h at 25 °C, full load conforming to SR 332
Output protection type	Against overload and short-circuits, protection technology: automatic reset Against over temperature, protection technology: manual reset Against overvoltage, protection technology: manual reset
Connections - terminals	Screw connection: 0.75...2.5 mm <sup>2</sup> , (AWG 18...AWG 14) without wire end ferrule Screw connection: 0.75...1.5 mm <sup>2</sup> , (AWG 18...AWG 16) with wire end ferrule
Line and load regulation	< 0.5 % at 0 to 100 % load at 25 °C < 1 % at full voltage range in line at 25 °C
Status LED	1 LED (green) output voltage
Depth	129 mm
Height	30 mm
Width	97 mm
Net weight	0.3 kg

The information provided in this documentation contains general descriptions and/or technical characteristics of the performance of the products contained herein. This documentation is not intended as a substitute for and is not to be used for determining suitability or reliability of these products for specific user applications. It is the duty of any such user or integrator to perform the appropriate and complete risk analysis, evaluation and testing of the products with respect to the relevant specific application or use thereof. Neither Schneider Electric Industries SAS nor any of its affiliates or subsidiaries shall be responsible or liable for misuse of the information contained herein.

Output coupling	Parallel Serial
Mounting support	Top hat type TH35-15 rail conforming to IEC 60715 Top hat type TH35-7.5 rail conforming to IEC 60715 Double-profile DIN rail Panel mounting
Supply	SELV conforming to IEC 60950-1 SELV conforming to IEC 60204-1 SELV conforming to IEC 60364-4-41
Dielectric strength	3750 V AC with input to output
Service life	10 year(s)
Overvoltage category	II

## Environment

Standards	IEC 62368-1 IEC 61010-1 EN 61010-2-201 EN 61204-3 IEC 61000-6-1 IEC 61000-6-2 IEC 61000-6-3 IEC 61000-6-4 IEC 61000-3-2 EN 61000-3-3 UL 62368-1 UL 61010-1 UL 61010-2-201 CSA C22.2 No 62368-1 CSA C22.2 No 61010-1 CSA C22.2 No 61010-2-201 EN/IEC 62368-1
Product certifications	CE[RETURN]CULus[RETURN]EAC[RETURN]RCM[RETURN]CB Scheme[RETURN]KC
Operating altitude	5000 m
Shock resistance	150 m/s <sup>2</sup> for 11 ms
IP degree of protection	IP10
Ambient air temperature for operation	-30...50 °C without derating mounting position A, B, F, G < 2000 m 50...70 °C with current derating of 2 % per °C mounting position A, B, F, G < 2000 m
Electrical shock protection class	Class I
Pollution degree	2
Vibration resistance	3 mm (f= 2...9 Hz) conforming to IEC 60068-2-6 10 m/s <sup>2</sup> (f= 9...200 Hz) conforming to IEC 60068-2-6
Electromagnetic immunity	Immunity to electrostatic discharge - test level: 8 kV (contact discharge) conforming to IEC 61000-4-2 Immunity to electrostatic discharge - test level: 15 kV (air discharge) conforming to IEC 61000-4-2 Immunity to conducted RF disturbances - test level: 15 V/m (80 MHz...2 GHz) conforming to IEC 61000-4-3 Immunity to conducted RF disturbances - test level: 5 V/m (2...2.7 GHz) conforming to IEC 61000-4-3 Immunity to conducted RF disturbances - test level: 5 V/m (2.7...6 GHz) conforming to IEC 61000-4-3 Immunity to fast transients - test level: 4 kV (on input-output) conforming to IEC 61000-4-4 Surge immunity test - test level: 4 kV (between power supply and earth) conforming to IEC 61000-4-5 Surge immunity test - test level: 3 kV (between phases) conforming to IEC 61000-4-5 Immunity to conducted RF disturbances - test level: 15 V (0.15...80 MHz) conforming to IEC 61000-4-6 Immunity to magnetic fields - test level: 30 A/m (50...60 Hz) conforming to IEC 61000-4-8 Immunity to voltage dips conforming to IEC 61000-4-11 Disturbing field emission conforming to EN 55016-2-3 Limits for harmonic current emissions conforming to IEC 61000-3-2 Conforming to EN 55016-1-2 Conforming to EN 55016-2-1
Electromagnetic emission	Conducted emissions conforming to IEC 61000-6-3 Radiated emissions conforming to IEC 61000-6-4

## Packing Units

Unit Type of Package 1	PCE
Number of Units in Package 1	1
Package 1 Height	4.000 cm
Package 1 Width	14.800 cm
Package 1 Length	18.500 cm
Package 1 Weight	421.000 g
Unit Type of Package 2	S03
Number of Units in Package 2	19
Package 2 Height	30.000 cm
Package 2 Width	30.000 cm
Package 2 Length	40.000 cm
Package 2 Weight	8.400 kg

## Offer Sustainability

Sustainable offer status	Green Premium product
REACH Regulation	<a href="#">REACH Declaration</a>
EU RoHS Directive	Pro-active compliance (Product out of EU RoHS legal scope)
Mercury free	Yes
China RoHS Regulation	<a href="#">China RoHS Declaration</a>
RoHS exemption information	<a href="#">Yes</a>
Environmental Disclosure	<a href="#">Product Environmental Profile</a>
Circularity Profile	<a href="#">End Of Life Information</a>
WEEE	The product must be disposed on European Union markets following specific waste collection and never end up in rubbish bins

Electrical Safety

- If the unit is use in a manner not specified by the manufacturer, the protection provided by the equipment may be impaired.
- For means of disconnection a switch or circuit breaker, located near the product, must be included in the installation. A marking as disconnecting device for the product is required.
- The device has an internal fuse. The unit is tested and approved with branch circuit protective device up to 20A. This circuit breaker can be used as disconnecting device.
- The power supply is only suitable for audio, video, information, communication, industrial and control equipment.

Dimensions

Front and Side Views

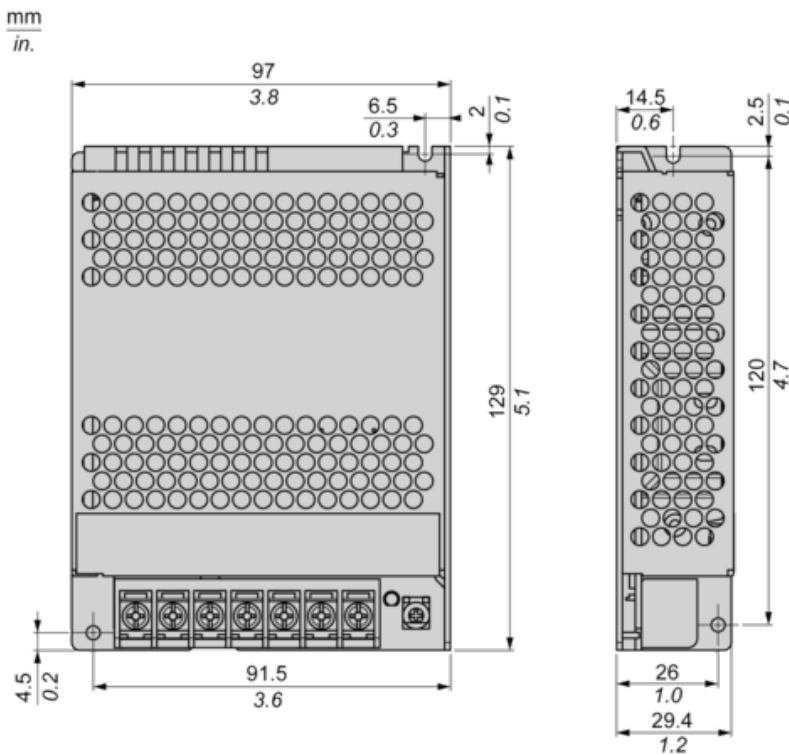

Connections and Schema

Correct Parallel Connection

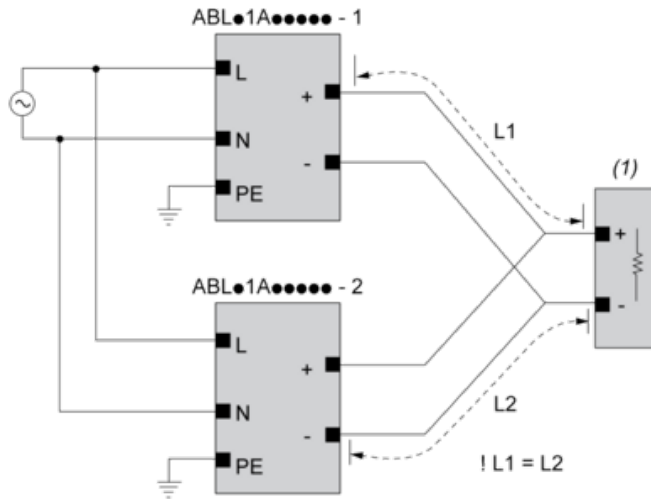

(1) : Load

Incorrect Parallel Connection

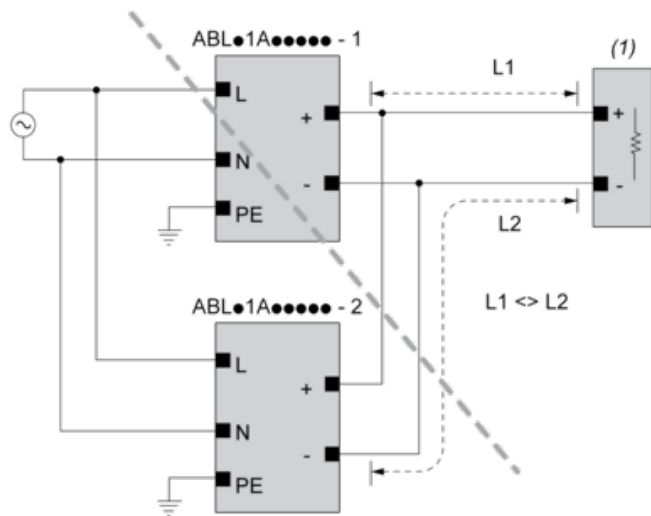

(1) : Load

ABLx1Axxxxx-1 = ABLx1Axxxxx-2

max 2 x ABLx1Axxxxx

L1 = L2

$\Delta V$  max 25 mV

$I_{Load} < 90\% \cdot 2 \cdot I_{nom}$

## Output Voltage Balancing

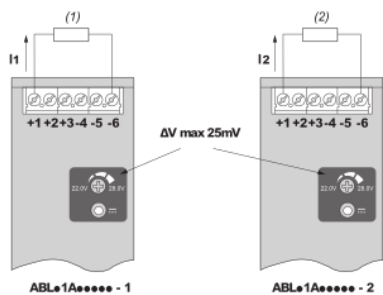

(1) :  $R_{Load1}$

(2) :  $R_{Load2}$

$R_{Load1} = R_{Load2}$

$I_1 = I_2 = \sim I_{nom}$

## Series Connection

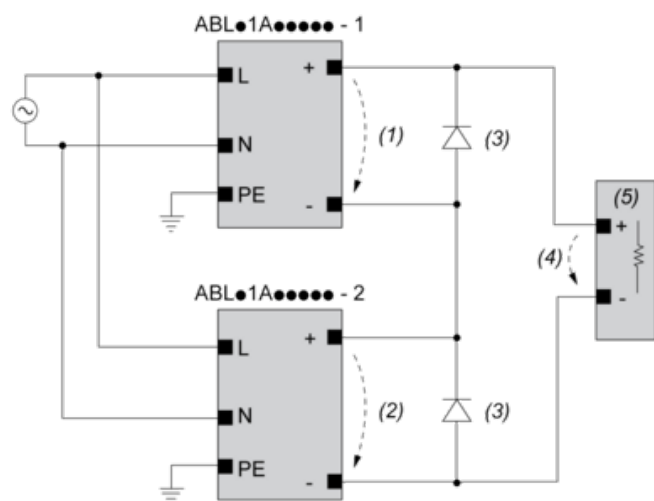

(1) :  $V_{out1}$

(2) :  $V_{out2}$

(3) : 2 x Diode,  $V_{RRM} > 2 \times V_{out1/2}$ ,  $I_F > 2 \times I_{nom1/2}$

(4) :  $V_{Load} = 2 \times V_{out}$

(5) : Load

## Connections and Schema

	(1)		
	<40°C	<50°C	<70°C
ABLP1A12085	60°C	70°C	90°C
ABLP1A24045	60°C	70°C	90°C
ABLP1A24062	60°C	70°C	90°C
ABLP1A24100	60°C	70°C	90°C

(1) : Ambient

Mounting

Mounting Position A

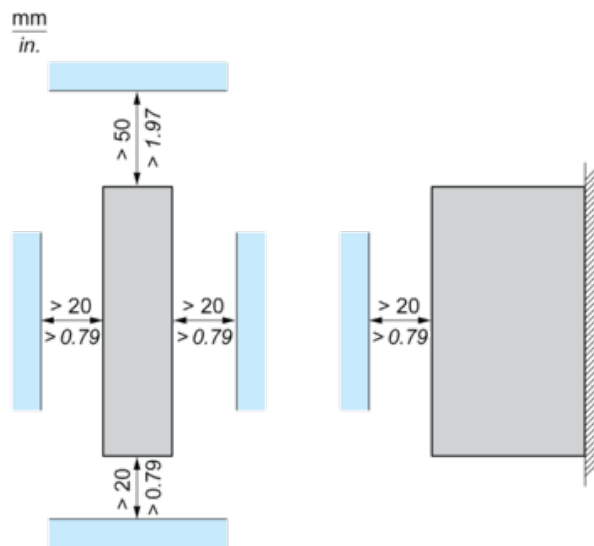

Mounting Position B

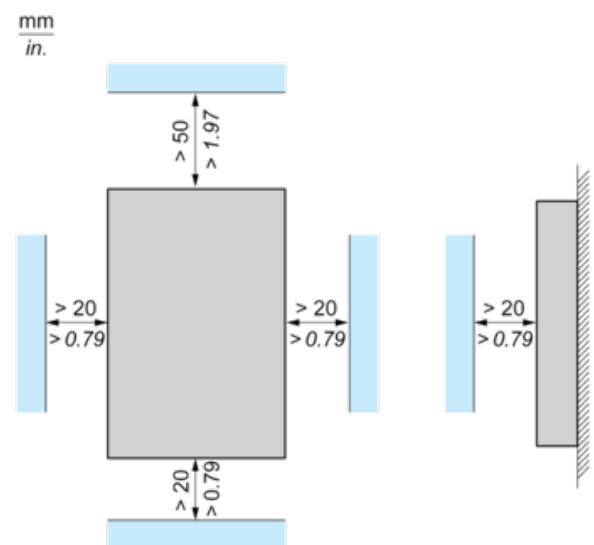

Mounting Position C

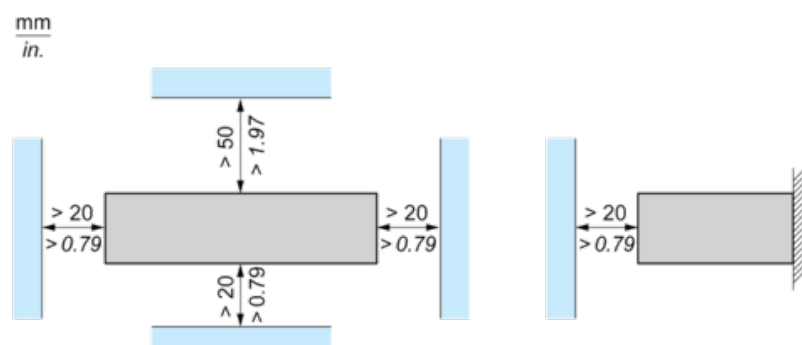

### Mounting Position F

$\frac{\text{mm}}{\text{in.}}$

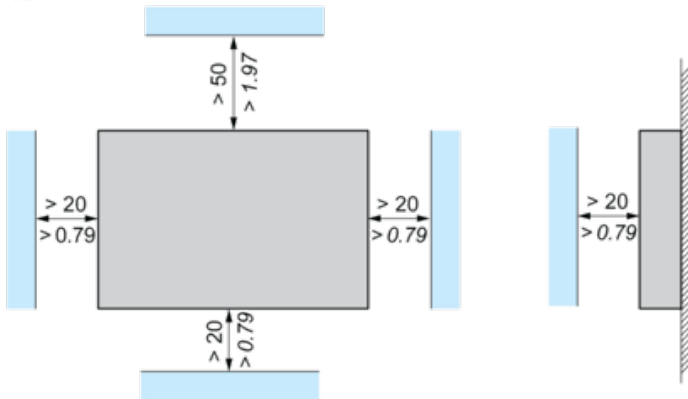

### Mounting Position G

$\frac{\text{mm}}{\text{in.}}$

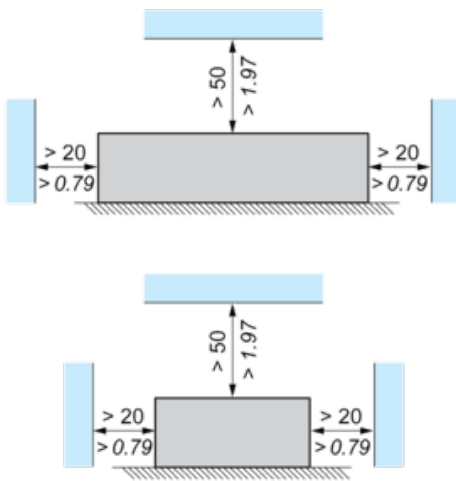

### Mounting Position H

$\frac{\text{mm}}{\text{in.}}$

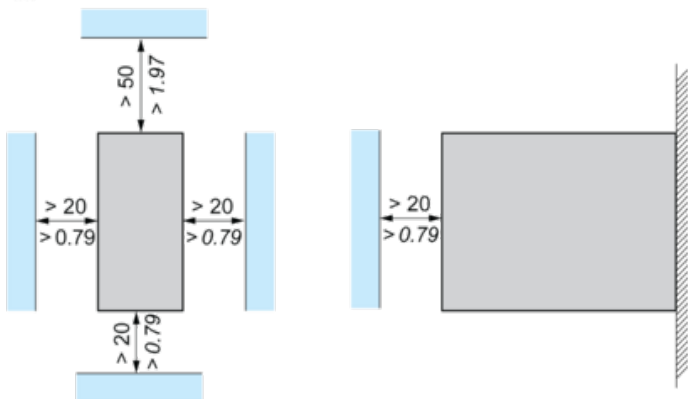



Performance Curves

Mounting Position A, B, F and G

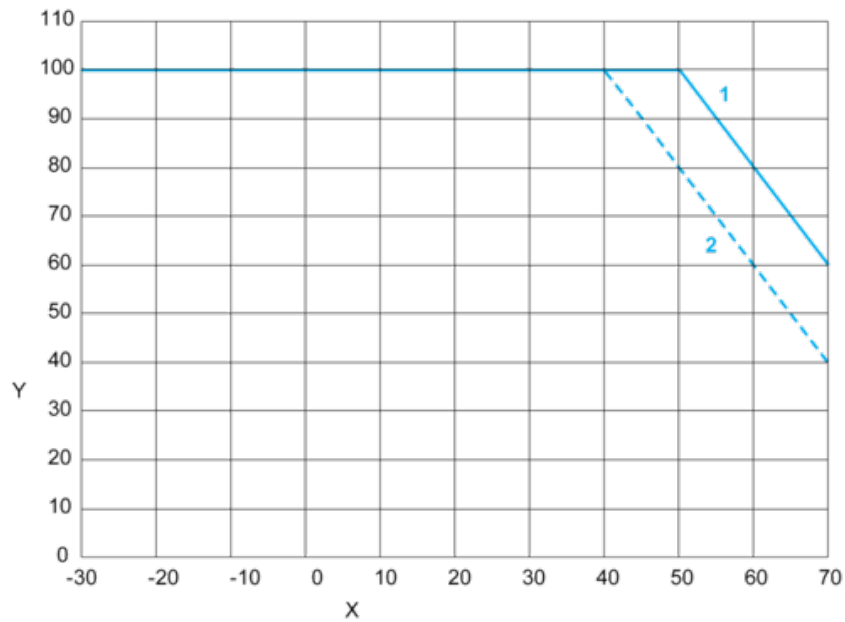

Mounting Position C

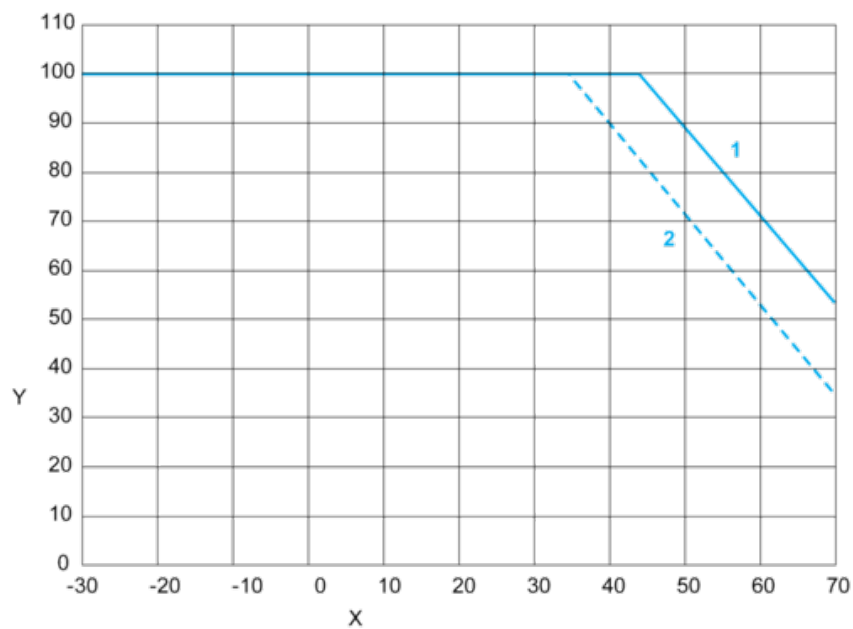

## Mounting Position H

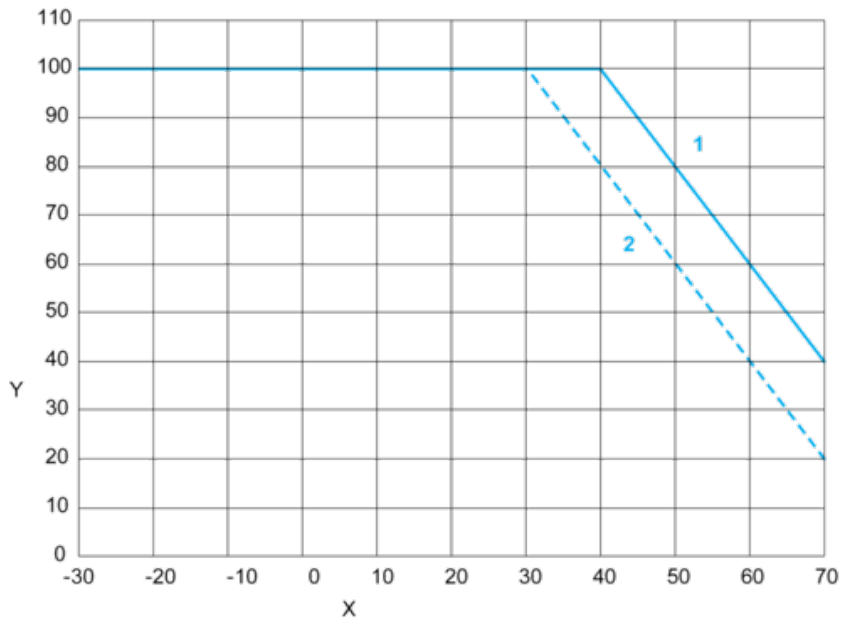

X : Surrounding Air Temperature (°C)

Y : Percentage of Max Load (%)

1 : Altitude 2000 m

2 : Altitude 5000 m

Note : < 115 VAC additional derating by 0.6% / V