

# Datasheet

## Rack Case, 4U

RS Stock number 143-9718

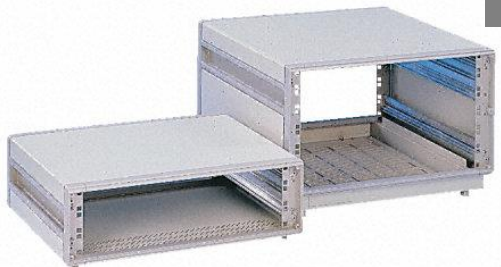

A superb range of robust cases for direct mounting of 42HP or 84HP subracks and 10½" or 19" chassis to IEC 297-1 and DIN 41494.

### Features

- Supplied assembled
- Superb modern styling
- Robust metal construction
- Conforms to IEC 297-1 and DIN 41494
- Quick release top and bottom covers
- Horizontal, vertical tower and plinth versions available.
- Front trims conceal 19" fixings
- Very large range of standard ex-stock sizes
- Easy customisation
- Painted in modern colour combination of light and mid grey to BS4800-00A01 and BS4800-00A05

### APPLICATIONS

The DIPLOMAT 19" and 10½" cases are designed to provide stylish, robust, yet economical solutions for housing electronic systems.

The standard cases are ideal for 10½" or 19" (42HP or 84HP) equipment used in either office or industrial applications. Vertical tower versions are designed as floor standing units suitable for convenient positioning either under or next to a desk.

### Items to be ordered as accessories

Description	Page
Transparent doors	10
Heavy duty carry handles	10
Feature front panels	11
19" and 10½" front panels	11
Front bezel trims	11
Rear panels	12
Fan accessories	12
Cable tidy	12
Bump down foot	13
Rear bezel trims	13
Earth continuity kit	14
Chassis supports	14
Chassis trays	14

### WOULD YOU LIKE THEM ADDED TO THE BASIC UNIT?

We can add your accessories to the DIPLOMAT case and despatch as one unit. Please refer to the DIPLOMAT Case Configurator on page 15 or contact our Sales Office on 01489 774500 for details.

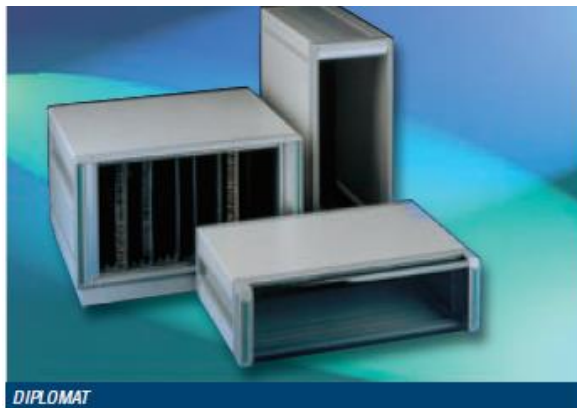

DIPLOMAT

- 1 Front trims (order as accessories)
- 2 Tilt up feet
- 3 Ventilation plinth
- 4 Side infill panel
- 5 Side handle extrusion
- 6 Top cover
- 7 Front/rear bezel assemblies
- 8 Side extrusion (4U, 6U & 9U)

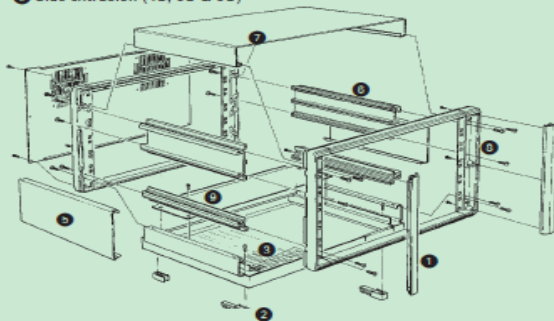

Recess trim

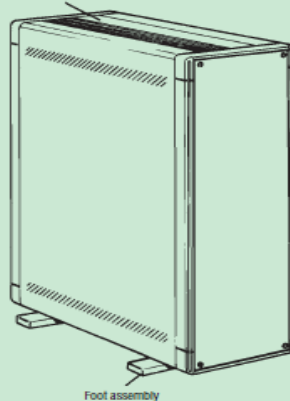

Foot assembly

**HORIZONTAL CASES WITH OR WITHOUT PLINTH**

The standard horizontal DIPLOMAT cases are available in four heights, two widths and four depths, and are supplied ready assembled.

**Contents of kit**

Description	Qty	Material/Finish
Top cover	1	0.9mm Zintec coated steel
Bottom cover (or plinth)	1	0.9mm Zintec coated steel
Handle extrusion	2	Aluminium alloy extrusion
Side extrusions (4U only)	4	Aluminium alloy extrusion
Bezels	2	Aluminium alloy castings
Feet (2 tilting)	4	ABS plastic
Finish		Textured electrostatic epoxy paint
Colour: Top/bottom covers, plinths		Light grey BS4800-00A01
Front and rear bezels,		Mid grey BS4800-00A05
side handles and 4U side extrusions		

**Order separately**

Description	Page
Transparent doors and heavy duty carry handle	10
Front panels and front bezel trims	11
Rear panels, cable tidy and fan accessories	12
Rear bump down feet and rear bezel trims	13
Earth continuity kits, chassis supports and chassis trays	14

**STANDARD 19" CASES – Supplied assembled**
**Ordering information**

Height (mm)	Width	Ext depth	Dimensions			Order code	
			Max int depth	A	B		C
3U (161,85)	19"	322	277	450	134,85	17	760-236562
		422	377	450	134,85	17	760-236563
		522	477	450	134,85	17	760-236564
4U (206,30)	19"	322	277	450	179,30	17	760-236565
		422	377	450	179,30	17	760-236566
		522	477	450	179,30	17	760-236567

**19" VENTILATION PLINTH DIPLOMATS – Supplied assembled**

(with air filtration built in as standard)

**Ordering information**

Height (mm)	Width	Ext depth	Max int depth	Dimensions					Order code
				A	B	C	D	E	
3U (161,85)	19"	322	277	450	134,85	39,5	506,4	287	760-236579
		422	377	450	134,85	39,5	506,4	387	760-236580
		522	477	450	134,85	39,5	506,4	487	760-236581
4U (206,30)	19"	322	277	450	179,30	39,5	506,4	287	760-236582
		422	377	450	179,30	39,5	506,4	387	760-236583
		522	477	450	179,30	39,5	506,4	487	760-236584

**10 1/2" HALF WIDTH CASES**
**Ordering information**

Height (mm)	Width	Ext depth	Max int depth	Dimensions			Order code
				A	B	C	
3U (161,85)	10.5"	322	277	234	134,85	17	760-236575
		422	377	234	134,85	17	760-236576
4U (206,30)	10.5"	322	277	234	179,30	17	760-236577
		422	377	234	179,30	17	760-236578

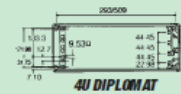
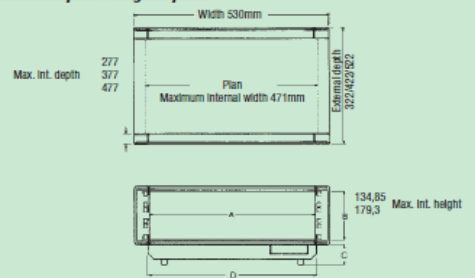
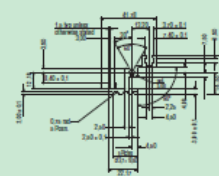
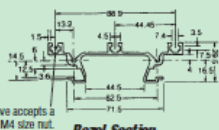
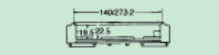
**DIPLOMAT 19" Cases 3U and 4U horizontal versions**
**3U and 4U Horizontal Versions  
Ventilation plinth and gland plates**

**3U DIPLOMAT  
4U Side Extrusion**

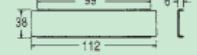
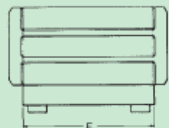
**Handle Extrusion**

**Bezel Section**

Note: Groove accepts a STD M4 size nut.

**Gland Plates  
Plinth version only**

**Ventilation Plinth**

The vertical DIPLOMAT cases offer a stylish packaging solution for office based computer systems located either on or under the operators desk. For desk cases rubber inserts are provided to prevent the unit slipping on the desk surface.

**Contents of kit**

Description	Qty	Material/Finish
Handle	1	Aluminium alloy extrusion
Vertical feet assemblies	2	ABS plastic/aluminium extrusion
Ventilated side covers	2	0.9mm Zinlec coated steel
Handle extrusions	2	Aluminium alloy extrusion
Side extrusions (4U)	4	Aluminium alloy extrusion
Handle infill	1	0.9mm Zinlec coated steel
Bezels	2	Aluminium alloy castings
Finish		Textured electrostatic epoxy paint
Colour: Side covers		Light grey BS4800-00A01
Front and rear bezels, side handles and extrusions, infills and feet		Mid grey BS4800-00A05

**Order separately**

Description	Page
Transparent doors and heavy duty carry handle	10
Front panels and front bezel trims	11
Rear panels, cable tidy and fan accessories	12
Rear bump down feet and rear bezel trims	13
Earth continuity kits, chassis supports and chassis trays	14

**VERTICAL 19" CASES – Supplied assembled**

**Ordering information**

Height (mm)	Width depth	Dimensions				Order code
		Ext depth	Max int	A	B	
3U (161,85)	19"	422	377	450	134,85	760-236635
		522	477	450	134,85	760-236636
4U (206,30)	19"	422	377	450	179,30	760-236637
		522	477	450	179,30	760-236638

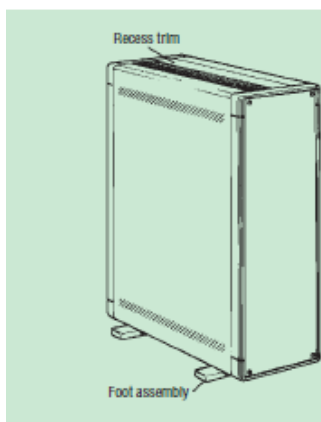

DIPLOMAT 19" Cases 3U and 4U vertical versions

**3U and 4U Vertical Cases**

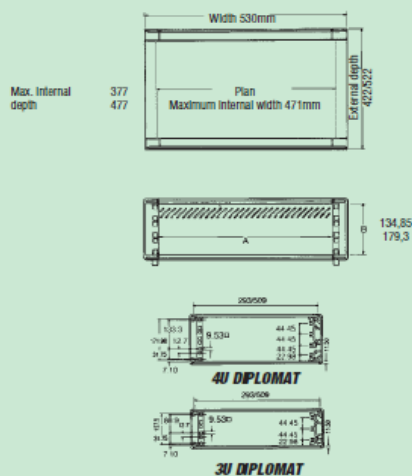

**4U Side Extrusion**

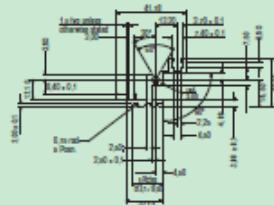

**Handle Extrusion**

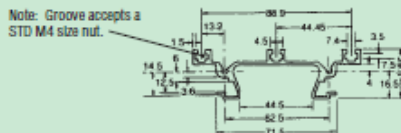

**Bezel Section**

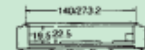

6U and 9U horizontal cases are available in either standard or plinth versions. Typical cooling performance characteristics for a loaded case can be found on page 4, which also demonstrates the likely air flow path in this scenario.

**Contents of kit**

Description	Qty	Material/Finish
Top cover	1	0.9mm Zintec coated steel
Bottom cover (or plinth)	1	0.9mm Zintec coated steel
Handle extrusions	2	Aluminium alloy extrusion
Side extrusions	2	Aluminium alloy extrusion
Bezels	2	Aluminium alloy casting
Side infills	2	0.9mm Zintec covers, coated steel
Feet (2 tilting)	4	ABS Plastic
Finish		Textured electrostatic epoxy paint
Colour: Top/bottom covers, plinths and side infills		Light grey BS4800-00A01
Front and rear bezels, side handles and side extrusions		Mid grey BS4800-00A05

**Order separately**

Description	Page
Transparent doors and heavy duty carry handle	10
Front panels and front bezel trims	11
Rear panels, cable tidy and fan accessories	12
Rear bump down feet and rear bezel trims	13
Earth continuity kits, chassis supports and chassis trays	14

**STANDARD 19" DIPLOMAT CASES – Supplied assembled**

**Ordering information**

Height	Width	Dimensions					Order code
		Ext depth	Max int depth	A	B	C	
6U	19"	322	277	450	268,20	17	760-236568
		422	377	450	268,20	17	760-236569
		522	477	450	268,20	17	760-236570
		622	577	450	268,20	17	760-236573
9U	19"	422	377	450	401,55	17	760-236571
		622	577	450	401,55	17	760-236574

**19" VENTILATION PLINTH DIPLOMATS – Supplied assembled**

(with air filtration built in as standard)

**Ordering information**

Height (mm)	Width	Dimensions							Order code
		Ext depth	Max int depth	A	B	C	D	E	
6U (295,20)	19"	322	277	450	268,20	39.5	506.4	308	760-236585
		422	377	450	268,20	39.5	506.4	408	760-236586
		522	477	450	268,20	39.5	506.4	508	760-236587
		622	577	450	268,20	39.5	506.4	608	760-236590
9U (428,55)	19"	422	377	450	401,55	39.5	506.4	408	760-236588
		622	577	450	401,55	39.5	506.4	508	760-236589
		622	577	450	401,55	39.5	506.4	608	760-236591

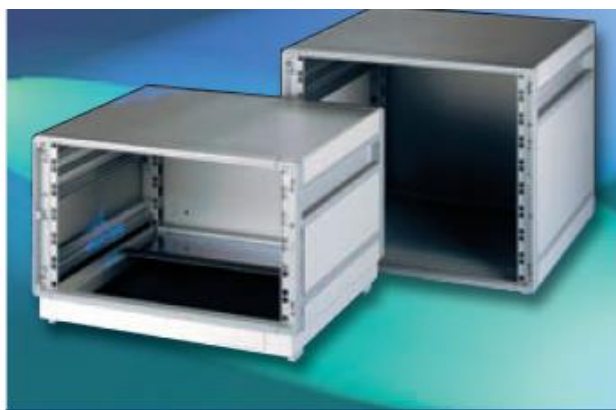

DIPLOMAT 19" Cases 6U and 9U horizontal versions

