



ES 10
ES 12
ES 15

Electric Stacker 1.0/1.2/1.5T

■ Cross series means good performance. Long time working period.

**Electric
Stacker**

REDDOT EQUIPMENT LIMITED
www.reddotequipment.com



Electric Stacker 1.0/1.2/1.5T

ES10/ES12/ES15

Distinguishing Mark						
Manufacturer			REDDOT			
Model			ES10		ES12	ES15
Driving Type			electric		electric	electric
Operating Type			pedestrian		pedestrian	pedestrian
Rated Capacity		kg	1000		1200	1500
Load Center		mm	600		600	600
Wheelbase		mm	1245		1255	1275
Weight						
Service Weight(Without Battery) ①		kg	520		580	540
Service Weight(With Battery) ②		kg	570		630	590
Tyres,Chassis						
Wheel Material			PU		PU	PU
Tyre size, Loading wheels		mm	Ø80		Ø80	Ø80
Tyre size, Driving wheels		mm	Ø210		Ø210	Ø210
Tyre size, Caster wheels		mm	Ø124		Ø124	Ø124
Number of wheels		psc	4		6	6
Dimensions						
Height, mast lowered ③		mm	2035		1985	1985
Height, mast extended ④		mm	3500		3550	3450
Lift height ⑤		mm	3000		3000	3000
Overall length		mm	1770		1770	1775
Fork width		mm	160		160	160
Overall width		mm	820		820	820
Fork Length		mm	1150		1150	1150
Outside width of forks		mm	560/680		560/680	560/680
Fork lowest height		mm	90		90	90
Ground clearance		mm	30		30	30
Turning radius		mm	1460		1460	1460
Chassis height		mm	760		760	760
Aisle width for pallets 800*1200 lengthways		mm	2220		2240	2240
Aisle width for pallets 1000*1200 crossways		mm	2300		2320	2320
Performance						
Travel speed, laden/unladen		km/h	4.5/4.7		4.5/4.7	4.5/4.7
Lifting speed, laden/unladen		mm/s	100/112		75/90	75/90
Lowering speed, laden/unladen		mm/s	92/85		85/75	85/75
Max. gradeability, laden/unladen		%	5/7		5/7	5/7
Electric-engine						
Driving motor rating S2 60 min		kW	0.75		0.75	0.75
Lifting motor rating S3 7.5%		kW	1.5		2.2	2.2
Battery voltage/nominal capacity K20		V/Ah	(12V/75Ah)×2		(12V/75Ah)×2	(12V/75Ah)×2
Battery dimension (L*W*H)		mm	(260×172×214)×2		(260×172×214)×2	(260×172×214)×2
Brake			Electromagnetic Brake			
Type of drive control			Curtis 1212P-2501			

1.The parameters in the table are of the standard model.For more information,please contact us.
2.The parameters are subject to change without notice.

ES10/ES12/ES15

Product Show

ES10
ES12
ES15

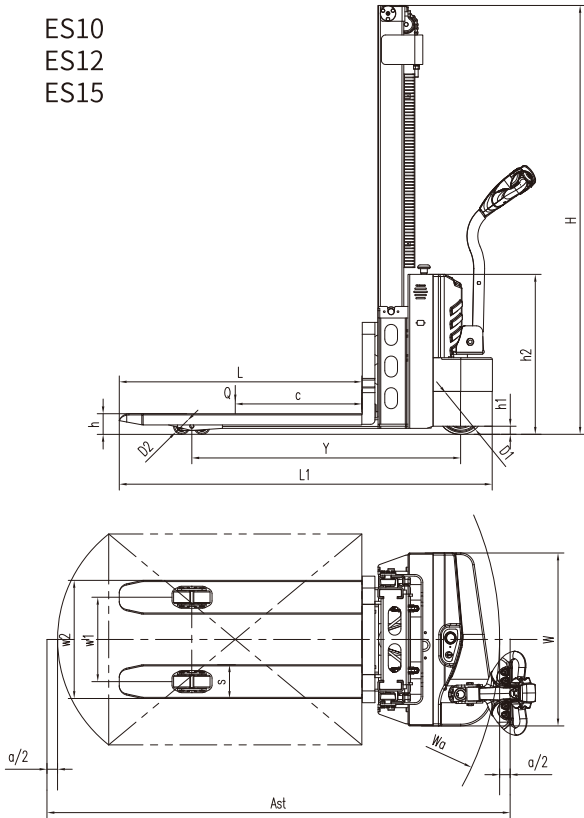

ES10/ES12/ES15

Mast Option

ES10/ES12

Lift Height h3(mm) ^⑤	Mast type	Free lift h2(mm)	Lowered Mast Height h1(mm) ^③	Extended Mast Height h4(mm) ^④
ES10/ES12				
1600	1W	--	2065/2065	2065/2065
2500		--	1785/1735	3000/3150
3000		--	2035/1985	3500/3550
3300	2W	--	2185/2135	3800/3750
3500		--	2235/2235	3950/3950
4000		--	2485/2485	4450/4350
2000		1050	1485	2445
2500		1300	1735	2945
3000		1550	1985	3445
3300	2F	1700	2135	3745
3500		1800	2235	3945
4000		2050	2485	4445

ES15

Lift Height h3(mm) ^⑤	Mast type	Free lift h2(mm)	Lowered Mast Height h1(mm) ^③	Extended Mast Height h4(mm) ^④
ES15				
1600	1W	--	1985	2065
2500		--	1735	2950
3000		--	1985	3450
3300	2W	--	2135	3750
3500		--	2235	3950
4000		--	2485	4350
2000		1050	1485	2445
2500		1300	1735	2945
3000		1550	1985	3445
3300	2F	1700	2135	3745
3500		1800	2235	3945
4000		2050	2485	4445

1.For special customization requirements, please contact us
2.The parameters are subject to change without notice.

